

EMCÉ

WINCHES

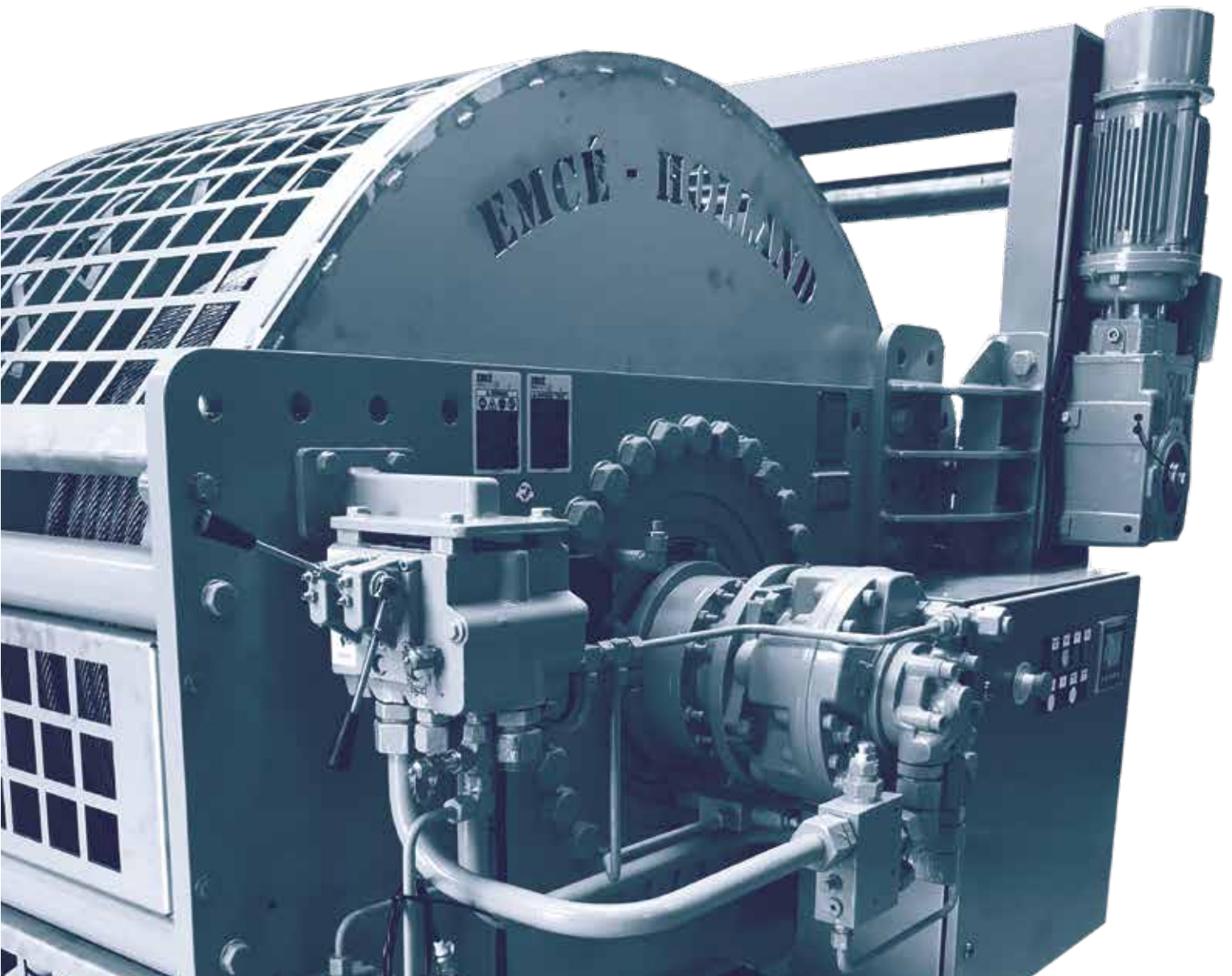

Every winch a winner

Industry

Oil & Gas

Renewables

Marine

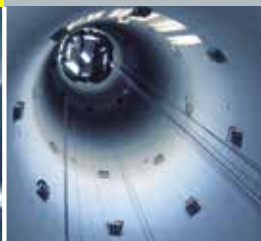

MACHINEFABRIEK EMCÉ B.V.

The technical data pages contains information regarding dimensions, performance, weighs, etc. Since the products are for 85% custom-built, the data should be used for guidance only. Definite data can be obtained from our sales office. EMCÉ are constantly striving to increase and further improve the product range. Whilst every effort has been made to ensure the accuracy of the dimensions and specifications included at the time of printing, we are unable to warrant the accuracy of the information. The inclusion of any product does not guarantee the availability of that product in the future. Customers should check both availability and conformance of the product to any critical parameters at the time of ordering.

All rights reserved. Printed in the Netherlands.

Winch catalogue table of contents

General

Company profile	5
EMCÉ advantages	6
Product range	7
Applications/Markets/Customers	8
Winch terminology and components	9
Winch options	11

Winch program data sheets

Industry	MCW series	Electric wormgear winches	14
	MC AK series	Electric wormgear winches	16
	M series	Manually operated winches	17
	EN series	Electric wormgear lifting winches	18
	H series	Hydraulic wormgear winches	20
	LV series	Pneumatic wormgear winches	22
	MR series	Personnel lifting winches	24
	SC series	Planetary compact build winches	26
	SB series	Planetary standard build winches	28
	FD series	Planetary crane winches	32
	SH series	Standard hydraulic planetary crane winches	34
	A series	General purpose winches	36
	SR series	Standard build slew ring winches	38
	TR series	Traction winches	39
Oil & Gas	OAW/OMR series	Oil & Gas air winches	42
	OHW/OHR series	Oil & Gas hydraulic winches	44
	MR FL series	Manriding winches	46
	A/F series	General purpose pneumatic winches	48
	SRM series	Mooring winches	50
Renewables			
	SC Cable Pull In winches	Winches for Renewable power sources	54
Marine	AW/PW series	Accommodation and pilot ladder winches	58
	C series	Capstans	60
	W/P/PW series	Windlasses	62
	DLR-1250	Diver launch and recovery unit	64
	HR/UW/TW series	Hose reels / umbilical - and transponder winches	65

Usefull information

Making enquiries or ordering a winch	66
Sales & service network	70
Terms and conditions	70
Overview of the Stokvis Group	71



Company profile

HISTORY

The history of EMCÉ starts in the nineteen thirties in the Brabant province of the Netherlands. In 1933 a machine workshop was started in the village of Sprang-Capelle that also gave its name to the new company, Eerste Machine Fabriek Capelle (First Machine Factory Capelle). Very soon bigger premises were needed, and the company moved to the neighbouring town of Waalwijk. The company has been acquired by the Stokvis Group in 1983 and relocated to Voorhout in order to take full advantage of the potential group synergy. Under the wings of the Stokvis Group gradual growth in turnover, staff and premises was possible in the following years. The premises now cover over 6500 sqm of workshops, offices, and workshops with room for further expansion in the future.

PROFILE

Not only the company grew, also its products increased in dimension and complexity. As a direct result of entering the corresponding, more demanding markets and the overall increasing call for certification and project management the company raised their level of certification by obtaining the ISO 9001 (currently 9001:2015), ISO 3834-2(welding) and Lloyds 3.1 material Re-marking certification. In correspondence the number of staff members involved with "paperwork" such a design appraisals, product data sheets, project coordination, quality assurance and documentation has increased since. This enables EMCÉ to confidently offer customers at the top end of the market the equipment, documentation, certification and support they require and demand. Our 85 year history in metalworking and over half a century experience in building winches enables us to offer advanced technical solutions to our customers that are not readily available on the market.

The close cooperation within the Stokvis Group yields advanced and custom gearboxes, motors and control systems were needed, but also provides advantages of scale for larger series.

And in case you might wonder... yes, not forgetting our roots we still take pride in providing simple small and effective winches for those customers or applications that require them.

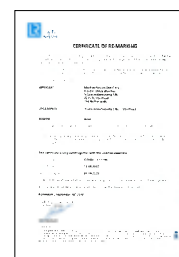

CERTIFICATION

EMCÉ is an ISO 9001-2015 and ISO 3834-2 certified company, and holds a Lloyds 3.1 Re-marking certificate.



EMCÉ advantages

EMCÉ provides high quality winches, capstans and hoisting equipment, together with services ranging from professional advice and design; through procurement, engineering and manufacture; to testing, delivery, installation and IRM.

Our mission is to exceed the quality, performance, durability and safety expectations of our customers, whether in shipbuilding, oil and gas, dredging, fishing, construction, mining, theatre or general industry.

We have identified ten key benefits to using EMCÉ:

1. **Quality**

We never compromise on quality, which underpins every element of our procurement and manufacturing process, workforce ethic, safety culture and customer service.

2. **Standards**

High standards govern the design and fabrication of every EMCÉ product, each which is certified and documented according to industry regulations, including Lloyds, DNV and ABS.

3. **Expertise**

Our 50 years of dedicated winch design and fabrication experience translates into genuine knowledge and understanding.

4. **Innovation**

We have pioneered winch design and construction based on simplicity, efficiency and reliability, creating low maintenance products that operate trouble-free for longer.

5. **Flexibility**

We create winches and capstans ranging from 100 kg to 100 tons with electric, hydraulic and pneumatic options and gear configurations to suit countless applications.

6. **Bespoke Solutions**

Our products are designed to meet your specific operating and performance conditions. Around three-quarters of our products are tailor-made.

7. **In-house Capability**

At EMCÉ, it's all under one roof - from the drawing office and administration, to the engineering

and testing bays. This gives us complete control of the quality and availability of resources, as well as the production process as a whole.

8. **Rapid Response**

EMCÉ responds quickly to new orders with rapid turnarounds even on complex projects. Naturally, our off-the-shelf catalogue offers even more immediate solutions on a daily basis.

9. **Location**

Headquartered close to Schiphol Airport and the port of Amsterdam, EMCÉ products are swiftly dispatched to all four corners of the world. Our international network of suppliers and service experts provides global support.

10. **Price**

Unit price is obviously important, but so too is reliability and the cost of maintenance. When it comes to product efficiency and the 'total cost of ownership', EMCÉ products leave others standing.



Product range

WINCHES

Our winches provide solutions for lifting, pulling, man-riding, mooring and anchoring. They range from 100 kg to 100 tons and are electrically, hydraulically or pneumatically driven - or equipped with a combination of these options. Alongside a comprehensive range of standard worm gear- and planetary-driven winches, we offer tailored solutions to suit any performance criteria and application. We also provide a complete design appraisal service and F.A.T.s for third parties, using our unique dynamic in-house test bed which is rated to 85 tons.

CAPSTANS

We provide rugged, self-contained worm gear or planetary capstan systems with electric, hydraulic or pneumatic transmission. The standard range runs to 15 tons and/or working head diameters up to 600mm and all capstans can be ATEX-rated, where required. The on-deck drive of worm gear capstans is equipped with a waterproof motor for intermittent

use, whilst the below-deck drive has a drip-waterproof motor, and a self-aligning mounting plate suitable for high static loads, such as those applied to mooring ropes.

Our planetary capstans feature a cast-iron capstan-head mounted onto a heavy-duty planetary gearbox. The whole drive is housed in a watertight tubular frame to provide optimal protection from the elements.

HOSE REELS

EMCÉ's hose reels - which range from 1 to 8 inches in diameter and up to 4 metres flange size - have applications both on and offshore, but are principally installed on heavy lift vessels, semi-sub, DSVs, research vessels, cable and pipe laying vessels and offshore pile-driving barges. They are usually built to order and spool hoses for fresh water, MDO fuel and hydraulic fluids, pneumatic hoses and electrical power supply cables. Our reels can be electrically, hydraulically or pneumatically driven and ATEX rated, where applicable.

PROJECTS

Over the last 50 years, EMCÉ has delivered more than 30,000 winches worldwide. But EMCÉ has also developed some of its products beyond the winch stage, for example in the creation of its proprietary Diving Launch and Recovery System - the DLR 1250 - which is used for offshore diving applications to 90 meters. Fully compliant with the requirements of EC Machinery Directives, IMCA regulations and with an ATEX certificate, the DLR-1250 is available for sale or lease.

SERVICE & REPAIR

Although we design and supply the highest quality products, regular maintenance can be critical to ensuring optimal performance, safety and regulatory compliance. Since nobody knows EMCÉ's winches better than EMCÉ itself, our specialist teams of trained experts are the best people to conduct in-house and on-site inspection, repair and maintenance work. Our supplier network also stocks the full complement of replacement parts for rapid repair, when required.



Applications/Markets/Customers

INSHORE APPLICATIONS

Theatres
 Construction
 Warehouses
 Overhead cranes
 Shipyards (slipways / shiplifts)
 Power / nuclear plants
 Mining industry
 Container cranes
 Research institutions
 Windmills
 High cranes / structures (manriding)
 Ferris wheels
 Factories
 Land rigs
 Steel industry
 Railways
 Hydro/electric plants
 Tunneling systems
 General industry
 Petrochemical Oil & Gas landrigs

MARINE & OFFSHORE APPLICATIONS

Anchor treatment vessels
 Ferries
 Dredgers
 Crane vessels
 River vessels
 Passenger ships
 Buoy positioning barges
 Coastguard vessels
 Minesweepers (stainless steel winches)
 Stealth corvettes (stainless steel winches)
 Tugs
 Off shore platforms
 Split barges
 Coasters
 Tankers
 Fishing vessels
 Inland vessels (car cranes)

A FEW OF OUR CUSTOMERS*

Acergy, Agip, Aramco, Awilco, Airbus Ind., Allseas, ALE Heavylift, APL, Arab Contractors, Bauer Maschinen, Bharat India, Bluewater, Bentec, BNFL BHEL, Bofors, Bomco, Bosch-Rexroth, BSR Group, Certex, Claxton Int., CNOOC, Conoco Phillips, CSO, Daewoo Heavy Ind., Damen, DePret, Dolphin, Doppelmayer, Dubai Drydocks, Fugro, Flexifrance, Grandweld, IHC-Dredgers, Imodco, Heerema, Huisman, Herrnknecht, Itag, Jurong Shipyard, Kobelco Japan, Keppel Fels, Keppel-Verolme, KCA Deutag, Lamprell, Maersk, Mammoet, McDermott, M.I.S., Modec, Monobuoy, National Oilwell, Noordhoek, Norsk Hydro, NOV, N.D.C., O.N.G.C., Pakistan Navy, Pohang Steel Korea, PPL Shipyard, Pride Int., Rolls-Royce, Saipem, Samsung, SBM Offshore, Seadrill, Shell, Statkraft, Statoil, Stena, Stolt Offshore, SeaTrucks, Subsea7, Smedvig, SOFEC, Swedish Coast Guard, SWS, Timsah, Technip, Transocean, Total Elf Fina, Unocal, Vantage, Vopak

* An updated reference list > www.emce.nl/customers



Winch terminology and components

INTRODUCTION

With numerous possible configurations of winch, we thought a brief overview of their parameters, standards and selection criteria would prove useful.

WORKING LOAD LIMIT (WLL)

WLL usually applies to the first layer of cable and decreases with each additional cable layer. The line pull is expressed in kg or daN. It is important that the working length of the cable on the drum is determined, with three additional 'safety windings' remaining on the drum at all times.

CABLE SAFETY FACTOR

Depending on the classification group of the mechanism, the exact rope safety factor (breaking strength) for lifting winches can be chosen according to ISO 4308-1. A five-fold factor is normally applied to lifting applications; three-fold for pulling winches and an eight to ten-fold factor for personnel lifting.

SPEED

The required speed of winches varies according to their purpose. In some cases, a variable speed option is required, delivered via a proportional control valve for pneumatic or hydraulic winches. For electric winches, frequency inverters are a cost-effective solution with additional technical benefits.

POWER SOURCE

EMCÉ products accommodate a range of power supply options, including electric, hydraulic and pneumatic. Should your power source be other than the one stated in this catalogue, please consult EMCÉ and our Engineering Department will recalculate the winch based on your available supply.

OPERATING ENVIRONMENT

Our winches are built to withstand a variety of challenging environmental conditions, including standard operating temperatures of 0° - 40° C. However, where more exacting conditions apply, we can build mechanisms that extend these operating parameters to suit.

BRAKES

Every lifting winch requires a fail-safe braking system. Our standard electric and pneumatic worm gear winches are self-braking, which is fine for general lifting purposes. Brake motors can also be incorporated where necessary, or we can provide mechanisms without brakes.

CONTROLS

All available winch-related controls can be incorporated into EMCÉ's products. On electric motors, a range of additional controls are available alongside the normal push buttons, direct reversing switches and remote controls (pendant or radio-controlled). These include limit switches (to stop the winch when the drum is full or empty), an electronic line pull limiter, variable speed, slack and rope detection and constant tensioning, Exd executions etc.



Winch terminology and components

CLUTCHES

We generally use either friction or claw-type clutches, dependent on the requirement. Friction clutches can be operated under load, can compensate for differences in turning speeds between the drum and driveline and can be operated either manually or remotely. As such, they tend to be more complex and expensive than claw-type clutches which, by contrast, are simpler, more robust, dependable and inexpensive.

BAND BRAKES

Bank brakes are typically used for applications where a second brake is required, such as manriding or where the static load is a multiple of the dynamic WLL. They can be provided manually or fail-safe automatically by means of a hydraulic or pneumatic cylinder.

ELECTRIC REQUIREMENTS

Ordinarily, we work with protection class IP 54 (splash watertight and dust-proof) for motors and control boxes. Pendant remote controls are IP 65 protected. Motors can also be supplied with IP 56 TENV (totally enclosed and non-ventilated), for deck equipment in marine use. We provide explosion-proof winches and spark-free motors and control boxes for use in designated zones.

CABLE GUIDES

The correct spooling of a cable on a winch drum depends on many factors, but is always desirable and beneficial for both cable storage and cable life. Selecting the right type of rope is important, but even more important is the correct distance between the winch drum and the

first sheave that together determine the so called fleet angle.

Correct cable spooling can be aided by means of a grooved drum (we do both spiral and Lebus grooves), a pressure roller or a swiveling sheave. However in all cases the fleet angle should not exceed a 0 to 2° angle on either side of the drum centre line, and then only with a grooved drum with a single cable layer.

For more extreme angles a driven spooling gear must be used that dynamically positions the cable on the drum in a continuous lateral movement along the drum.

The spooling gear may be driven by a chain from the drum, but independently driven spooling gears are also available from EMCÉ, which provide a high degree of accuracy even in multilayer applications with often thousands of metres of cable.



PRESSURE ROLLER



DRUM GUARD



SPINDLE LIMIT SWITCH

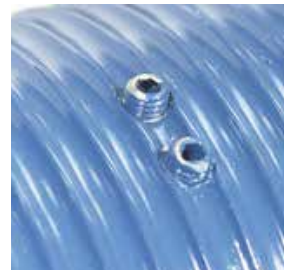

GROOVED DRUM



DRUM DIVIDER FLANGE



ENCODER + SPINDLE LIMIT SWITCH



CLAW CLUTCH

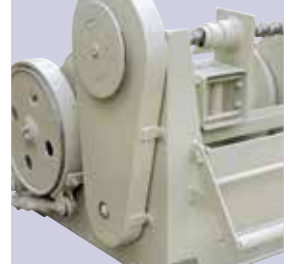

FRICTION CLUTCH

Winch options



SLACK WIRE SWITCH



PNEUMATIC SPINDLE LIMIT SWITCH

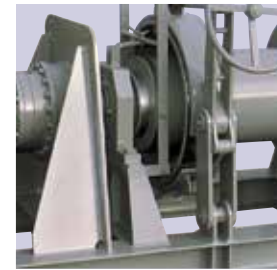

MANUAL BAND BRAKE



HYDRAULIC OPERATED BAND BRAKE



PENDANT REMOTE CONTROL



PNEUMATIC CONTROL VALVE

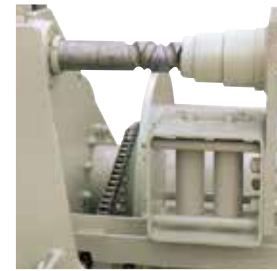

SPOOLING GEAR

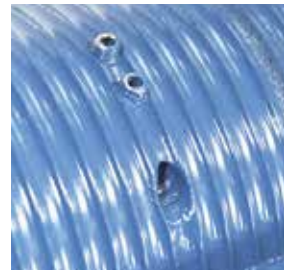

ADDITIONAL ROPE ANCHOR



SLIP RING

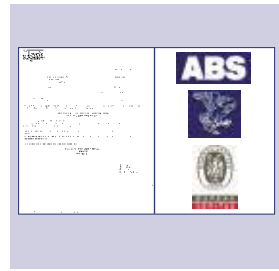

CLASSIFICATION CERTIFICATES OF LR, BV, ABS, GL, DNV, ETC.



MANUAL EMERGENCY CRANK (ON ELECTRIC MOTOR)



CONTROL PANEL WITH FREQUENCY IN INVERTER

EMCÉ
WINCHES



Industry

Oil & Gas

Renewables

Marine



A range of electric self-braking wormgear winches developed for heavy duty pulling and traversing duties up to 2,200 kg. Due to the self-braking wormgears the winches are suitable for pulling up a slope. A brake is available as an option for accurate positioning or repetitive lifting applications up to 1,700 kg.

Standard features

- Self-braking wormgear transmission
- IP 54 400 V AC / 3 phases / 50 Hz non-braked motor.
- Steel drum (not grooved) with cable fixing point at flange
- Single drum support (MCW 250, MCW 500)
- Two drum supports (all other models)
- Double layer 2-component conservation according ISO 12944 category C2-Low, colour RAL 5010
- FEM / ISO class: T2-L2-M2

Available options

- Braked motor (aluminium or cast iron)
- IP 56 TENV cast iron motor for marine applications
- 220 single-phase motors (up to MCW 750)
- 24 V DC motors
- Explosion-proof motors
- Protective steel motor cover
- Manual or remotely controlled disengaging clutch
- Band brakes
- Grooved drum

- Drum pressure roller
- Alternative speeds
- Alternative drum dimensions / split drums / additional rope anchors / etc.
- Drum guards
- Emergency cranking
- Marine / offshore coating systems

Available control options

- IP 65 direct pendant remote control with emergency stop (up to 1.5 kW 220 V AC / 1 phase or 2.2 kW 400 V AC / 3 phase)
- IP 55 Control box with push-buttons and emergency stop built acc. to NEN 1010
- IP 66 Control box with low-voltage IP 65 remote control built acc. to NEN 1010
- Load limiter
- Frequency inverter for variable speed control
- Wireless radio remote control systems
- Limit switches
- Slack wire switches

Winch type	WLL Pulling 1 st layer kg	WLL Pulling 5 th layer kg	WLL Lifting 1 st layer kg	WLL Lifting 5 th layer kg	Recomm. rope diam. mm	Speed 1 st layer m/min.	Drumcap. 1 st layer m	Drumcap. 5 th layer m	Motor power 400 V kW S2
MCW 250	250	170	200	135	6	6	2	19	0.75
MCW 500	500	340	400	275	6	6	2	19	1.1
MCW 750	750	490	600	390	7	6	6	42	1.5
MCW 1200	1200	750	960	600	8	5	5	38	2.2
MCW 1700	1700	1055	1300	805	10	6	7	50	4
MCW 2200	2200	1365	1700	1055	12	7	9	63	5.5
Winch type	WLL Pulling 1 st layer kg	WLL Pulling 5 th layer kg	WLL Lifting 1 st layer kg	WLL Lifting 5 th layer kg	Recomm. rope diam. mm	Speed 1 st layer m/min.	Drumcap. 1 st layer m	Drumcap. 5 th layer m	Motor power 230 V 1 phase kW S2
MCW 250 SPH	250	170	200	135	6	5	2	19	0.75
MCW 500 SPH	500	340	400	275	6	5	2	19	1.5
MCW 750 SPH	700	460	550	360	7	5	6	42	1.8

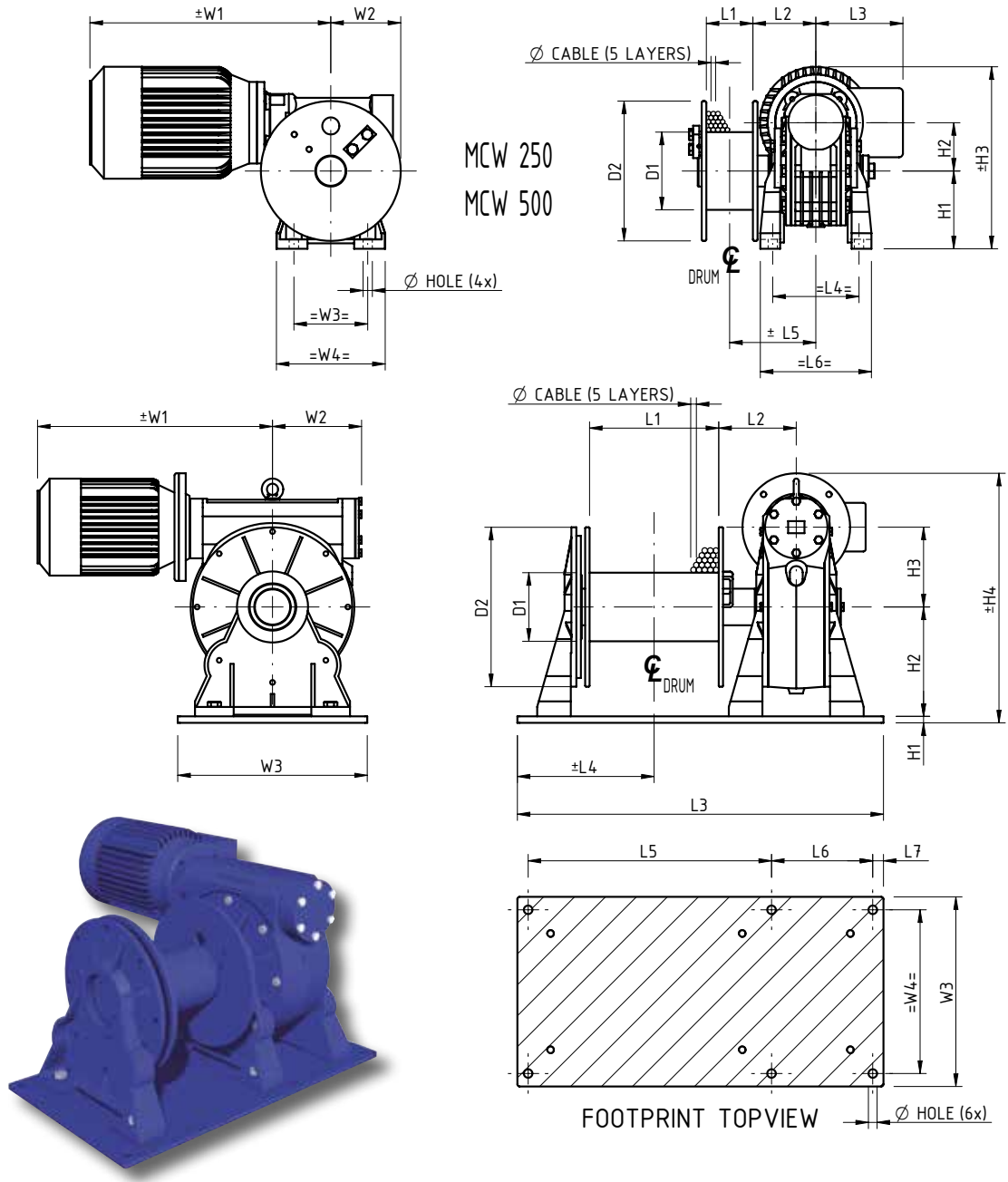

Type	Mass (kg)	D1	D2	L1	L2	L3	L4	L5	L6	L7	H1	H2	H3	H4	W1	W2	W3	W4	Hole Ø
MCW 250	20	100	180	60	81	118	111	111	143	-	100	62	233	-	310	90	95	140	11.5
MCW 500	35	100	200	60	91	129	146	121	186	-	142	87	309	-	358	110	140	220	11.5
MCW 750	55	100	200	150	104	500	187	320	150	15	10	142	87	320	358	110	270	240	13
MCW 1200	90	100	250	150	125.5	560	203	340	180	20	10	170	110	380	421	140	325	285	17
MCW 1700	140	121	280	200	146.5	640	232	415	185	20	15	195	130	443	492	154	370	320	17
MCW 2200	190	146	320	250	155	710	260	470	200	20	15	220	150	510	519	180	410	360	17

Two electric self-braking wormgear winches, specially developed for car lifting purposes. The winches can be mounted on to a davit or crane boom. Winches can be used to lift cars, Zodiacs or any other non life saving craft on board of ships.

Standard features

- Self-braking worm gear transmission
- IP 56 TENV cast iron non-braked motor 400 V AC / 3 phases / 50 Hz.
- Steel drum (not grooved) with cable fixing point at flange
- Two drum supports
- Double layer 2-component conservation according ISO 12944 category C2-Low, colour RAL 5010
- FEM / ISO class T2-L2-M2

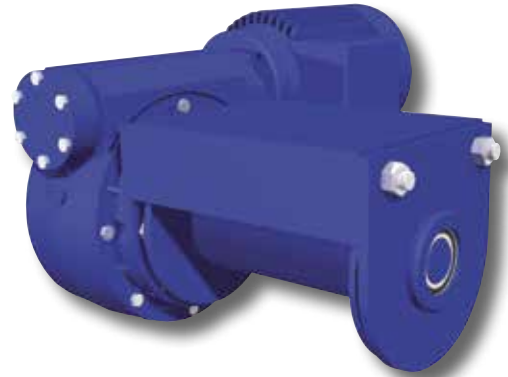

Available options

- Braked motor
- Alternative speeds
- Marine / offshore coating systems

Available control options

- IP 55 Control box with push-buttons and emergency stop built acc. to NEN 1010
- IP 55 Control box with low-voltage IP 65 remote control built acc. to NEN 1010
- Load limiter
- Frequency inverter for variable speed control
- Limit switches

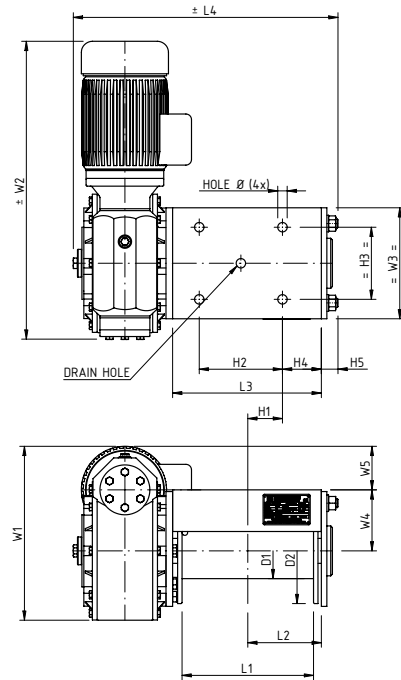

WLL	WLL 1 st layer kg	WLL 4 th layer kg	Recomm. rope diam. mm	Speed. 1 st layer m	Drumcap. 1 st layer m	Drumcap. 4 th layer m	Motor power 400 V kW	Weight without rope kg
MC 1200 AK	960	665	8	5	9	45	1.5	92
MC 1700 AK	1300	890	10	6	8	45	3	140

AK type	Mass (kg)	D1	D2	L1	L2	L3	L4	H1	H2	H3	H4	H5	W1	W2	W3	W4	W5	Hole Ø
1200	92	100	190	237	132.5	268	477	62.5	150	130	70	30	313,5	537	200	110	78.5	17
1700	140	121	240	240	134	291	540	59	170	160	75	30	400	638	240	150	105	17

A range of floor-mounted manually driven winches developed for heavy duty lifting and pulling duties up to 2,620 kg. For applications where no other power source than human power is available, for example, windlasses on small barges, lifting of ramp doors on small ferries or any other industrial heavy duty job. The customer can choose for a hand wheel or crank drive system. A special safety crank with integrated centrifugal brake is available as an option for lifting duties. The maximum human force to be applied is 25 kg.

This range of standard winches can be easily adapted to customer requirements so if your specifications differ from the standard models as stated do not hesitate to send us your inquiry. We will offer you the required model accordingly.

Standard features

- Slight self-braking worm gear transmission for M 500 up to M 1000
- High-effi performance transmission for M 1500 and M 2000
- Heavy-duty industrial construction of all parts
- Manual crank or handwheel
- Steel drum (not grooved) with cable fixing point at flange
- Two drum supports
- Double layer 2-component conservation, colour RAL 5010

Available options

- Manual safety crank(s) with centrifugal brake for lifting duties
- Manual disengaging clutch
- Manual band brake
- Grooved drum
- Drum pressure roller
- Alternative drum dimensions / split drums / additional rope anchors / etc.
- Drum guards
- Marine / offshore coating systems

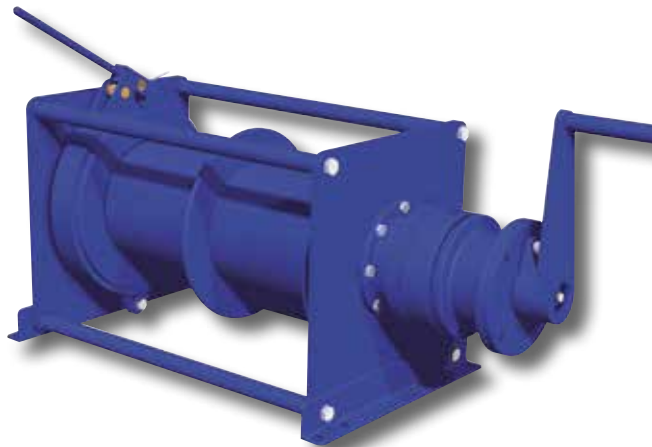

Winch Type	WLL 1 st layer kg	WLL top layer kg	Recomm. rope diam. mm	Speed@ 60 rpm top layer m/min.	Drumcap. 1 st layer m	Drumcap. top layer m	Torque required in nm	Weight without rope kg
M 500	725	500 (5)	6	2	7	47(5)	45	50
M 750	1120	750 (5)	8	1,5	7	44 (5)	55	80
M 1000	1370	1000 (4)	8	1	9	44 (4)	60	120
M 1500	2030	1500 (4)	10	1	9	46 (4)	45	160
M 2000	2620	2000 (4)	12	0,7	12	65 (4)	45	220

A range of electric self-braking wormgear winches developed in accordance to the European standards for lifting winches specially FEM 1.001 T3-L3-M4 and DIN 15020-1AM with a long life service.

The self-braking wormgear is combined with an automatic fail-safe motor brake for precise load control.

A grooved drum is fitted as standard according to the CE standard on types EN 500 to EN 1325.

A grooved drum ensures long service life for the cable.

Standard features:

- Self-braking wormgear transmission
- IP 54 aluminium braked motor 400 VAC / 3 phases / 50 Hz.
- Grooved steel drum (not grooved on EN 200, EN 450) with cable fixing point at flange
- Single drum support (EN 200, EN 450)
- Two drum supports (all other models)
- Double layer 2-component conservation according ISO 12944 category C2-Low, colour RAL 5010
- FEM / ISO class T3-L3-M4

Available options:

- IP 56 TENV cast iron motor for marine applications
- 220 V AC single-phase motors (up to EN 500)
- 24 V DC motors
- Explosion-proof motors
- Protective steel motor cover
- Drum pressure roller
- Alternative speeds
- Alternative drum dimensions / split drums / additional rope anchors / etc.
- Drum guards
- Emergency cranking
- Marine / offshore coating systems

Available control options:

- Direct pendant remote control IP 65 with emergency stop (up to 1.5 kW 220 VAC / 1 phase or 2.2 kW 400 VAC / 3 phase)
- IP 55 Control box with push-buttons and emergency stop built acc. to NEN 1010
- IP 66 Control box with low voltage IP 65 remote control built acc. to NEN 1010
- Load limiter (required by CE for applications exceeding 1000 kg WLL)
- Frequency inverter for variable speed control
- Wireless radio remote control systems
- Limit switches
- Slack wire switches



Winch type	WLL 1 st layer kg	WLL 3 rd layer kg	Recomm. rope diam. mm	Speed 1 st layer m/min.	Drumcap. 1 st layer m	Drumcap. 3 rd layer m	Motor power 400 V kW
EN 200	200	165	5	6	3	11	0.55
EN 450	450	375	6	7	3	11	1.1
EN 500	500	405	7	5.5	7	25	1.1
EN 800	800	640	8	6	6	23	1.5
EN 1050	1050	840	10	7.5	9	31	3
EN 1325	1325	1065	11	8	11	40	4

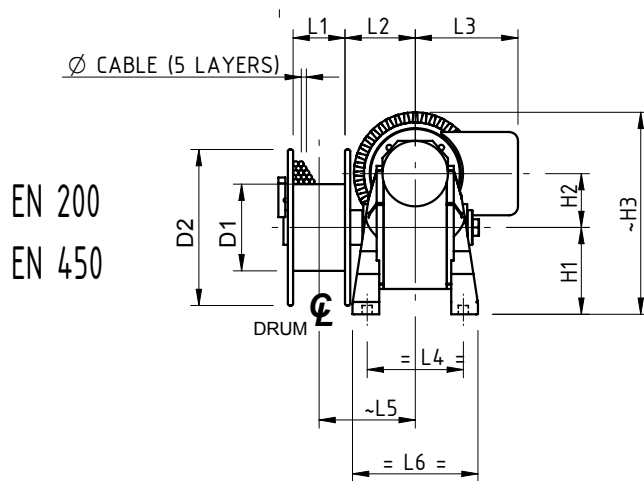
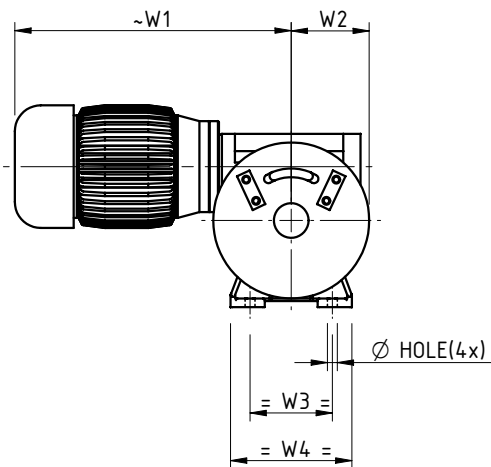

EN 200
 EN 450

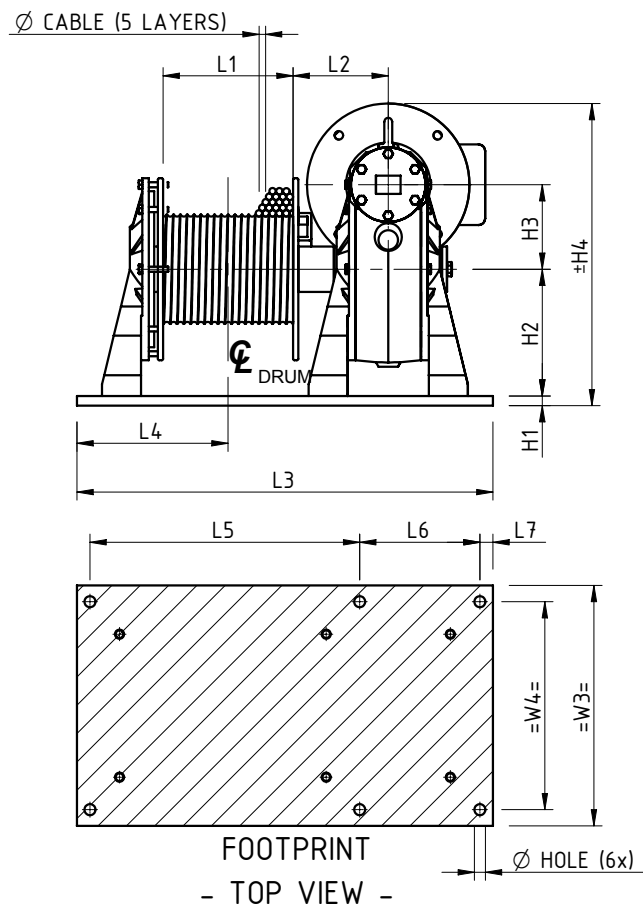
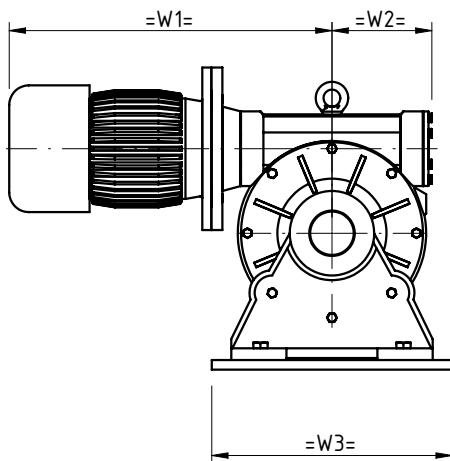

Type	Mass (kg)	D1	D2	L1	L2	L3	L4	L5	L6	L7	H1	H2	H3	H4	W1	W2	W3	W4	Hole Ø
EN 200	20	100	180	60	81	118	111	111	143	-	100	62	233	-	319	90	95	140	11.5
EN 450	35	121	200	60	91	129	146	121	186	-	142	87	309	-	374	110	140	220	11.5
EN 500	55	121	200	150	104	500	187	320	150	15	10	142	87	320	392	110	270	240	13
EN 800	90	127	250	150	125.5	560	203	340	180	20	10	170	110	380	435	140	325	285	17
EN 1050	140	159	280	200	146.5	640	232	415	185	20	15	195	130	443	496	154	370	320	17
EN 1325	190	178	320	250	155	710	260	470	200	20	15	220	150	510	525	180	410	360	17

A range of hydraulic self-braking wormgear winches developed for heavy duty lifting and pulling applications up to 2,500 kg. Due to the modular concept and the flexibility of our production it is possible to build, with short delivery times, many variations of these winches such that they may be adapted to your specific needs. The types H 500 and H 700 are constructed without a brake and are designed to be totally self-braking. The types H 1200 to H 2500 are designed with a fail-safe brake and brake valve.

Standard features:

- Wormgear transmission
- Orbitmotor
- Steel drum (not grooved) with cable fixing point at flange
- Single drum support (H 500)
- Two drum supports (all other models)
- Double layer 2-component conservation according ISO 12944 category C2-Low, colour RAL 5010
- Brake and double acting brake valve (not on H 500 and H 700)
- FEM / ISO class T3-L2-M3

Available control options:

- Proportional control valves
- Hydraulic power packs

Available options:

- Manual disengaging clutch
- Band brakes, manual or automatic fail safe
- Grooved drum
- Drum pressure roller
- Alternative speeds
- Alternative drum dimensions / split drums / additional rope anchors / etc.
- Drum guard
- Emergency cranking
- Marine / offshore coating systems



Winch type	WLL 1 st layer kg	WLL 3 rd layer kg	Recomm. Rope diam. mm	Speed 1 st layer m/min.	Drumcap. 1 st layer m	Drumcap. 3 rd layer m	Pressure drop in bar	Flow in l/min.
H 500 *	500	400	6	6.5	2	10	50	20
H 700 *	700	540	8	6.5	5	20	60	20
H 1200	1200	940	9	9	5	21	95	50
H 2000	2000	1560	12	10	8	28	105	60
H 2500	2500	1965	13	11	9	36	130	60

* All winches with brake with the exception of the H 500 and H 700

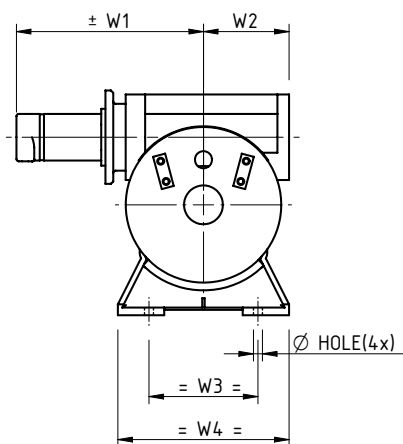

H 500

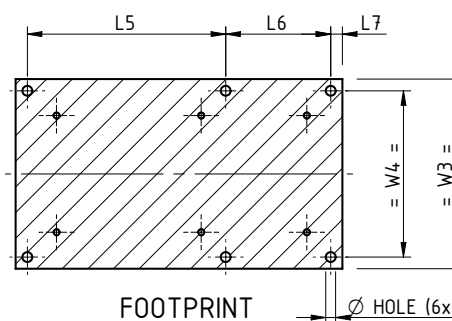
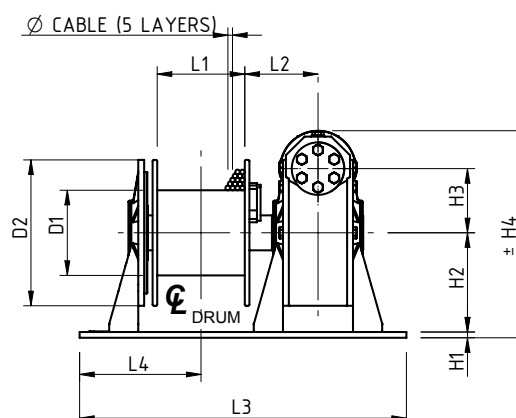
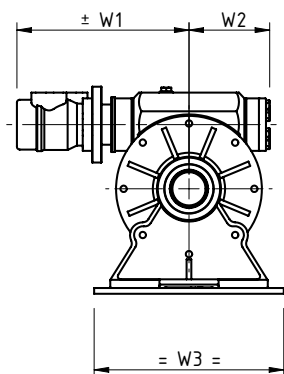
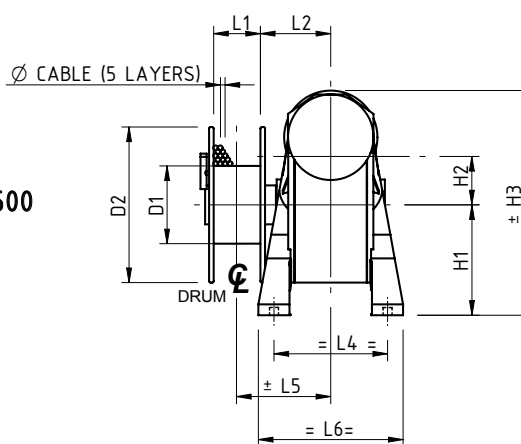

Type	Mass (kg)	D1	D2	L1	L2	L3	L4	L5	L6	L7	H1	H2	H3	H4	W1	W2	W3	W4	Hole Ø
H 500	35	100	200	60	91	-	146	121	186	-	142	87	289	-	253	110	140	220	11.5
H 700	50	100	200	150	104	500	187	320	150	15	10	142	87	309	253	110	270	240	13
H 1200	82	121	250	150	125.5	560	203	340	180	20	10	170	110	354	400	140	325	285	17
H 2000	134	159	280	200	146.5	640	232	415	185	20	15	195	130	440	456	154	370	320	17
H 2500	170	178	320	250	155	710	280	470	200	20	15	220	150	510	467	180	410	360	17

This range of explosion-proof winches provides the solution for pneumatic winch applications demanding lightweight construction. The use of vane type motors and inherently safe self-braking wormgears ensures trouble-free operation and low maintenance. These winches find their use in general industry, oil and gas exploration, and in many places where compact, explosion-proof hoisting gear is required.

The range includes two fast speed types, the LV 256 and LV 508, which also have optional carrying handles, and slower speed types up to 1700 kg of lifting capacity.

The self-braking properties of the wormgear drive combined with closed ports is sufficient for almost all hoisting purposes. An additional brake may be necessary for accurate positioning of a load. Please consult the factory in this case.

Standard features

- Self-braking wormgear transmission
- Rotary vane motor
- Steel drum (not grooved) with cable fixing point at flange
- Two drum supports
- Double layer 2-component conservation according ISO 12944 category C2-Low, colour RAL 5010
- FEM / ISO class T3-L2-M3

Available control options

- Proportional local or remote control valve
- Pneumatic limit switch
- Pneumatic slack wire switch

Available options

- Manual disengaging clutch
- Band brake, manual or automatic fail-safe
- Grooved drum
- Drum pressure roller
- Alternative speeds
- Alternative drum dimensions / split drums / additional rope anchors / etc.
- Drum guard
- Emergency cranking
- Marine / offshore coating systems

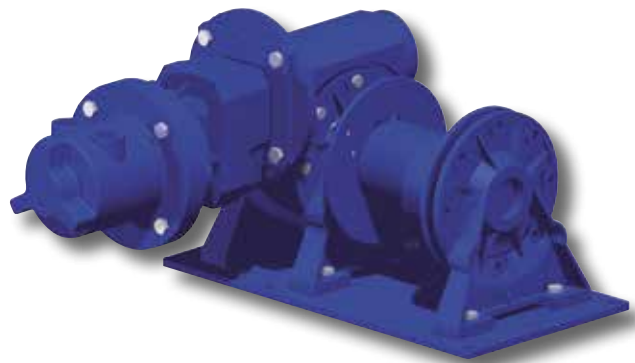

Winch Type	WLL 1 st layer kg	WLL 3 rd layer kg	Recomm. rope diam. mm	Max. speed 1 st layer m/min.	Drumcap. 1 st layer m	Drumcap. 3 rd layer m	Pressure drop in bar	Flow in l/sec.
LV 256	250	210	5	12	8	30	6,5	60
LV 508	500	400	7	12	6	22	6,5	95
LV 425	425	350	6	5	7	26	6,5	20
LV 750	750	600	8	5.5	6	23	6,5	60
LV 1250	1250	1000	10	6	9	32	6,5	95
LV 1700	1700	1325	12	7	10	35	6,5	140

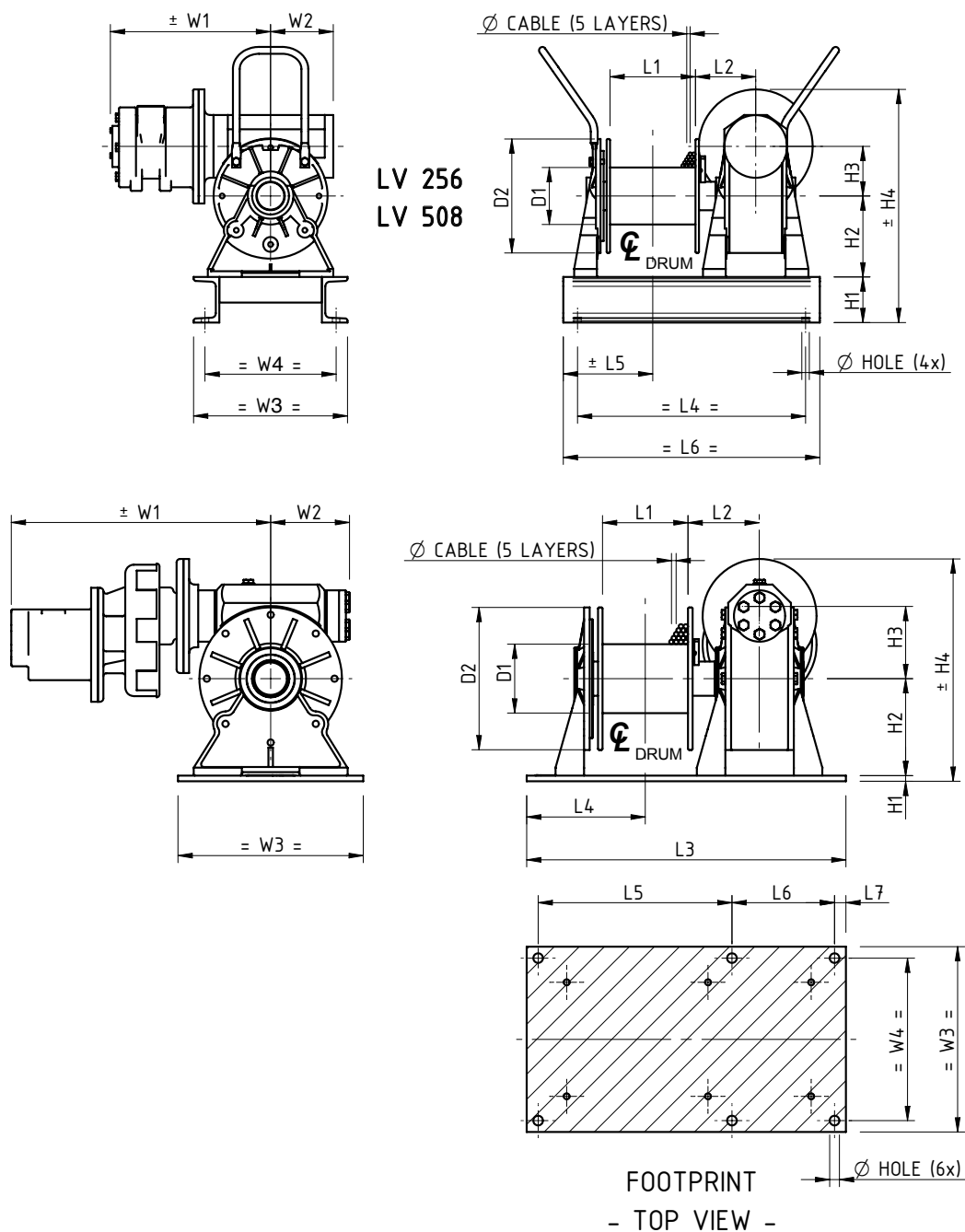

Type	Mass kg	D1	D2	L1	L2	L3	L4	L5	L6	L7	H1	H2	H3	H4	W1	W2	W3	W4	Hole Ø
LV 256	58	100	200	150	105	-	400	157	450	-	80	142	87	409	278	110	270	230	13
LV 425	59	100	200	150	105	500	187	320	150	15	10	142	87	389	374	110	270	240	13
LV 508	65	100	200	150	105	-	400	157	450	-	80	142	87	409	281	110	270	230	13
LV 750	93	121	250	150	125.5	560	203	340	180	20	10	170	110	390	455	140	325	285	17
LV 1250	149	146	280	200	146.5	640	232	415	185	20	15	195	130	440	490	154	370	320	17
LV 1700	192	159	320	250	155	710	260	470	200	20	15	220	150	510	609	180	410	360	17

Personnel lifting winches are mainly built to client specifications and can be executed with a self-braking worm-, helical- or planetary gear depending on the load required. The drive can be either electric, hydraulic or pneumatic. EMCÉ has supplied manriding systems up to a working load limit of 10,000 kg.

EMCÉ have supplied winches for the following applications:

- safety harness or a boatswain's chairs
- diving frame applications
- baskets or platforms
- cable way rescue winches

As safety is most important with personnel lifting applications a third party design review is often required. The type of design review is however very much depending on the local rules and regulations. For onshore personnel lifting applications within the European Union often a EC type examination is required. Offshore personnel lifting winches often require the same class as the ship or rig they are being used on. Most common classifications for offshore personnel lifting winches are LRS, ABS, DNV and GL.

All the above classification agencies have different rules and regulations. Therefore it's very important that we are informed about the required classification in order to offer the correct winch to you. Furthermore details about the application are required to determine the required technical specifications.

Prices and drawings are available upon request. Please let us have your specifications.

Standard features

- Selfbraking worm-, helical or planetary gear transmissions
- Electric 400 V AC / 3-phases / 50 Hz motor.
- Hydraulic orbit, radial piston or axial piston motors
- Pneumatic gear or radial piston motors
- Primary brake on motor
- Secondary brake on winch drum
- Full material trace-ability (3.1 – EN 10204) on structural steel components
- Two drum supports
- Double layer 2-component conservation according ISO 12944 category C2-Low, colour RAL 5010

Available control options

- electric /hydraulic or pneumatic control systems
- Limit switches
- Slack wire witches
- Overload protection
- Emergency hand crank

Available options

- Explosion-proof motors
- Protective steel motor cover
- Drum pressure roller
- Drum guard
- Marine / offshore coating systems
- Spooling gear
- Grooved drum
- Split drums / additional rope anchors / etc.
- Third party design review (LRS, ABS, DNV, etc)

MR 30 FLG



150 KG DEDICATED PNEUMATIC MANRIDING WINCH. FOR OFFSHORE APPLICATIONS SUPPLIED WITH LRS, ABS, DNV DESIGN APPROVAL. FOR ONSHORE APPLICATIONS SUPPLIED WITH CE TYPE EXAMINATION CERTIFICATE.

SB 307/185 EVSP



650 KG EEXD ELECTRIC PERSONAL BASKET WINCH FOR GASHOLDER (POSCO, SAARSTAHL, ARCELOR) SUPPLIED WITH EC TYPE EXAMINATION CERTIFICATE

OHR 3.0 BD



3 TON HYDRAULIC DIVING BELL AND CLUMP WEIGHT WINCH WITH LRS DESIGN APPROVAL.

OHR 3.0 BDGP

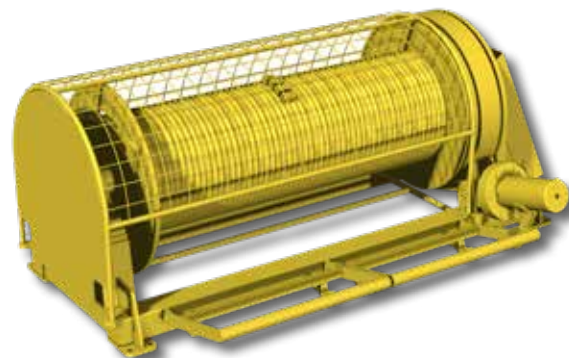

3 TON HYDRAULIC PERSONAL LIFTING WINCH FOR MAINTENANCE BASKET. SUPPLIED WITH DNV DESIGN APPROVAL AND CE TYPE EXAMINATION CERTIFICATE

SB315R HBDGL



11,5 TON HYDRAULIC DIVING BELL WINCH WITH GL DESIGN APPROVAL

OMR 3.0 LPR6 BD

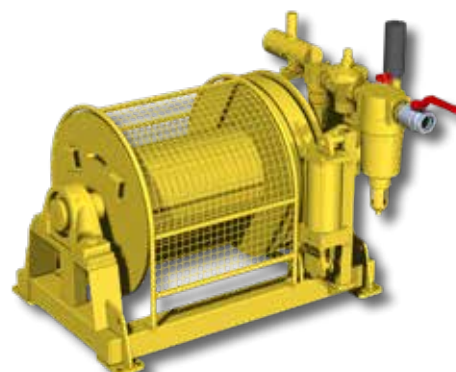

3 TON PNEUMATIC DIVING BELL AND CLUMP WEIGHT WINCH WITH LRS DESIGN APPROVAL

A range of compact lifting and pulling winches utilising electric or hydraulic motors.

The heavy duty planetary gearbox is located within the drum core, which both saves space and protects the gearbox from any external mechanical threats.

Capacities can go up to 30 tons of lifting capacity with this range. Depending on your power source and application, we can select and offer the correct model for you.

Standard features

- Heavy duty planetary gearbox
- SC E IP 54 400 V AC / 3-phases / 50 Hz braked motor
- SC H; orbit or radial piston type hydraulic motor complete with brake valve
- Steel drum with cable fixing point at flange
- Two drum supports
- Double layer 2-component conservation according ISO 12944 category C2-Low, colour RAL 5010
- FEM / ISO class: T4-L3-M5

- Alternative speeds
- Alternative supply voltages
- Drum guards
- Spooling gears
- Grooved drums
- Marine / offshore coating systems

Available control options

Available options

- IP 56 TENV cast iron motor for marine applications
- Explosion-proof motors
- Protective steel motor cover
- Drum pressure roller
- Band brakes (manual or fail-safe automatic)
- Manually disengaging clutch

- Control box IP 55 with push-buttons and emergency stop built acc. to NEN 1010
- Control box IP 66 with low-voltage IP 65 remote control built acc. to NEN 1010
- Load limiter (required by CE for applications exceeding 1000 kg WLL.)
- Frequency inverter for variable speed control
- Wireless radio remote control systems
- Limit switches (electric)
- Flange encoder
- Slack wire switches (electric)
- Proportional local or remote control valve (hydraulic)

Winch type	WLL 1 st layer kg	WLL. top layer kg	Recomm. rope diam. mm	Speed 1 st layer m/min.	Speed top layer m/min.	Drumcap. top layer m	Motor power in kW
SC 15 E	1955	1500 (5)	12	8	10	178 (5)	3
SC 20 E	2655	2000 (5)	13	11	14	167 (5)	5,5
SC 25 E	3500	2500 (5)	16	8	11	144 (5)	5,5
SC 35 E	4850	3500 (5)	18	8	11	181 (5)	7,5
SC 50 E	6880	5000 (5)	20	8	11	203 (5)	11
SC 67 E	9700	6700 (5)	24	12	17	195 (5)	22
SC 85 E	12160	8500 (5)	26	9	13	228 (5)	22
SC 110 E	15910	11000 (5)	30	7	10	228 (5)	22
SC 140 E	18555	14000 (4)	32	6	8	204 (4)	22
SC 175 E	23215	17500 (4)	38	6,5	8,5	223 (4)	30
SC 220 E	29550	22000 (4)	40	6	8	214 (4)	37

Winch type	WLL 1 st layer kg	WLL. top layer kg	Recomm. rope diam. mm	Speed 1 st layer m/min.	Speed top layer m/min.	Drumcap. top layer m	Flow in l/min.	Pressure drop in bar
SC 15 H	1955	1500 (5)	12	19	25	178 (5)	60	125
SC 20 H	2655	2000 (5)	13	11	14	167 (5)	60	115
SC 25 H	3500	2500 (5)	16	12	16	144 (5)	60	135
SC 35 H	4850	3500 (5)	18	11	15	181 (5)	60	160
SC 50 H	6880	5000 (5)	20	12	16	203 (5)	70	200
SC 67 H	9700	6700 (5)	24	12	17	195 (5)	90	220
SC 85 H	12160	8500 (5)	26	12	17	228 (5)	100	235
SC 110 H	15910	11000 (5)	30	10	14	228 (5)	120	220
SC 140 H	18555	14000 (4)	32	9	12	204 (4)	115	250
SC 175 H	23215	17500 (4)	38	10	13	223 (4)	155	240
SC 220 H	29550	22000 (4)	40	9	12	214 (4)	175	245

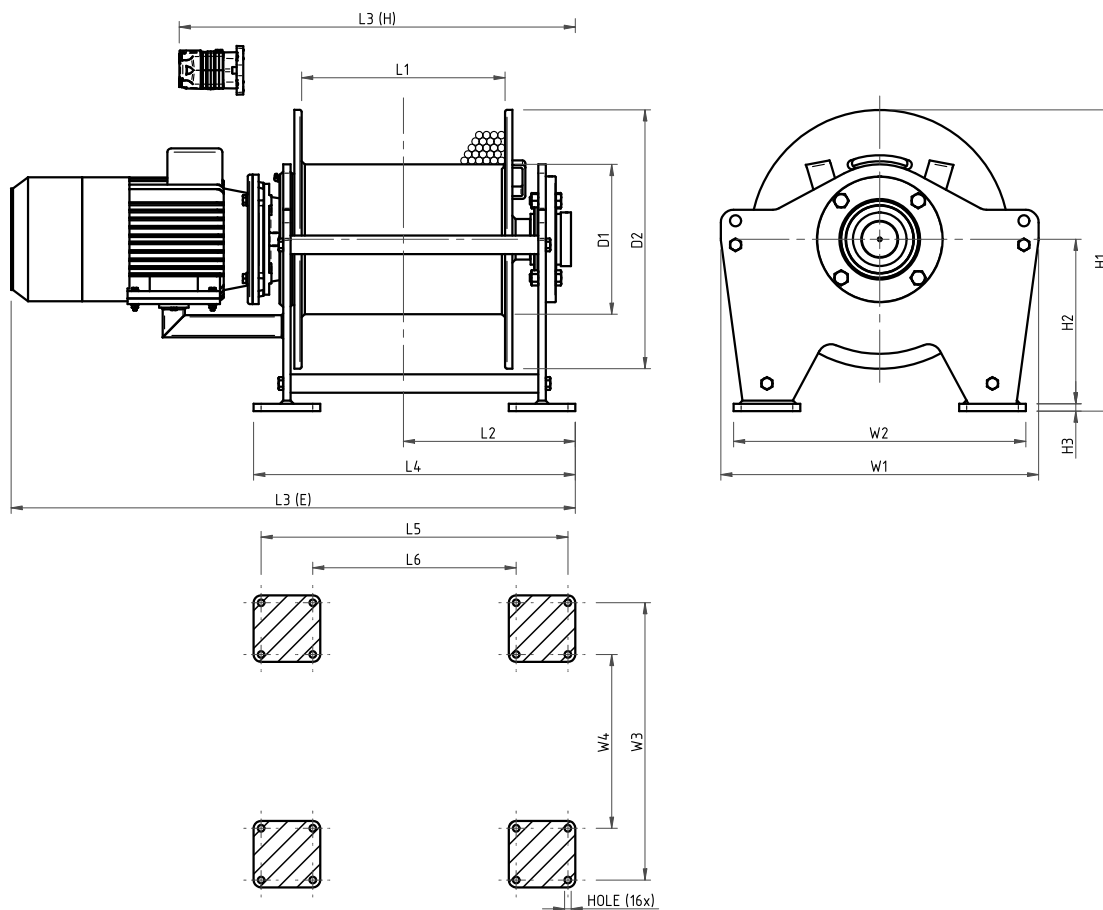

FOOTPRINT -TOP VIEW- A-A

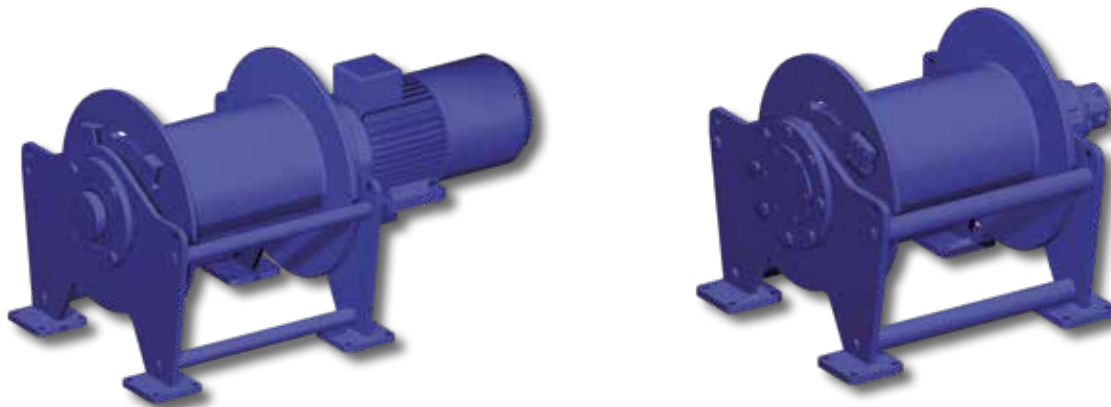

Type	Mass (kg)	D1	D2	L1	L2	L3 E	L3 H	L4	L5	L6	H1	H2	H3	W1	W2	W3	W4	Hole Ø
SC 15	315	305	500	400	322	1012	812	625	595	375	610	345	15	660	550	520	300	14
SC 20	425	305	500	400	360	1246	872	680	640	400	615	345	20	660	570	530	290	14
SC 25	470	305	550	410	375	1266	887	700	660	420	665	370	20	710	620	580	340	14
SC 35	660	355	700	500	430	1382	973	810	770	490	815	445	20	860	790	750	470	18
SC 50	810	405	700	550	465	1526	1071	870	830	550	815	445	20	860	790	750	470	18
SC 67	1120	405	750	610	528	1718	1192	980	930	630	870	470	25	950	860	810	510	26
SC 85	1350	455	850	690	582	1816	1332	1075	1025	725	970	520	25	1050	960	910	610	26
SC 110	1675	508	950	720	623	1950	1412	1140	1090	750	1070	570	25	1150	1080	1030	690	26
SC 140	2245	558	1050	820	685	2062	1495	1280	1220	820	1170	615	30	1330	1220	1160	760	33
SC 175	2920	660	1150	900	735	2353	1814	1380	1300	900	1270	665	30	1430	1340	1260	860	39
SC 220	3450	660	1250	900	748	2487	1848	1400	1320	920	1375	715	35	1530	1440	1360	960	39

The Standard build SB winch celebrates its 40 years in production this year. Over the years it has become an archetypal winch that can be found in the inventory of many users, rental fleets and catalogues. Sturdy, effective and economical to produce, the SB winches found many customers around the world in as many applications. Over the years SB winches gained hydraulic and pneumatic motors, clutches, band brakes and spooling gears, ATEX versions and versions that can work at arctic temperatures or in the high ambient temperatures found steel mills or kilns.

Advanced and more energy efficient motors and controls make sure the SB series conforms to modern day expectations regarding the environment and total cost of ownership. As ever the SB series remains a highly adaptable and efficient winch platform that can be modified and adapted to fit almost any customer demand of ambition.

Standard winch features

- Heavy duty planetary gearbox
- SB E; IP 54 400 V AC / 3-phases / 50 Hz braked motor
- SB H; orbit or radial piston type hydraulic motor complete with brake valve
- SB LPR; radial piston type air motor complete with hand control valve and mufflers
- SB LG; gear type air motor complete with hand or remote control valve and mufflers
- Steel drum with cable fixing point at flange
- Two drum supports
- Double layer 2-component conservation according ISO 12944 category C2-Low, colour RAL 5010
- FEM / ISO class: T3-L3-M4

- Alternative supply voltages
- Drum guards
- Spooling gears
- Grooved drums
- Manual emergency crank
- Slip ring mounting
- Alternative drum dimensions / split drums / additional rope anchors / etc.
- Warping head
- Marine / offshore coating systems

Available winch options

- IP 56 TENV cast iron motor for marine applications
- Explosion-proof motors
- Protective steel motor cover
- Drum pressure roller
- Band brakes (manual or fail-safe automatic)
- Manual disengaging clutch
- Alternative speeds

Available control options

- Control box IP 55 with push-buttons and emergency stop built acc. to NEN 1010
- Control box IP 66 with low-voltage IP 65 remote control built acc. to NEN 1010
- Load limiter (required by CE for applications exceeding 1000 kg WLL)
- Frequency inverter for variable speed control
- Wireless radio remote control systems
- Limit switches (electric, pneumatic)
- Slack wire switches (electric, pneumatic)
- Proportional local or remote control valve (pneumatic or hydraulic)

Winch type Electric	WLL 1 st layer kg	WLL 5 th layer kg	Recomm. rope diam. mm	Speed 1 st layer m/min.	Speed 5 th layer m/min.	Drumcap. 1 st layer m	Drumcap. 5 th layer m	Motor power kW
SB 300 E	1200	845	10	9,5	14	26	168	2.2
SB 301 E	2100	1435	12	7	10	24	157	3
SB 303 E	2500	1740	14	11	16	26	165	5.5
SB 304 E	3100	2160	14	9	13	26	165	5.5
SB 305 E	4000	2770	16	7	10.5	25	161	5.5
SB 306 E	5500	3970	18	7	10	28	181	7.5
SB 307 E	7000	4960	22	12	17	26	171	15
SB 309 E	9000	6285	26	14	19.5	24	163	22
SB 310 E	12000	8460	28	8	12	24	168	18.5
SB 311 E	16000	10655	34	7	11	19	144	22
SB 313 E	20000	13610	38	6	8.5	19	151	22
SB 314 E	24000	16170	40	6.5	9.5	19	154	30
SB 315 E	30500	20800	44	6	9	19	151	37
SB 316 E	37000	24570	48	6	9	17	141	45

Winch type Hydraulic	WLL 1 st layer kg	WLL 5 th layer kg	Recomm. rope diam. mm	Speed 1 st layer m/min	Speed. 5 th layer m/min	Drumcap. 1 st layer m	Drumcap. 5 th layer m	Pressure drop in bar	Flow in l/min.
SB 303 H	2500	1740	14	18	26	26	165	140	60
SB 304 H	3100	2160	14	15	21	26	165	140	60
SB 305 H	4000	2770	16	18	26	25	161	190	70
SB 306 H	5500	3970	18	25	35	28	181	225	95
SB 307 H	7000	4960	22	20	28	26	171	230	100
SB 309 H	9000	6285	26	13	18	24	163	190	100
SB 310 H	12000	8460	28	11	16	24	168	230	95
SB 311 H	16000	10655	34	10	15	19	144	230	110
SB 313 H	20000	13610	38	8	12	19	151	210	120
SB 314 H	24000	16170	40	8	11	19	154	240	120
SB 315 H	30500	20800	44	8	12	19	151	235	165
SB 316 H	37000	24570	48	6	9	17	141	225	160

Winch type Pneumatic Piston motor	WLL 1 st layer kg	WLL 5 th layer kg	Recomm. Rope diam. mm	Average Speed* m/min.	Maximum Speed** m/min.	Drumcap. 1 st layer m	Drumcap. 5 th layer m	Pressure drop in bar	Flow in l/sec.
SB 300 LPR2	1200	845	10	13	18	26	168	7	90
SB 301 LPR2	2100	1435	12	8	12	24	157	7	90
SB 303 LPR2	2500	1740	14	7	10	26	165	7	90
SB 303 LPR3	2500	1740	14	15	26	26	165	7	140
SB 304 LPR3	3100	2160	14	13	19	26	165	7	140
SB 305 LPR3	4000	2770	16	11	17	25	161	7	140
SB 305 LPR4	4000	2770	16	18	24	25	161	7	240
SB 306 LPR4	5500	3970	18	12	15	28	181	7	240
SB 307 LPR4	7000	4960	22	10	13	26	171	7	240
SB 309 LPR4	9000	6285	26	8	12	24	163	7	240

Winch type Pneumatic Gear motor	WLL 1 st layer kg	WLL 5 th layer kg	Recomm. Rope diam. mm	Average Speed* m/min.	Maximum Speed** m/min.	Drumcap. 1 st layer m	Drumcap. 5 th layer m	Pressure drop in bar	Flow in l/sec.
SB 300 GP2	1200	845	10	10	15	26	165	7	65
SB 301 GP4	2100	1435	12	8	12	24	157	7	100
SB 303 GP4	2500	1740	14	6	9	26	165	7	100
SB 304 GP6	3100	2160	14	10	14	26	165	7	200
SB 305 GP6	3500	2400	16	9	16	26	165	7	200
SB 306 GP10	5500	3970	18	12	23	28	181	7	300
SB 307 GP10	7000	4960	22	10	18	26	171	7	300
SB 307 GP16	7000	4960	22	15	35	26	171	7	350
SB 309 GP10	9000	6285	26	7	13	24	163	7	300
SB 309 GP16	9000	6285	26	11	27	24	163	7	350
SB 310 GP16	12000	8460	28	8	20	24	168	7	350
SB 311 GP16	16000	10655	34	6	15	19	144	7	350
SB 313 GP16	20000	13610	38	5	12	19	151	7	350

* Average speed is based on the speed in the middle layer at 75% of W.L.L.

** Maximum speed is based on the speed in the top layer at unloaded conditions

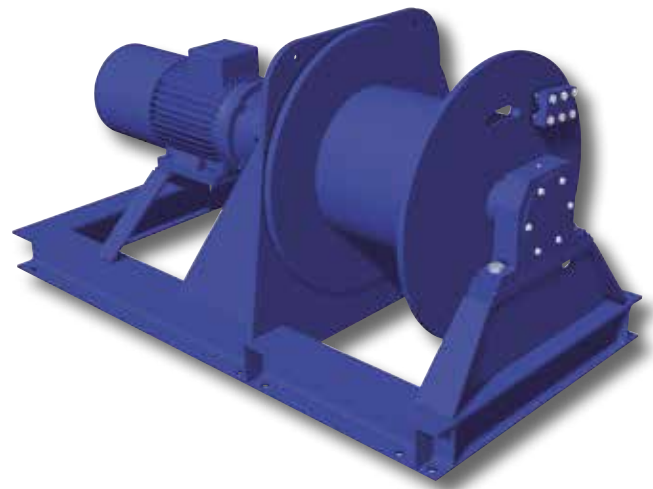
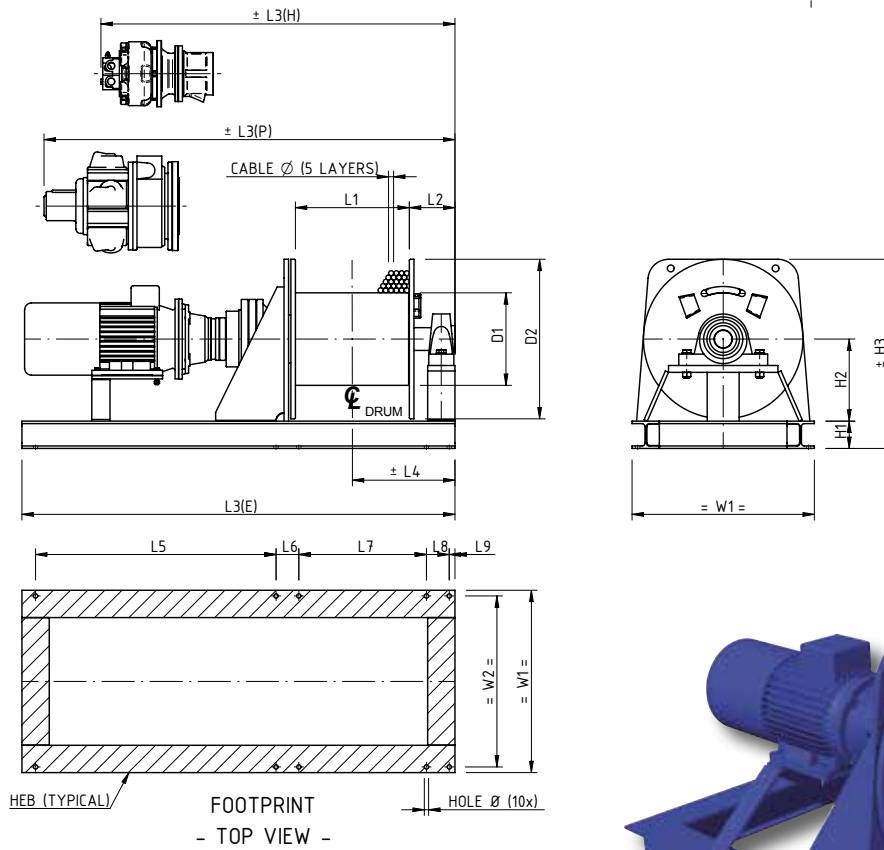

Winch type	Mass (kg)	D1	D2	L1	L2	L3(E)	L3(H)	L3(P)	L4	L6	L7	L8	L9	H1	H2	H3	W1	W2	Heb	Hole Ø
300	260	178	410	500	135	1400	-	1450	385	80	530	80	20	100	215	520	500	460	100	14
301	270	195	410	500	140	1400	-	1450	390	80	530	80	20	100	215	520	500	460	100	14
303	390	244	500	500	145	1650	1350	1650	395	80	540	80	20	100	260	610	600	560	100	14
304	405	244	500	500	145	1650	1350	1800	395	80	540	80	20	100	260	610	600	560	100	14
305	410	272	500	500	155	1700	1350	1800	405	80	550	80	20	100	260	610	600	560	100	14
306	525	355	600	500	155	1700	1450	1850	405	80	550	80	20	100	310	710	700	660	100	18
307	825	406	700	500	200	1950	1550	1900	450	100	560	100	25	120	360	830	800	750	120	20
309	1215	455	850	500	230	2100	1550	1900	480	110	580	110	30	140	435	1000	1000	940	140	22
310	1470	508	900	500	230	2100	1600	1950	480	120	550	120	40	160	460	1070	1100	1040	160	26
311	1690	508	1000	500	245	2150	1600	1950	495	120	570	120	40	160	510	1170	1150	1090	160	30
313	2270	610	1150	500	265	2250	1700	1950	515	120	600	120	40	180	585	1340	1350	1280	180	33
314	3200	660	1250	500	265	2500	2000	-	515	140	600	140	40	200	635	1460	1450	1370	200	39
315	3550	711	1350	500	300	2650	2050	-	550	140	610	140	40	200	685	1560	1550	1470	200	39
316	3865	711	1400	500	305	2700	2100	-	565	140	615	140	40	200	710	1610	1600	1520	200	39

SB series references

SB 303 EDGP

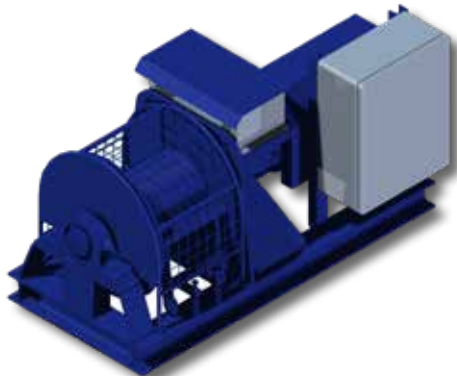

SB 303 EDGP INCLUDING DRUM GUARD, GROOVED DRUM ,
PRESSURE ROLLER, RAINCOVER OVER MOTOR,
AND CONTROL PANEL WITH FREQUENCY INVERTER

SB 311 R EDPS

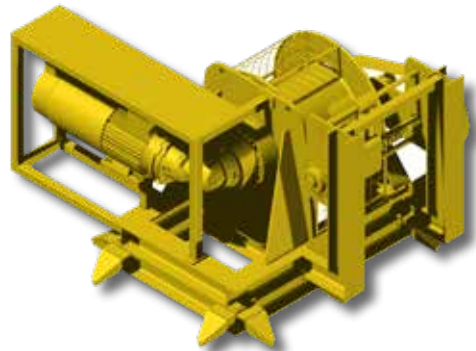

SB 311 R EDPS INCLUDING RIGHT ANGLE GEARBOX, DRUM
GUARD, PROTECTIVE FRAME AROUND MOTOR, SPOOLING
GEAR AND COUNTER FOUNDATION FOR DECK WELDING

SB 310 H



SB 310 H INCLUDING PROPORTIONAL CONTROL VALVE
AND FILTER UNIT

SB 310 HDPS

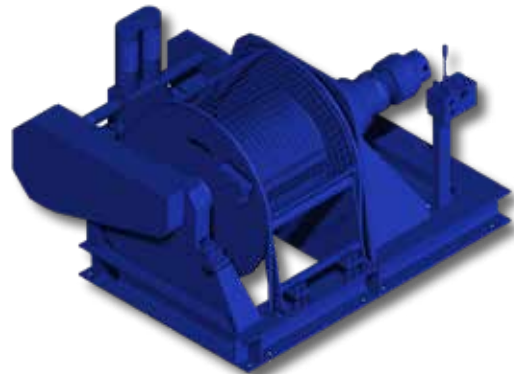

SB 310 HDPS INCLUDING DRUM GUARD, PRESSURE ROLLER,
SPOOLING GEAR AND PROPORTIONAL CONTROL VALVE

SB 306 GP16P

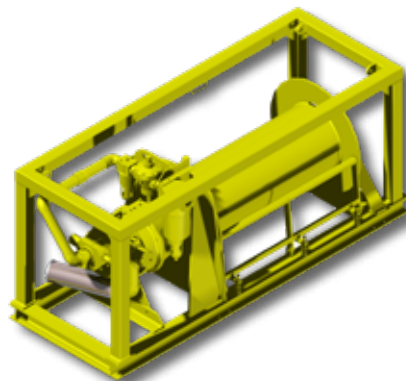

SB 306 GP16P INCLUDING PRESSURE ROLLER, AIR SERVICE
UNIT AND OFFSHORE FRAME

Specially designed for applications where space is at a premium, these compact and lightweight lifting winches are ideally suited for installation on cranes, davits and derricks. The single drum support enables the rope to leave the drum at any angle. The heavy duty planetary drive is partly located within and protected by the drum core. The large drum diameters ensure a healthy drum to cable diameter ratio and a sufficient working length despite the short drums.

Standard features

- Heavy duty planetary gearbox
- FD E; IP 54 400 V AC / 3-phases / 50 Hz braked motor
- FD H; orbit or radial piston type hydraulic motor complete with brake valve
- FD GP gear type air motor complete with hand control valve and mufflers
- Steel drum with cable fixing point at flange
- Single drum support
- Double layer 2-component conservation according ISO 12944 category C2-Low, colour RAL 5010
- FEM / ISO class: T4-L3-M5

- Alternative speeds
- Alternative supply voltages
- Drum guards
- Marine / offshore coating systems
- Tubular offshore frame construction with lifting eyes

Available control options

Available options

- IP 56 TENV cast iron motor for marine applications
- Explosion-proof motors
- Protective steel motor cover
- Drum pressure roller

- Control box IP 55 with push-buttons and emergency stop built acc. to NEN 1010
- Control box IP 66 with low voltage IP 65 remote control built acc. to NEN 1010
- Load limiter (required by CE for applications exceeding 1000 kg WLL)
- Frequency inverter for variable speed control
- Wireless radio remote control systems
- Limit switches
- Slack wire switches
- Radio / Infra red remote control

Winch type Electric	WLL 1 st layer kg	WLL top layer kg	Recomm. rope diam. mm	Speed 1 st layer m/min.	Speed top layer m/min.	Drumcap. 1 st layer m	Drumcap. all layers m	Motor power 400 VAC kW	
FD 300 E	950	800 (4)	8	8.5	10	15	70 (4)	1.5	
FD 301 E	1850	1470 (4)	11	9	11	10	53 (4)	3	
FD 303 E	2300	1970 (3)	12	7	8.5	11	41 (3)	3	
FD 304 E	2800	2340 (3)	14	10	12	9	36 (3)	5.5	
FD 305 E	3350	2800 (3)	14	9	11	10	40 (3)	5.5	
FD 306 E	4100	3500 (3)	16	7	8.5	15	56 (3)	5.5	
FD 307 E	5250	4490 (3)	18	12	14	18	67 (3)	11	
Winch type Hydraulic	WLL 1 st layer kg	WLL top layer kg	Recomm. rope diam. mm	Speed 1 st layer m/min.	Speed top layer m/min.	Drumcap. 1 st layer m	Drumcap. all layers m	Pressure drop in bar	Flow in l/min.
FD 300 H	950	800 (4)	8	30	35	15	70 (4)	140	35
FD 301 H	1850	1470 (4)	11	20	25	10	53 (4)	130	55
FD 303 H	2300	1970 (3)	12	15	17	11	41 (3)	130	50
FD 304 H	2800	2340 (3)	14	17	20	9	36 (3)	140	60
FD 305 H	3350	2800 (3)	14	13	16	10	40 (3)	135	60
FD 306 H	4100	3500 (3)	16	13	15	15	56 (3)	140	70
FD 307 H	5250	4490 (3)	18	13	15	18	67 (3)	170	70

Winch type Pneumatic	WLL 1 st layer kg	WLL top layer kg	Recomm. rope diam. mm	Average Speed* m/min	Maximum Speed** m/min	Drumcap. 1 st layer m	Drumcap. 5 th layer m	Pressure drop bar	Flow in l/sec
FD 300 GP2	950	800 (4)	8	11	14	15	70 (4)	7	65
FD 301 GP2	1500	1200 (4)	11	7	10	10	53 (4)	7	65
FD 301 GP4	1850	1470 (4)	11	10	14	10	53 (4)	7	100
FD 303 GP4	2300	1800 (3)	12	8	12	11	41 (3)	7	100
FD 304 GP4	2600	2200 (3)	14	6	9	9	36 (3)	7	100
FD 304 GP6	2600	2200 (3)	14	13	19	9	36 (3)	7	200
FD 305 GP6	3350	2800 (3)	14	10	15	9	36 (3)	7	200
FD 306 GP10	4100	3500 (3)	16	14	24	15	56 (3)	7	300
FD 307 GP10	5250	4490 (3)	18	10	18	18	67 (3)	7	300

* Average speed is based on the speed in the middle layer at 75% of W.L.L.

** Maximum speed is based on the speed in the top layer at unloaded conditions

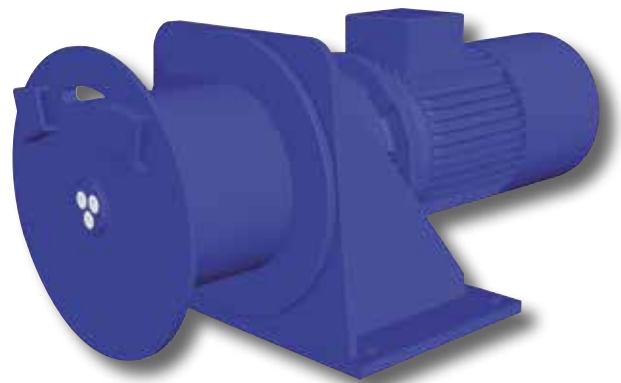
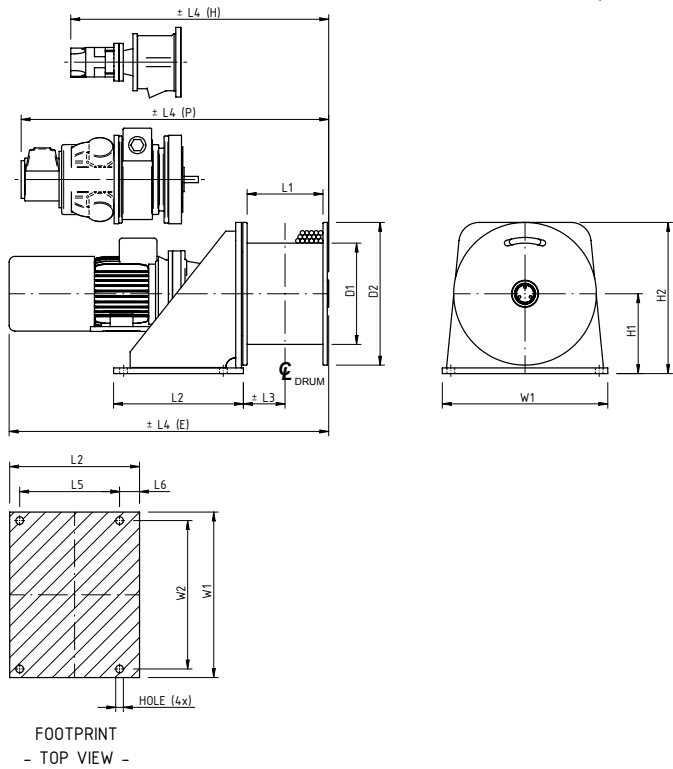

Type	Mass	D1	D2	L1	L2	L3	L4(E)	L4(H)	L4(P)	L5	L6	H1	H2	W1	W2	Hole Ø
FD 300	130	244	380	176	310	96	733	520	765	240	44	215	405	440	400	18
FD 301	140	244	380	176	310	96	760	558	785	240	44	215	405	440	400	18
FD 303	180	272	410	191	350	107	818	595	905	275	50	235	440	500	450	22
FD 304	230	272	410	191	350	107	1012	595	905	275	50	235	440	500	450	22
FD 305	255	272	410	210	350	116	1030	625	950	275	50	235	440	500	450	22
FD 306	365	355	500	266	455	146	1098	780	1110	350	70	285	535	580	520	27
FD 307	535	406	625	310	510	172	1316	885	1215	400	75	348	660	750	680	27

A range of standard hydraulic planetary winches, developed for heavy duty lifting and pulling applications of up to 10,000 kg where compactness is required. Due to the standard design, they can be supplied within short delivery times. All winches are fitted with a brake as standard that makes them suitable for lifting applications.

Standard features

- Planetary transmission
- Orbit motor
- Steel drum (not grooved) with cable fixing point at flange
- Two drum supports
- Single layer of primer only, colour black
- Brake and single acting brake valve

Available control options

- Proportional control valves
- Hydraulic power packs
- Electric lower limit switch
- Load limiter

Available options

- Grooved drum
- Drum pressure roller
- Drum guards

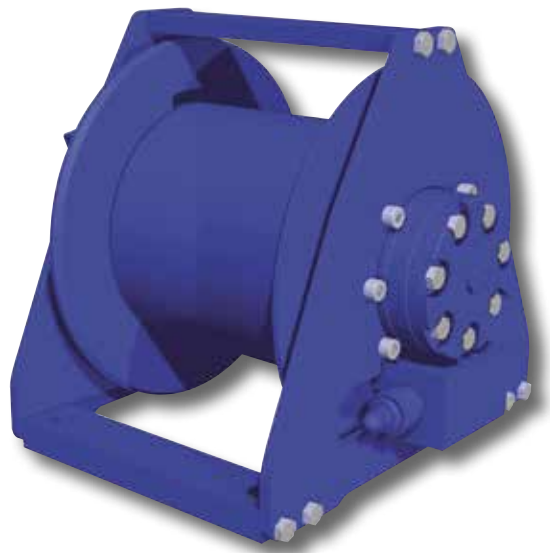

Winch type Hydraulic	WLL 1 st layer kg	WLL top layer kg	Recomm. rope diam. mm	Speed 1 st layer m/min.	Drumcap. 1 st layer m	Drumcap. all layers m	Pressure drop in bar	Flow in l/min.	Main ports BSP	Drain ports BSP
SH 05	600	480	6	42	14	63 (4)	175	25	3/8"	-
SH 08	800	610	7	38	13	74 (5)	165	30	3/8"	-
SH 10	1000	790	8	38	11	50 (4)	175	40	3/8"	-
SH 15	1500	1190	9	43	13	59 (4)	190	50	1/2"	1/4"
SH 20	2000	1560	10	34	11	53 (4)	200	50	1/2"	1/4"
SH 25	2500	1950	12	29	12	54 (4)	205	50	1/2"	1/4"
SH 34	3400	2680	14	47	15	72 (4)	205	100	3/4"	1/4"
SH 47	4700	3410	16	36	20	120 (5)	220	100	3/4"	1/4"
SH 57	5700	4410	18	27	22	101 (4)	205	100	3/4"	1/4"
SH 60	6000	4680	18	29	22	99 (4)	200	120	3/4"	1/4"
SH 70	7000	5460	20	25	23	108 (4)	200	120	3/4"	1/4"
SH 85	8500	6670	20	19	28	128 (5)	195	120	1"	1/4"
SH 100	10000	7690	24	17	26	121 (4)	205	120	1"	1/4"

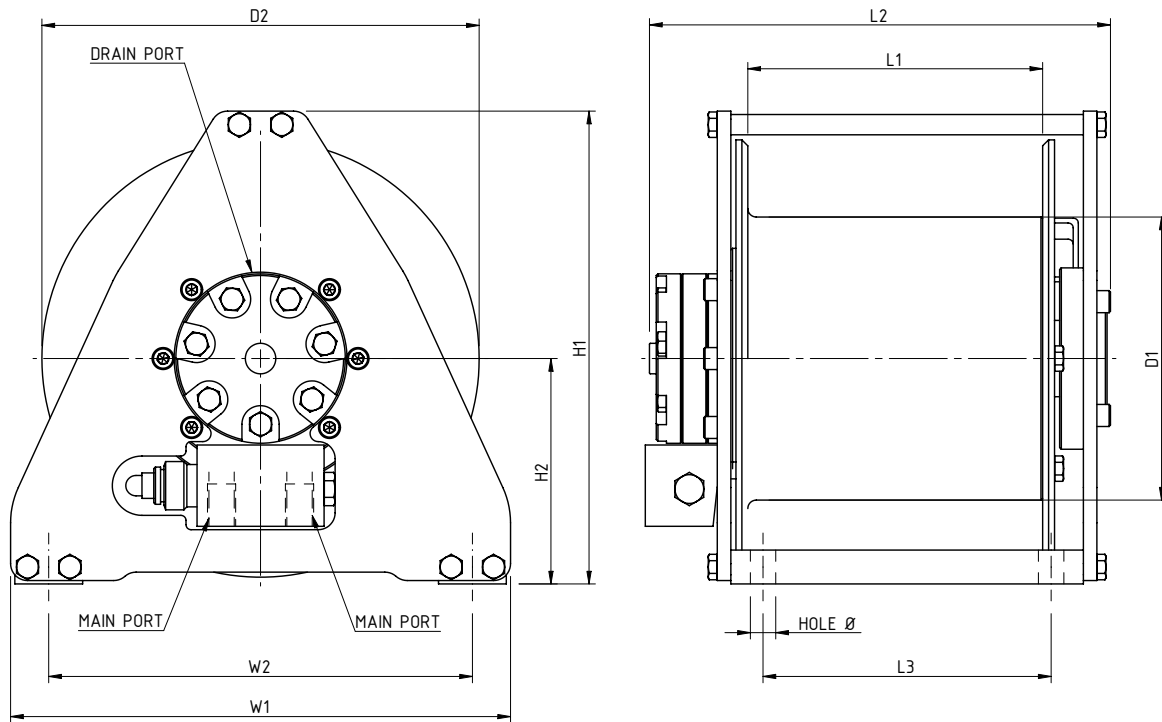

Winch type	Mass (kg)	D1	D2	L1	L2	L3	W1	W2	H1	H2	Hole Ø
SH 05	36	146	220	132	275	175	218	180	240	117	11
SH 08	40	167	258	174	275	170	295	250	279	133	15
SH 10	41	167	258	174	275	170	295	250	279	133	15
SH 15	71	202	312	187	319	170	315	250	348	175	15
SH 20	71	202	312	187	325	170	315	250	348	175	15
SH 25	95	243	376	191	352	190	405	350	403	195	17
SH 34	167	296	454	242	432	250	426	350	498	245	17
SH 47	258	322	530	321	510	330	610	530	566	271	25
SH 57	296	353	570	360	570	375	630	550	612	292	25
SH 60	350	366	580	360	751	360	-	530	630	295	23
SH 70	415	404	610	378	780	380	640	550	620	315	23
SH 85	430	418	640	430	851	435	694	590	665	345	23
SH 100	700	455	720	444	1008	470	788	670	745	385	23

A comprehensive range of standard winches with a high performance gearbox developed for heavy duty pulling and lifting duties of up to 2,700 kg. This broad range comprises a variation of very compact winches and each type is standard available with a choice of 3 different speeds. Drum lengths can easily be adapted to customer requirements.

Standard features

- High efficiency transmission
- IP 54 400 V AC / 3-phases / 50 Hz braked motor
- Steel drum (not grooved) with cable fixing point at flange
- Two drum supports (all other models)
- Double layer 2-component conservation according ISO 12944 category C2-Low, colour RAL 5010
- FEM / ISO class: T3-L3-M4

- Grooved drum
- Motor position vertically up
- Drum pressure roller
- Alternative speeds
- Alternative drum dimensions / split drums / additional rope anchors / etc.
- Drum guards
- Marine / offshore coating systems

Available options

- IP 56 TENV cast iron motor for marine applications
- 230 VAC single-phase motors (up to 1.8 kW)
- 24 V DC motors
- Hydraulic motors
- Explosion-proof motors
- Manual or remotely controlled disengaging clutch
- Protective steel motor cover
- Band brakes

Available control options

- Control box IP 55 with push-buttons and emergency stop built acc. to NEN 1010
- Control box IP 66 with low voltage IP 65 remote control built acc. to NEN 1010
- Load limiter
- Frequency inverter for variable speed control
- Wireless radio remote control systems
- Limit switches
- Slack wire switches

Winch type Electric	WLL 1st layer kg	WLL 5th layer kg	Speed 1st layer m/min.	Speed 5th layer m/min.	Recomm. Rope diam. mm	Drumcap. 1st layer m	Drumcap. 5th layer m	Motor power kW	"x" max.
A20L	500	345	3	4.5	6	7	48	0.37	568
A20M	500	345	8.5	12.5	6	7	48	0.75	555
A20H	500	345	16	23	6	7	48	1.50	595
A20 SP220	500	345	8.5	12.5	6	7	48	1.10	600
A30L	600	400	3	4.5	8	6	44	0.37	585
A30M	650	435	8.5	13	8	6	44	1.10	612
A30H	650	435	13	19.5	8	6	44	1.50	612
A35L	900	600	4	6	8	6	44	0,75	602
A35M	900	600	8,5	13	8	6	44	1,5	629
A35H	900	600	12	18	8	6	44	2,2	676
A41L	1200	820	4.5	7	9	10	62	1.10	683
A41M	1200	820	6	8.5	9	10	62	1.50	683
A41H	1200	820	13	19	9	10	62	3.00	707
A41 SP220	1000	685	6	8.5	9	10	62	1.50	707
A50L	1800	1205	4.5	7	11	10	74	1.50	730
A50M	1800	1205	7	10	11	10	74	2.20	730
A50H	1800	1205	12.5	19	11	10	74	4.00	755
A55L	2200	1460	5	8	12	10	72	2,2	749
A55M	2200	1460	7	10	12	10	72	3	749
A55H	2200	1460	13	20	12	10	72	5,5	953
A60L	2700	1800	4.5	7	14	17	117	2.20	840
A60M	2700	1800	8	12	14	17	117	4.00	792
A60H	2700	1800	14	21	14	17	117	7.50	971

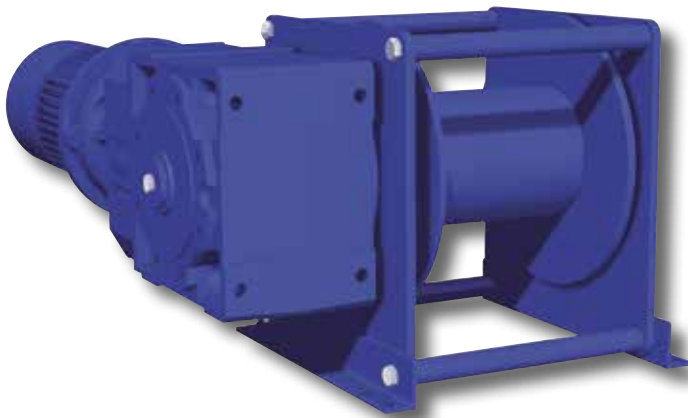
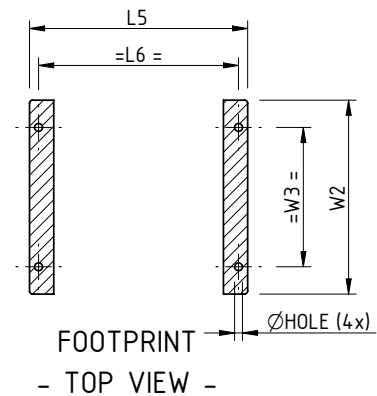
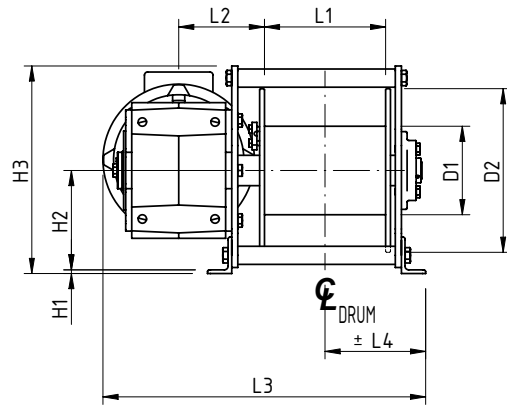
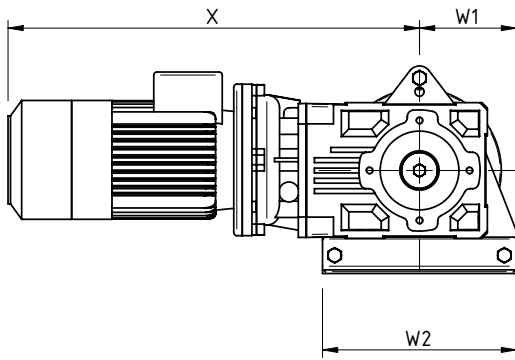

A type electric

Type	Mass (kg)	D1	D2	L1	L2	L3	L4	L5	L6	H1	H2	H3	W1	W2	W3	Hole Ø
A 20	65	100	175	150	116	430	139	305	275	6	164	342	160	320	230	13 (4x)
A 30	70	121	225	150	129	445	139	310	280	6	164	342	160	320	230	13 (4x)
A 35	90	121	225	150	134	455	141	310	280	6	164	342	160	320	230	13 (4x)
A 41	110	146	270	200	141	533	166	360	330	6	164	343	160	320	230	13 (4x)
A 50	190	168	350	250	168	620	198	425	395	6	239	420	215	430	390	13 (8x)
A 55	220	178	350	250	168	645	198	425	395	6	239	420	215	430	390	13 (8x)
A 60	290	210	390	400	180	815	270	575	545	6	239	440	235	470	430	13 (8x)

The standard build SR type winch is the basis of the solution to many pulling and lifting winch applications. The winch is constructed with a slew ring in a combination with 3 or more planetary drives and motors. Capacities can go up to 75 tons of lifting capacity with this range.

Although the name of this winch indicates different, these winches are very suitable to suit your specific winch application. Several options can be offered on these highly versatile winches. Prices and drawings will be supplied upon request.

Standard winch features

- Heavy duty slew ring
- Heavy duty planetary gearboxes fitted with pinions
- SR E IP 54 400 V AC / 3-phases / 50 Hz braked motors
- SR H orbit or radial piston type hydraulic motor complete with brake valve
- Steel drum with cable fixing point at flange
- Double layer 2-component conservation according ISO 12944 category C2-Low, colour RAL 5010
- FEM / ISO class: T3-L3-M4

- Warping head
- Marine / offshore coating systems
- Tubular offshore frame with lifting eyes

Available control options

- Control box IP 55 with pushbuttons and emergency stop built acc. to NEN 1010
- Control box IP 66 with low voltage IP 65 remote control built acc. to NEN 1010
- Load limiter (required by CE for applications exceeding 1000 kg WLL)
- Frequency inverter for speed control
- Wireless radio remote control systems
- Limit switches
- Slack wire switches
- Proportional local or remote control valve

Available winch options

- IP 56 TENV cast iron motors
- Explosion-proof motors
- Protective steel motor cover
- Band brakes (manual or fail-safe automatic)
- Alternative speeds
- Alternative supply voltages
- Drum guards
- Spooling gears
- Grooved drums
- Slip ring or swivel mounting
- Alternative drum dimensions / split drums / additional rope anchors / etc.

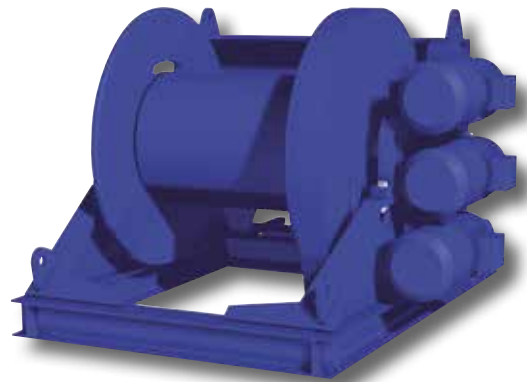

Winch type	WLL 1 st layer kg	WLL 5 th layer kg	Recomm. rope diam. mm	Speed 1 st layer m/min.	Speed 5 th layer m/min.	Drumcap. 1 st layer m	Drumcap. 5 th layer m	Motor power kW
SR 30 E3	43000	30000	44	7	10	42	290	66
SR 40 E3	57000	40000	52	6	8	40	290	66
SR 50 E4	73000	50000	56	6	8	37	275	74
SR 30 H3	41000	30000	44	7	10	42	290	66
SR 40 H3	57000	40000	52	6	8	40	290	66
SR 50 H4	73000	50000	56	6	8	37	275	74

Traction winches are mainly built for purpose. Winches are built to order and can be executed with a self-braking wormgear or planetary gear depending on the load required. The drive can be either electric, hydraulic or pneumatic. The winches are mainly used for traversing applications where a compact but heavy duty system is required. EMCÉ has supplied systems up to and including 10,000 kg.

We have supplied solutions for the following opening and closing of hangar doors, moving railcars along a track, deep sea research and moving trolleys on a cable or at ground. Systems can be supplied with endless cables or with a separate wire spooling unit.

Prices and drawings are available upon request. Please let us have your specifications.

Standard features

- Selfbraking wormgear or planetary gear transmissions
- IP 54 400 V AC / 3-phases / 50 Hz non braked motor. (440 / 3 / 60)
- Steel sheaves
- Double layer 2-component conservation according ISO 12944 category C2-Low, colour RAL 5010

Available options

- Braked motor (aluminium or cast iron)
- IP 56 TENV cast iron motor for marine applications
- 220 single-phase motors (up to 1.5 kW)
- Explosion-proof motors
- Protective steel motor cover
- Manual or remotely controlled disengaging clutch

- Alternative speeds
- Protective guards
- Marine / offshore coating systems

Available control options

- Direct pendant remote control IP 65 with emergency stop (up to 1.5 kW 220 V AC / 1-phase or 2.2 kW 400 V AC / 3-phases)
- Control box IP 55 with push-buttons and emergency stop built acc. to NEN 1010
- Control box IP 66 with low voltage IP 65 remote control built acc. to NEN 1010
- Load limiter
- Frequency inverter for variable speed control
- Wireless radio remote control systems
- Limit switches

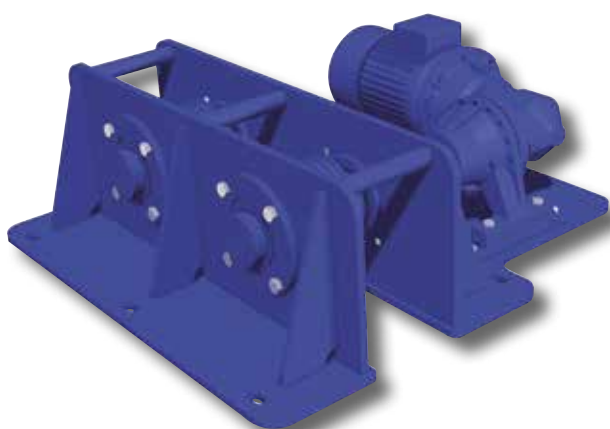

Planetary traction winch

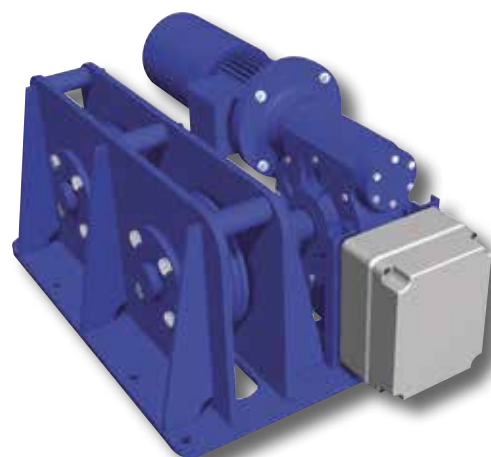

Wormgear traction winch

EMCÉ

WINCHES



Oil & Gas

Industry

Renewables

Marine



A range of compact lifting and pulling air winches specially designed for offshore applications or for any other hazardous environment where space is limited.

The heavy duty planetary gearbox is mounted within the drum core, which both saves space and protects from any external damage. Winches designed to meet independent third party requirements such as Lloyds, ABS, etc. These standard winches can be fitted with several options and accessories. Two of the winches are manriding prepared.

Standard features

- OAW: utility lifting
- OMR: manriding prepared
- OAW/OMR GP: contact less maintenance free gear motor including (biased) throttle valve
- Heavy duty planetary gearbox integrated in gearbox
- Exhaust silencing mufflers
- Cable fixing point at flange
- Two drum supports
- Standard temperature range -10° to +40°C
- Automatic disc brake
- Three layer 2-component conservation according ISO 12944 category C4-High, colour RAL 1023
- FEM / ISO class: T4-L3-M5
- Drum dividers
- Band brakes (manual or automatic failsafe)
- Manual disengaging clutches (only allowed for pulling applications)
- Spooling gears
- Grooved drums
- Manriding package
- Third party certification (LRS, ABS, etc)
- ATEX Certificate

Available control options

- Emergency main shut-off valves
- Load limiters
- Limit switches (pneumatic)
- Slack wire switches (pneumatic)
- Proportional remote control valve
- Air service units

Available options

- Marine / offshore coating systems
- Alternative drum lengths
- Drum pressure rollers
- Drum guards
- Drum locking pins

Winch type	WLL 1 st layer kg	WLL 5 th layer kg	Recomm. Rope diam. mm	Average speed* m/min.	Maximum speed** m/min.	Drumcap. 5 th layer m	Pressure drop in bar	Flow in l/sec.
OAW 1.5 GP4	1955	1500	12	9	14	178	7	100
OAW 2.0 GP4	2650	2000	13	6	10	167	7	100
OAW 2.5 GP6	3500	2500	16	10	14	144	7	200
OAW 2.5 GP10	3500	2500	16	19	36	144	7	300
OAW 2.5 GP16	3500	2500	16	30	67	144	7	350
OMR 1.5 GP10	2000	1500	13	30	54	171	6	300
OAW 3.5 GP10	4850	3500	18	14	26	181	7	300
OAW 3.5 GP16	4850	3500	18	21	46	181	7	350
OAW 5.0 GP10	6800	5000	19	10	19	212	7	300
OAW 5.0 GP16	6800	5000	19	15	36	212	7	350
OMR 3.0 GP10	4280	3150	19	14	25	212	6	300
OAW 6.5 GP10	9180	6500	22	7	14	209	7	300
OAW 6.5 GP16	9180	6500	22	12	28	209	7	350
OAW 7.0 GP16	9885	7000	22	10	22	209	7	350
OAW 8.5 GP16	12160	8500	26	8.5	20	228	7	350
OAW 10.5 GP16	14890	10500	28	7	16	244	7	350

* Average speed is based on the speed in the middle layer at 75% of WLL

** Maximum speed is based on the speed in the top layer at unloaded conditions

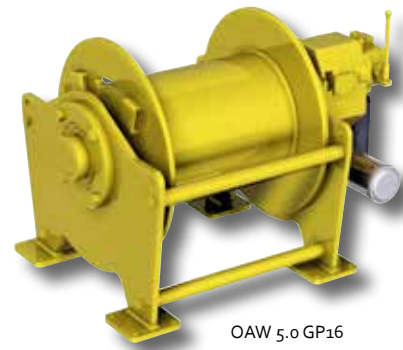
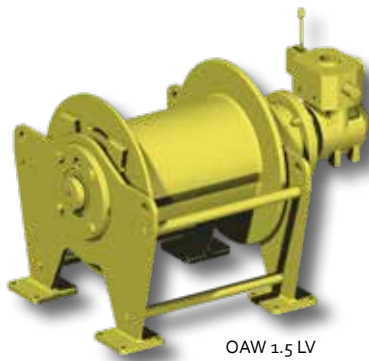
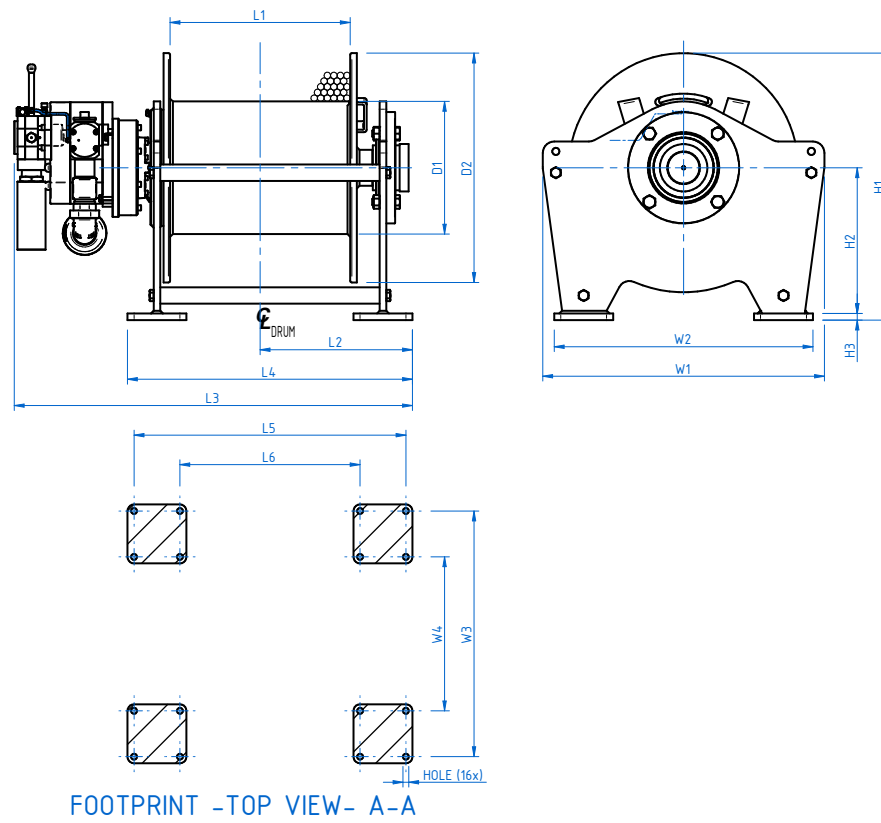

Type	Mass kg	D1	D2	L1	L2	L3 (GP)	L4	L5	L6	H1	H2	H3	W1	W2	W3	W4	HOLE
OAW 1.5	355	305	500	400	322	876	625	595	375	650	345	15	660	550	520	300	14
OAW 2.0	420	305	500	400	360	930	680	640	400	615	345	20	660	570	530	290	14
OAW 2.5	665	305	550	410	375	1092	700	660	420	665	370	20	710	620	580	340	14
OMR 1.5	705	305	550	410	375	1202	810	770	530	665	370	20	850	620	580	340	14
OAW 3.5	840	355	700	500	430	1169	810	770	490	815	445	20	860	790	750	470	18
OAW 5.0	820	405	700	550	465	1216	870	830	550	815	445	20	860	790	750	470	18
OMR 3.0	860	405	700	550	465	1326	980	940	660	815	445	20	1000	790	750	470	18
OAW 6.5	1180	405	750	610	528	1333	980	930	630	870	470	25	950	860	810	510	26
OAW 7.0	1185	405	750	610	528	1353	980	930	630	870	470	25	950	860	810	510	26
OAW 8.5	1270	455	850	690	582	1452	1075	1025	725	970	520	25	1050	960	910	610	26
OAW 10.5	1585	508	950	720	623	1545	1140	1090	750	1070	570	25	1150	1080	1030	690	26

A range of ultra compact lifting and pulling hydraulically driven winches specially designed for offshore applications or for any other hazardous environment where space is limited. The heavy duty planetary gearbox and brake are mounted within the drum core, which both saves space and protects from any external damage. Winches designed to meet independent third party requirements such as Lloyds, ABS, DNV, etc. These standard winches can be fitted with several options and accessories. The winches are manriding prepared. Adding specific options and reducing the WLL means that the winch can be used for manriding applications too. Winches are supplied without a control valve as standard, however, they do have a single acting shuttle valve.

Standard features

- OHW: utility lifting
- OHR: manriding prepared
- Heavy duty integrated planetary gearbox integrated.
- Fixed displacement axial tapered piston motor (Rexroth A2FE series)
- Steel drum, length 610 mm with cable fixing point at flange
- Two drum supports
- Standard temperature range -10° to 50°C.
- Oil bath disc brake
- Lifting lugs
- Three layer 2-component conservation according ISO 12944 category C4-High, colour RAL 1023
- FEM / ISO class: T4-L3-M5

- Drum pressure rollers
- Drum locking pins
- Band brakes (manual or automatic fail-safe)
- Drum guards
- Drum dividers
- Spooling gears
- Grooved drums
- Tubular offshore frame construction
- Manriding package

Available control options

- Proportional control valves
- Load limiters
- Limit switches (electric)
- Slack wire switches (electric)
- Proportional remote control valve
- HPU's

Available options

- Marine / offshore coating systems
- Alternative drum lengths

Winch type	WLL 1 st layer kg	WLL 5 th layer kg	Recomm. Rope diam. mm	Speed 5 th layer m/min.	Drumcap. 5 th layer m	Pressure drop in bar	Flow in l/min.
OHW2.5	3440	2500	16	44	225	205	85
OHR1.5	2000	1500	13	44	265	170	65
OHW4.5	6330	4500	19	38	210	230	120
OHR3.0	4400	3150	19	38	210	175	120
OHW5.0	7030	5000	19	28	210	195	120
OHW6.5	9170	6500	22	24	208	215	120
OHW7.0	9880	7000	22	24	208	225	120
OHW8.5	11800	8500	25	24	226	265	120
OHW10.5	14300	10500	29	20	231	225	150
OHW11.5	16090	11500	32	20	214	250	145
OHW16	23140	16000	36	16	193	250	160
OHW20	28115	20000	38	14	210	295	165

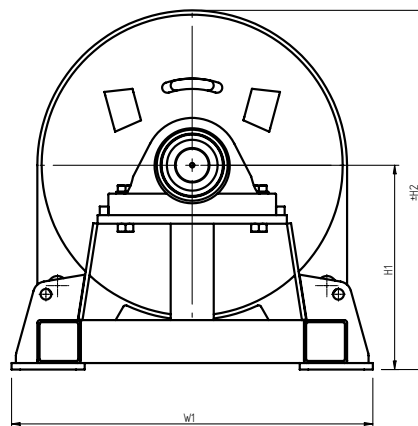
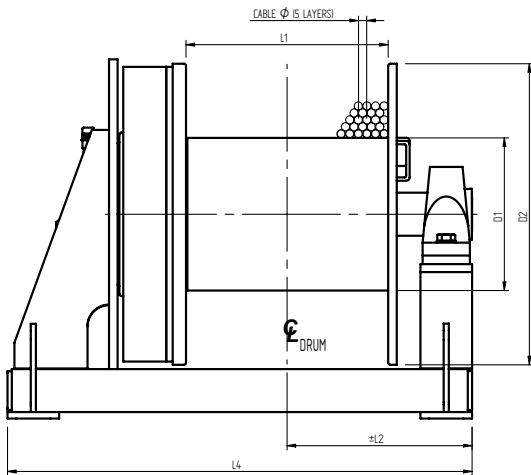
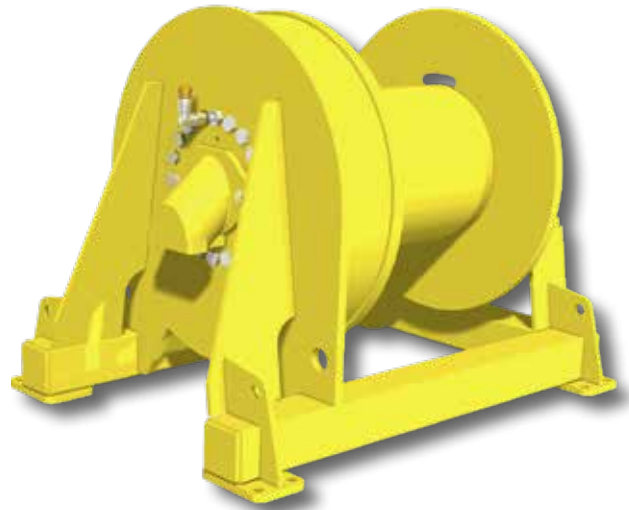
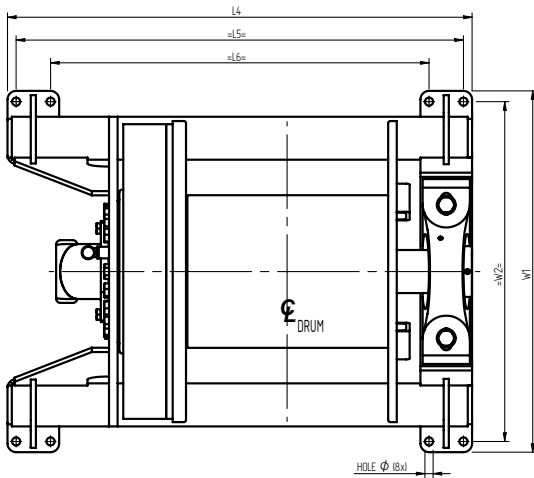

Oil & Gas

Type	Mass kg	D1	D2	L1	L2	L4	L5	L6	H1	H2	W1	W2	Hole
OHW 2.5	365	323	550	610	470	1120	1060	940	395	675	700	660	14
OHR 1.5	395	323	550	610	470	1120	1060	940	395	675	700	660	14
OHW 4.5	735	355	700	610	500	1220	1180	1020	470	820	840	790	19
OHW 5.0	735	355	700	610	500	1220	1180	1020	470	820	840	790	19
OHR 3.0	765	355	700	610	500	1220	1180	1020	470	820	840	790	19
OHW 6.5	940	406	750	610	535	1320	1260	1100	540	915	1000	940	22
OHW 7.0	940	406	750	610	535	1320	1260	1100	540	915	1000	940	22
OHW 8.5	1360	508	900	610	539	1370	1300	1100	625	1090	1120	1050	26
OHW 10.5	1600	609	1010	610	539	1380	1310	1110	680	1205	1220	1150	26
OHW 11.5	1600	609	1010	610	539	1380	1310	1110	680	1205	1220	1150	26
OHW 16	2450	609	1150	610	539	1600	1520	1240	720	1300	1450	1380	36
OHW 20	2600	711	1250	610	550	1600	1530	1330	800	1400	1600	1520	36

Designed to the standards issued by the classification bodies and it meets the UK HSE regulations for personnel lifting operations on offshore installations. The winches are dedicated personnel lifting winches supplied with full material traceability. They have passed EC testing for these applications, i.e., both the winches and their technical files are in compliance with the requirements of the EC Machinery Directives.

The MR 30 FL winches have been specially designed for personnel lifting applications in which a safety harness or a boatswain's chair is used on fixed installations with a total WLL of 150 kg.

The MR 30 FGL winches have passed EC testing for these applications, i.e., both the winches can be supplied with a Lloyds Register of Shipping (LRS), ABS or DNV Design Appraisal Certificate.

The MR 50 FL and MR 60 FL have been designed for use with assemblies using a platform, basket, carrier, etc, with a total WLL of 500 kg for the MR 50 FL and 1000 kg for the MR 60 FL.

Standard features

- Helical shaft mounted gearbox, life lubricated with synthetic oil
- UK HSE compliance
- Caliper primary brake 180% of WLL
- Automatic band brake as secondary drum acting brake 180% of WLL
- Pneumatic gearmotor
- Orbit hydraulic motor
- Helical grooved steel drum
- Full material traceability (3.1 - EN 10204) on load-bearing parts
- Two drum supports
- Limit switch
- Slack wire switch
- Overload protection device
- Local proportional control with biased control valve (pneumatic models only)
- Local proportional control with biased control valve (MR 30 FLP/FLV only)
- Drum guard
- Mufflers (on MR 30), 50 en 60 FLG

- Air service unit (pneumatic models only)
- Main air emergency stop valve
- Operating conditions -20°C to 50°C
- Three layer 2-component conservation according ISO 12944 category C4-High, colour RAL 1023
- FEM / ISO class: T4-L3-M5
- Emergency lowering accumulator
- ABS PDA approved

Available options

- Electric versions
- Alternative speeds
- Alternative drum dimensions
- Operating conditions -45°C to 50°C

Available control options

- Electric/hydraulic or pneumatic control systems
- Pneumatic pendant remote control on portable pedestal
- Pneumatic pendant remote control with shoulder harness

Winch type	W.L.L 1 st layer kg	WLL top layer kg	Recomm. Rope diam. mm	Speed top layer m/min.	Drumcap. top layer m	Pressure drop in bar	Flow in l/sec.	Flow in l/min.
MR30FLG	200	150 (5)	10	37	165	6	50	
MR50FLG	635	500 (4)	13	16	135	7	65	
MR60FLG	1270	1000 (4)	13	30	135	6.5	120	
MR30FLH	200	150 (5)	10	43	150	70		25

* The pressure roller and slack wire switch are optional items for the MR 50 FLG and MR 60 FLG

* The spindle limit switch and slack wire switch on the MR 30 FLH are electric switches (intrinsically safe)

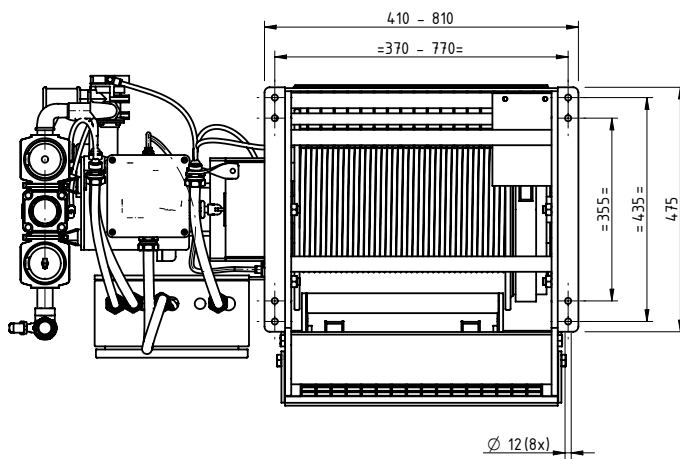
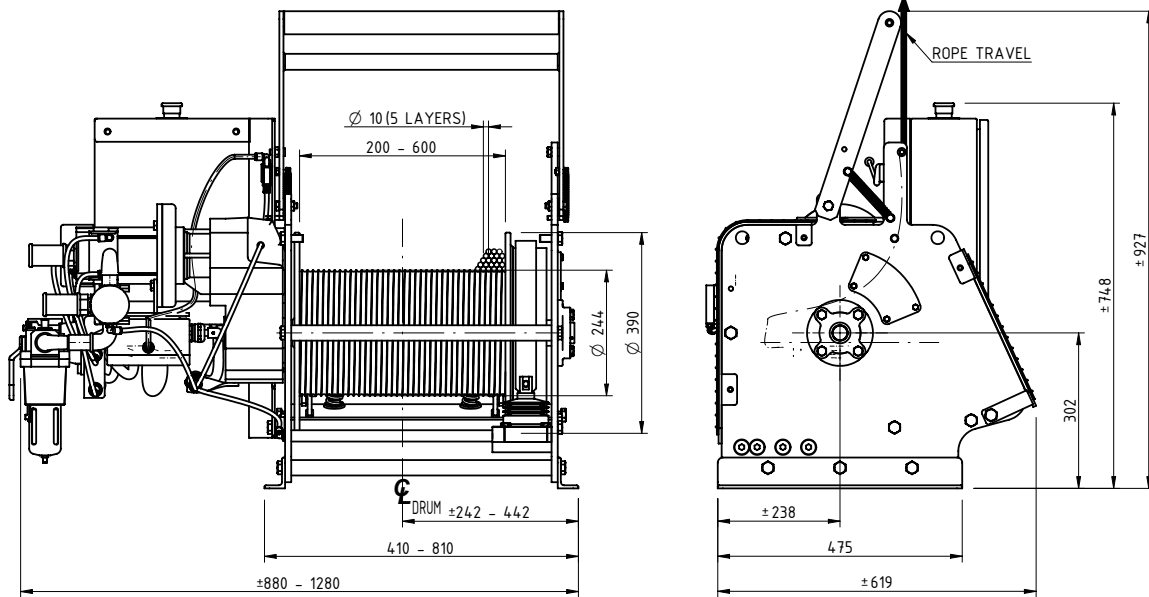

Drawing for MR 30 FLG only

Others upon request

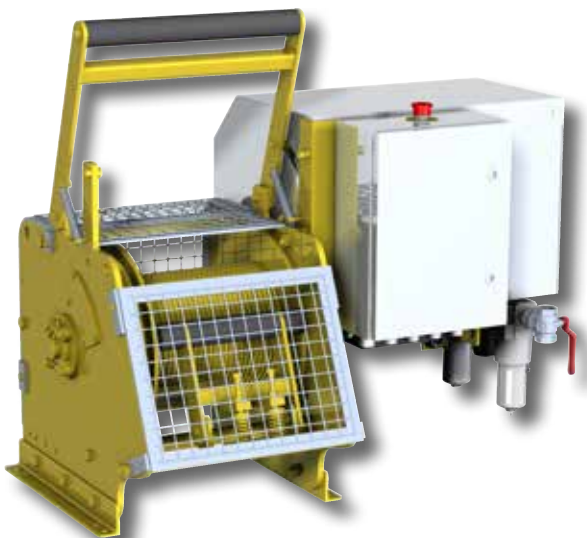

MR 30 FLG
Weight: ~300 kg

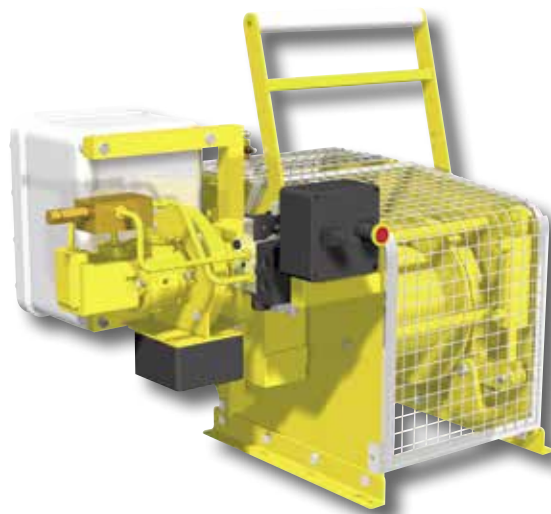

MR 30 FLH
Weight: ~340 kg

A range of standard pneumatic winches with high efficiency gearbox, developed for heavy duty pulling and lifting duties up to 2,700 kg. This broad range comprises a variation of very compact winches with vane or gear motors. Drum lengths can easily be adapted to the customers request.

Standard features

- High efficiency transmission
- A series: right angle helical gearbox
- F series: in line helical gearbox
- A/F LV: Rotary vane motor
- A/F GP: Contact less maintenance free gear motor
- Steel drum (not grooved) with cable fixing point at flange
- Two drum supports
- Three layer 2-component conservation according ISO 12944 category C4-High, colour RAL 1023
- Automatic disc brake
- Lever operated proportional control valve
- FEM / ISO class: T3-L3-M4

Available options

- Offshore three layer 2 component conservation
- Alternative drum lengths
- Drum pressure rollers
- Band brakes (manual or automatic failsafe)
- Manual disengaging clutches
- Drum guards
- Drum dividers
- Spooling gears
- Grooved drums

Available control options

- Emergency main shut off valves
- Load limiters
- Limit switches (pneumatic)
- Slack wire switches (pneumatic)
- Proportional remote control valve
- Air service units

Winch type pneumatic	WLL 1 st layer kg	WLL 5 th layer kg	Average speed* m/min.	Maxium speed* m/min.	Recomm. rope diam. mm	Drumcap. 1 st layer m	Drumcap. 5 th layer m	Pressure drop bar	flow in l/sec.
A 20 GP2	500	345	25	38	6	7	48	7	65
A 30 GP2	650	435	21	32	8	6	44	7	65
A 35 GP2	900	600	15	23	8	6	44	7	65
A 41 GP2	1200	820	11	17	9	10	62	7	65
A 50 GP2	1800	1205	8	12	11	10	74	7	65
A 55 GP4	2200	1460	11	14	12	9	72	7	100
A 60 GP4	2700	1800	9	11	14	17	117	7	100

Winch type pneumatic	WLL 1 st layer kg	WLL top layer kg	Average speed* m/min.	Maxium speed* m/min.	Recomm. rope diam. mm	Drumcap. 1 st layer m	Drumcap. top layer m	Pressure drop bar	flow in l/sec.
F 20 GP2	500	345 (5)	25	38	6	12	80 (5)	7	65
F 25 GP2	650	435 (5)	21	32	8	10	74 (5)	7	65
F 31 GP2	900	600 (5)	15	23	8	10	74 (5)	7	65
F 41 GP2	1350	1000 (4)	9	16	10	13	70 (4)	7	65
F 51 GP4	2000	1450 (4)	12	15	12	17	88 (4)	7	100
F 60 GP4	2700	1965 (4)	9	11	14	22	111 (4)	7	100

* Average speed is based on the speed in the middle layer at 75% of WLL
 ** Maxium speed is based on the speed in the top layer at unloaded conditions

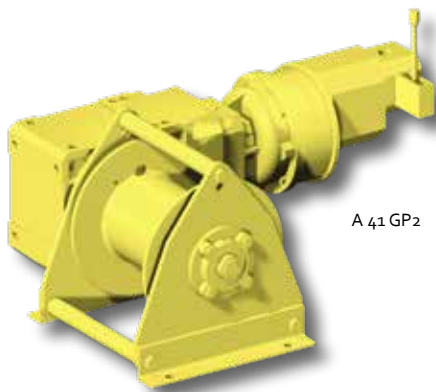

A 41 GP2

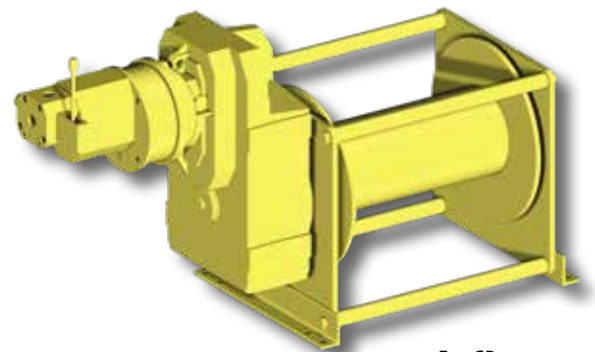
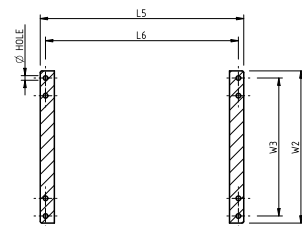
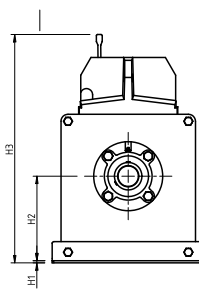
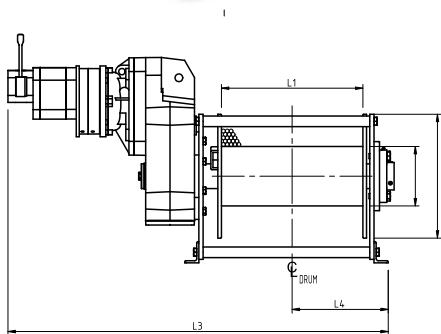
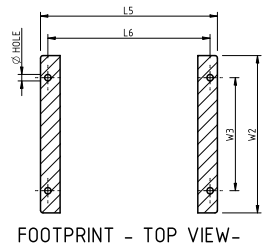
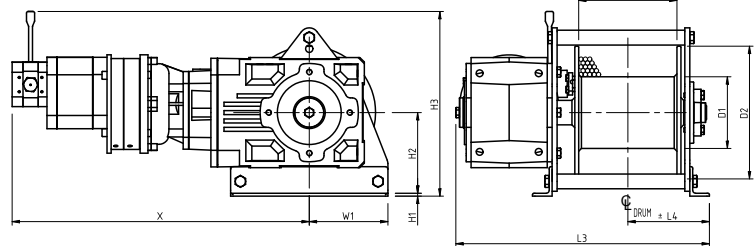

F 51 GP4

Winch type	Mass (kg)	D1	D2	L1	L2	L3	L4	L5	L6	H1	H2	H3	W1	W2	W3	Hole Ø	X (LV)	X (GP)
A 20	60	100	175	150	103	430	139	305	275	6	164	342	160	320	230	13 (4x)	545	505
A 30	75	121	225	150	129	445	141	310	280	6	164	342	160	320	230	13 (4x)	565	525
A 35	90	121	225	150	134	455	141	310	280	6	164	342	160	320	230	13 (4x)	570	530
A 41	115	146	270	200	141	516	166	360	330	6	164	342	160	320	230	13 (4x)	645	605
A 50	190	168	350	250	168	620	198	425	395	6	239	420	215	430	390	13 (8x)	705	665
A 55	220	178	350	250	168	645	198	425	395	6	239	420	215	430	390	13 (8x)	795	705
A 60	255	210	390	400	180	790	270	575	545	6	239	440	235	470	430	13 (8x)	805	715
Winch type	Mass (kg)	D1	D2	L1	L2	L3 (LV)	L3 (GP)	L4	L5	L6	H1	H2	H3 (LV)	H3 (GP)	W2	W3	Hole Ø	
F 20	65	100	175	250	405	885	845	189	405	375	6	164	540	440	320	230	13 (4x)	
F 25	80	121	225	250	410	905	865	191	410	380	6	164	545	445	320	230	13 (4x)	
F 31	95	121	225	250	410	915	875	191	410	380	6	164	565	465	320	230	13 (4x)	
F 41	125	159	270	300	460	985	945	216	460	430	6	164	590	490	320	230	13 (4x)	
F 50	220	178	350	400	575	1125	1085	273	575	545	6	239	700	600	430	390	13 (8x)	
F 60	290	210	390	500	675	1255	1215	320	675	645	6	239	760	660	470	430	13 (8x)	

This standard range of the SRM type mooring/anchor winches is designed for application on jack-up rigs, barges and other offshore or marine units. These standard winches can be fitted with several options such as free spooling clutches and spooling gears. Also a range of mooring accessories can be offered with these winches such as fairleads, sheaves, wire rope and load measuring equipment. Winches will be subject to our standard internal test procedure, which can be witnessed by the client and/or third party.

Standard winch features

- Heavy duty slew ring
- Heavy duty planetary gearboxes fitted with pinions
- SRM E; IP 56 TENV seawater-resistant 400 - 440 V AC / 3-phases / 50 - 60 Hz braked motors.
- SRM H; radial piston type hydraulic motors complete with brake valve
- Steel drum with cable fixing point at flange
- Band brake (manual)
- Two drum supports
- Lifting lugs
- Three layer 2-component conservation according ISO 12944 category C4-High, colour RAL 1023
- FEM / ISO class: T3-L3-M4

Available control options

- Control box IP 55 with push-buttons and emergency stop
- Control box IP 66 with low voltage IP 65 remote control
- Load limiter
- Frequency inverter for variable speed control
- Load and/or line monitoring
- Proportional local or remote control valve (pneumatic or hydraulic)

Available mooring equipment

- Horizontal deck sheaves without or with load pins
- Swivel fairleads
- 4, 6, 7 or 10 roller fairleads
- Deck bollards and chocks

Available winch options

- Automatic band brakes
- Alternative speeds
- Alternative supply voltages
- Drum guards
- Spooling gears
- Grooved drums
- Alternative drum dimensions / rope lengths / rope diameters
- Warping head
- Wire rope

Winch type	WLL 1 ST layer kg	WLL 7 TH layer kg	Recomm. rope diam. mm	Speed 1 ST layer m/min.	Speed 7 TH layer m/min.	Drumcap. 7 TH layer m	Bandbrake holdingforce 1 ST layer / kg	Pressure drop in bar	Flow in l/min.	Motor power kW
SRM 18 E1	18000	11265	32	8.5	13.5	430	45000			30
SRM 25 E2	25000	14980	36	8.5	14	390	62500			44
SRM 30 E2	30000	17610	38	7	12	375	75000			44
SRM 36 E2	36000	22265	44	7.5	12	415	90000			60
SRM 18 H1	18000	11265	32	8	13	430	45000	220	120	
SRM 25 H2	25000	14980	36	11	18	390	62500	230	210	
SRM 30 H2	30000	17610	38	10	17	375	75000	220	240	
SRM 36 H2	36000	22265	44	8.5	14	415	90000	230	240	

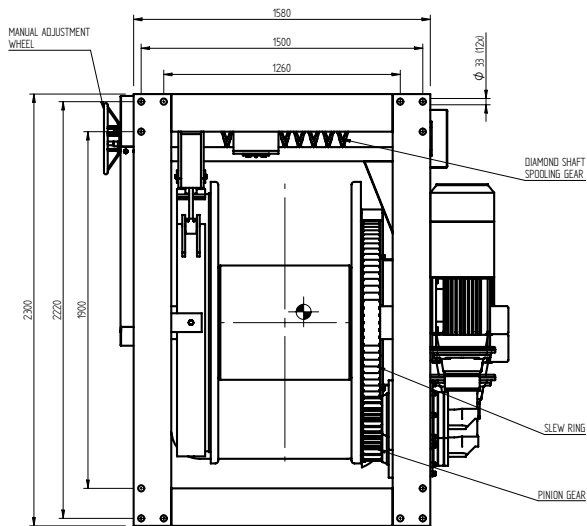
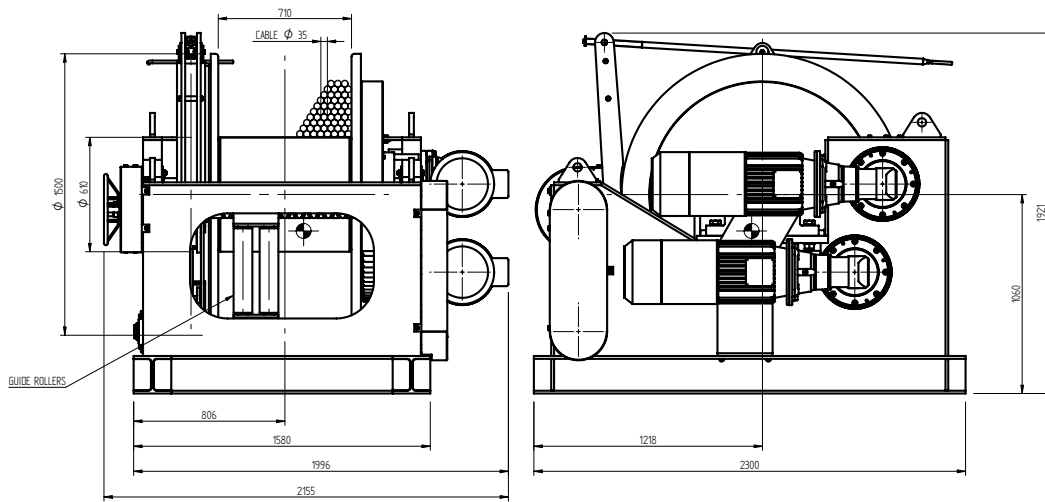

Drawing for
SRM 25 E2 only

Others upon
request

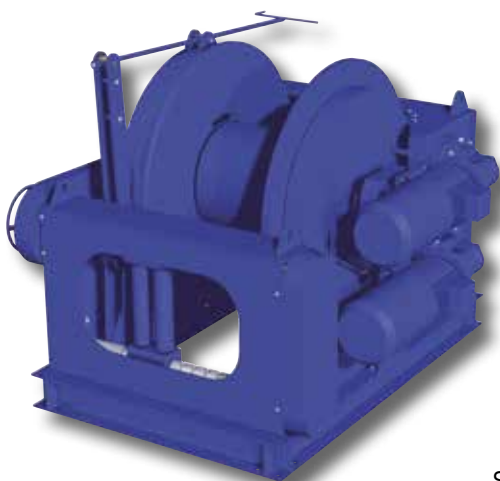

SRM 25 E2

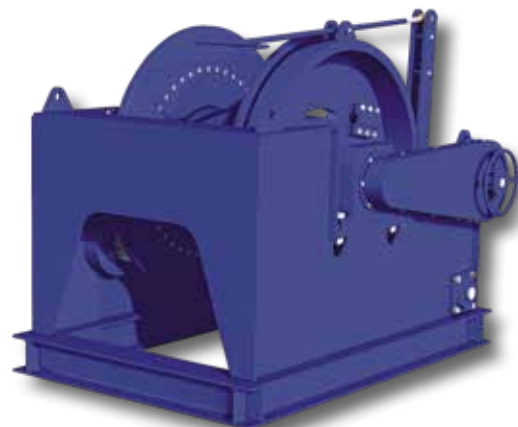

EMCÉ
WINCHES



Renewables

Industry

Oil & Gas

Marine



Winches for Renewable power sources

Renewables cover a wide spectrum of technologies, ranging from PV, hydro energy, wind and tidal generator systems. Constructing these power generating plants, EMCÉ lifting and positioning equipment plays an important role. In some applications EMCÉ winches are even a crucial part of the system itself as in kite driven generator systems or auxiliary propulsion kite systems for shipping applications. In most cases however the EMCÉ equipment is used for construction, installation and maintenance purposes. For some specific tasks, such as for cable pull up duties, the winches or capstans are available with special capabilities:

Typical applications

- Lifting equipment for construction of wind turbines
- Tool hoists for wind turbine applications
- Generator kite winches
- Ship pulling kite winches
- Positioning winches for tidal energy barges
- Man riding inspection winches for hydro powerplant supply tubes
- DNVGL-ST E272 Hose reels for sea water driven pile driving equipment for wind turbine foundation
- Cable pull-in winches for pulling off shore wind turbine cables (inter-array/export)
- Safety door winches for hydro power plants

Specific options

- Very accurate load measuring by means of a single load-shackle
- Load data storage value-date-time
- Data port for interface with client monitoring system
- Completely enclosed outer frame with insulated panels and heating inside for long term preservation in hostile environments
- Knock Down versions offering < 1000 kg single component weight for critical lifting or floor loading transport situations.
- Spooling gear for proper rope spooling with extreme fleet angles
- Rope speed and length measurement
- Double drum selections for steel and HMPE if required
- Remote control with HMI panel
- Suitable for use of HMPE rope
- Delivery with cable or rope pre-tensioned onto the drum

The winches and capstans in our “Renewables” series possess the same standard features of our Oil & Gas winches, and can also be executed with the same mechanical and control options.

SC cable Pull In winches

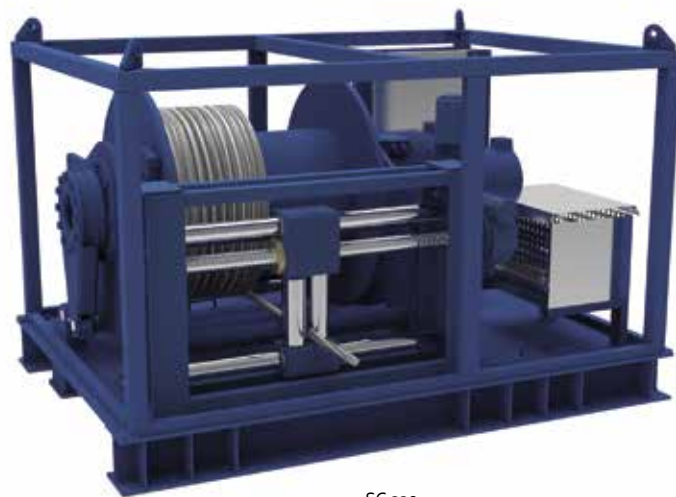

SC 220

Winch type Electric	WLL 1 ST layer kg	WLL 6 TH layer kg	Recomm. rope diam. mm	Speed 1 ST layer m/min.	Speed 6 TH layer m/min.	Drumcap. 1 ST layer m	Drumcap. 6 ST layer m	Motor power kW	Dimensions LxWxH mm	Weight kg
SC-10PI	15000	10000	26	5	8	35	250	15	2250 x 1750 x 1650	4700
SC-15PI	22000	15000	30	5	8	40	300	22	2500 x 1800 x 1750	5200
SC-20PI	30000	20000	34	5	8	40	300	30	2600 x 2000 x 1850	6000
SC-25PI	38000	25000	38	5	8	50	350	37	2800 x 2000 x 2000	6500
SC-30PI	44000	30000	40	5	7	50	350	45	2800 x 2300 x 2100	7500



EMCÉ
WINCHES

Marine

Industry

Oil & Gas

Renewables



AW winches are designed to position and hold accommodation and ship-to-shore ladders and ladders between vessels and offshore installations.

Constructed in accordance with ISO 7364 requirements for international shipping, the range features a dynamically and statically self-braking wormgear and emergency hand crank. Each type may be configured for single or twin rope operation and powered by means of an electric or pneumatic motor.

PW winches are used to lower and lift the pilot ladder on board of seagoing vessels, EMCE has one standard design, PW 550, that has been supplied to several dredging vessel fleet owners. We have also supplied custom-built designs. Please ask about the available options.

Standard features

- Self-braking wormgear transmission for the AW series
- Planetary gear for PW 550
- ISO 7364 compliance
- IP 56 TENV motor protection for the AW ES series
- IP 66 TENV with standstill heating for the PW 550
- Rotary vane, gear type air or motor for the AW LS series
- Steel drum (not grooved) with one or two cable fixing point(s) at flange
- Two drum supports
- Emergency hand crank for the AW series only
- Double layer 2-component conservation, colour RAL 5010
- 13 meter pilot ladder with 32 flat steps, 4 spreaders and 4 rubber steps for PW 550
- Pneumatic versions with hand control valve
- IP 66 spindle limit switch for PW 550
- FEM / ISO class: T3-L3-M4

Available options

- Band brake, manual or automatic fail-safe for the AW series
- Increased motor protection IP 68 TENV for the AW series
- Alternative supply voltages
- Grooved drum for AW series only
- Drum pressure roller for AW series only
- Alternative speeds
- Alternative drum dimensions / split drums / additional rope anchors / etc.
- Drum guard for AW series only
- Marine / offshore coating systems
- Class witness certificates

Available control options

- Electric or pneumatic control systems
- Limit switches
- Load limiters

Winch type	WLL kg	Holding Force kg	Recomm. Rope diam. mm.	Speed 1 st layer m/min.	Drumcap. 3 rd layer m	Motor power 400 VAC kW	Pressure Drop bar	Flow in l/sec.
AW 500 ES	500	1500	8	6	30	1.5		
	2 X 250	1500	6	6	2 X 18	1.5		
AW 1000 ES	1000	3000	10	7.5	40	3		
	2 X 500	3000	8	7.5	2 X 23	3		
AW 1500 ES	1500	4000	12	9.5	50	5.5		
	2 X 750	4000	10	9.5	2 X 27	5.5		
AW 500 LS	500	1500	8	6	30		6	60
	2 X 250	1500	6	6	2 X 18		6	60
AW 1000 LS	1000	3000	10	6.5	40		6	100
	2 X 500	3000	8	6.5	2 X 23		6	100
AW 1500 LS	1500	4000	12	7.5	50		6	130
	2 X 750	4000	10	7.5	2 X 27		6	130
PW 550 E	550	2000		12	13 m ladder	1.1		

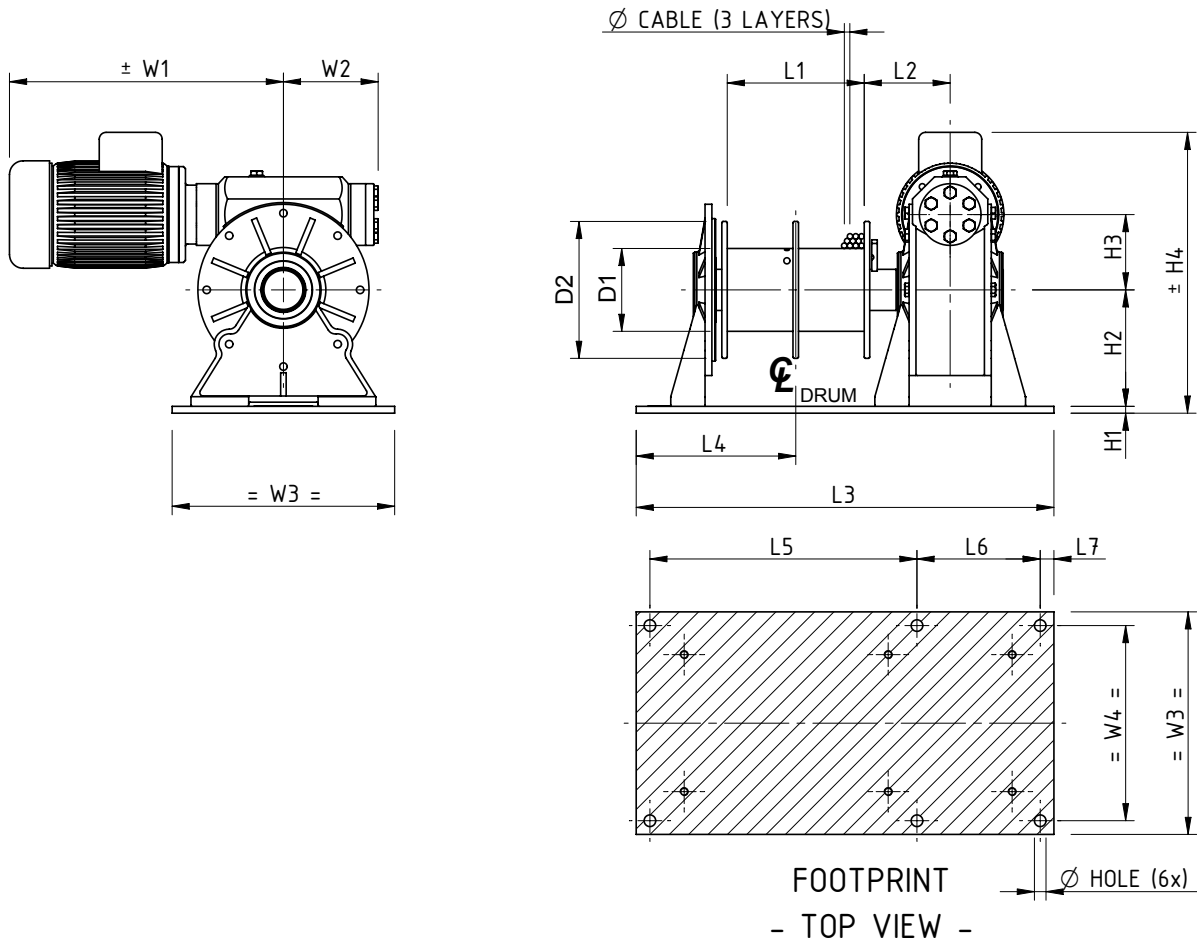

AW 500-1500

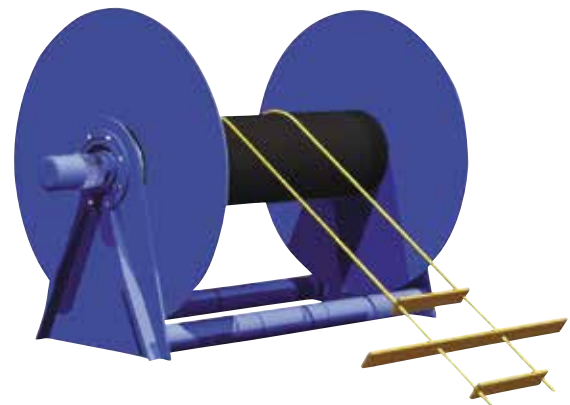

PW 550

Type	Mass (kg)	D1	D2	L1	L2	L3	L4	L5	L6	L7	H1	H2	H3	H4	W1	W2	W3	W4	Hole \varnothing
AW 500	85	121	250	200	125.5	610	228	390	180	20	10	170	110	410	400	140	325	285	17
AW 1000	195	159	320	250	155	710	260	470	200	20	15	220	150	522	519	154	410	360	17
AW 1500	275	195	370	300	180	850	318	565	235	25	15	254	182	570.5	546	207	440	380	20
PW 550	1600	508	1700	1900	218	2440	1193	2552	-	-	-	1080	-	1930	650	250	-	-	-

Wormgear capstans

Self-braking worm gear drives with electric, hydraulic or even pneumatic motor, available in on-deck or below-deck build types. The on-deck drive is equipped with a waterproof motor for intermittent use. The below-deck drive is equipped with a dripwater-proof motor and a mounting plate with an extra self aligning bearing suitable for high static loads such as with mooring ropes. Pneumatic drives are available upon request.

Planetary capstans

Featuring a cast iron capstan head mounted on a heavy duty planetary gearbox. The entire drive is mounted in a watertight tube frame providing optimal protection from the elements. Pneumatic drives are available upon request. Capstans up to 20 tons can be offered upon request.

Standard features

- Heavy duty wormgear or planetary gearbox
- IP 54 braked motor 400 VAC / 3-phases / 50 Hz for planetary capstans
- IP 56 TENV cast iron 400 V AC / 3-phase / 50 Hz non-braked motor for on-deck wormgear capstans
- IP 54 400 V AC / 3 phases / 50 Hz non-braked motor for under-deck wormgear capstans
- Single speed and one direction only (electric capstans only)
- Orbit or radial piston type hydraulic motor
- Vertical cast iron warping head according to ISO 6482
- Three layer 2-component conservation according ISO 12944 category C4-High, colour RAL 5010

Available options

- Cast iron motor for planetary capstans
- Explosion proof motors
- Back stop bearing build in planetary gearbox for one direction (replaces brake)
- 2 speed motors
- Alternative speeds
- Alternative supply voltages
- Horizontal warping head configuration
- Marine / offshore coating systems

Available control options

- Control box IP 55 with IP 65 foot pedal (single speed, one direction) control built acc. to NEN 1010
- Control box IP 66 with IP 66 foot pedal (two speed, two directions) control built acc. to NEN 1010
- Frequency inverter and proportional foot pedal for variable speed control
- Proportional local or remote control valve (pneumatic or hydraulic)
- Pneumatic drive

Winch type Worm	WLL kg	Speed m/min	Neck diameter mm	Max. rope diam. mm	Motor power 400 V kW	Pressure drop in bar	Flow in l/min.
C 086 E	500	6	100	16	1.1		
C 110 E	700	11	140	22	2.2		
C 130 E	1100	9	140	22	3		
C 150 E	1300	13	195	30	5.5		
C 185 E	1700	10	195	30	5.5		
C 086 H	500	8	100	16		70	20
C 110 H	700	8	140	22		105	15
C 130 H	1100	7	140	22		60	40
C 150 H	1300	10	195	30		90	40
C 185 H	1800	10	195	30		90	60

Winch type Planetary	WLL continuous kg	Speed m/min.	Neck diameter mm	Recomm. rope diam. mm	Motor power 400 V Kw	Pressure Drop in Bar	Flow in l/min.
C 300 E	1000	12	195	30	2.2		
C301 E	1650	10	195	30	3		
C 303 E	2300	10	195	30	4		
C 305 E	3400	9	275	35	5.5		
C 306 E	4900	10	275	46	7.5		
C 307 E	5500	11	405	52	11		
C 309 E	7500	11	405	52	15		
C 310 E	10000	8	450	75	15		
C 300 H	1000	30	195	30		105	60
C 301 H	1650	28	195	30		135	60
C 303 H	2600	18	195	30		140	60
C 305 H	4000	17	275	35		165	70
C 307 H	6000	25	405	52		220	105
C 309 H	7500	20	405	52		205	120
C 310 H	10000	17	450	75		230	120

C 086 - C 185
on deck

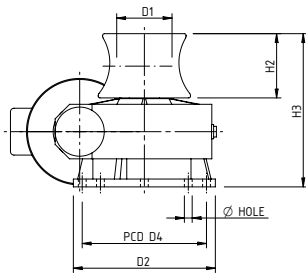

C 086 - C 185
below deck

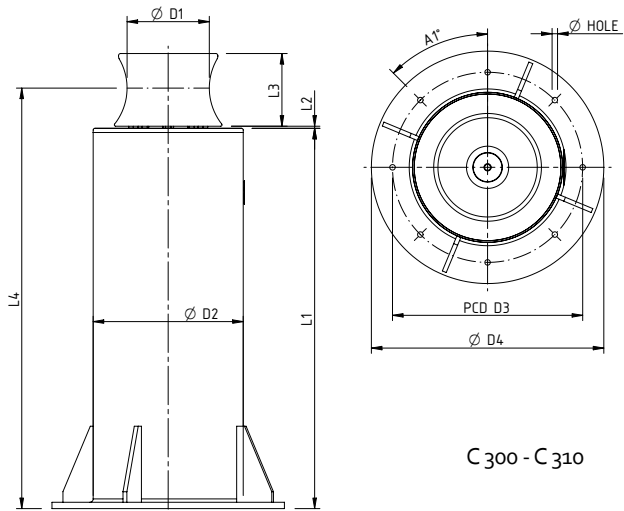
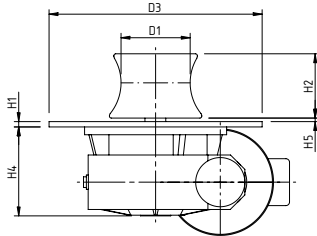

C 300 - C 310

Type	Mass (kg)	D1	D2	D3	D4	H1	H2	H3	H4	H5	Hole
C 086	50	100	210	300	176	10	130	320	190	10	8x 12.5
C 110	70	140	280	390	230	10	130	350	209	10	8x 13.5
C 130	90	140	320	420	255	15	130	360	230	10	8x 16
C 150	130	195	350	450	290	15	180	415	245	10	8x 18
C 185	170	195	400	500	350	15	180	440	251	10	8x 22
Type	Mass (kg)	D1	D2	D3	D4	L1	L2	L3	L4	A1	Hole
C 300	225	195	355	450	550	900	5	181	1004	8x 45	13
C 301	225	195	355	450	550	900	5	181	1004	8x 45	13
C 303	275	195	406	500	600	1000	5	181	1104	12x 30	18
C 305	405	275	455	570	650	1100	5	255	1246	12x 30	18
C 306	450	275	455	570	650	1100	5	255	1246	12x 30	18
C 307	870	405	610	700	800	1300	5	320	1487	12x 30	18
C 309	930	405	610	720	825	1300	5	320	1487	12x 30	22
C 310	1095	450	711	840	950	1350	5	500	1636	10x 36	27

This series of windlasses has been especially designed for intensive use and therefore has a robust construction. All windlasses are designed with a self-braking gearbox (except P 1000 H and P 1600 H) which will save the costs of an expensive brake motor.

The band brakes are lined with a ferrodo (non-asbestos) friction material.

Standard features

- Heavy duty worm gearbox or planetary/ worm gear combination
- IP 56 TENV cast iron 400 V AC / 3 phases / 50 Hz non-braking motor with torque knob
- Orbit type hydraulic motor
- Suitable for 10 – 28 mm DIN / Studlink chain sizes from 12.5 – 28 mm
- Free-fall clutch
- Band brake
- Horizontal cast iron warping head
- Three layer 2-component conservation according ISO 12944 category C4-High, colour RAL 5010

Available options

- Double executions possible for W 120 up to W 600
- Alternative supply voltages
- Full manual control by means of hand wheel
- Horizontal warping head configuration
- Remotely controlled band brakes
- Classification certificate from any recognised marine classification body
- Special marine / offshore coating systems

Available control options

- IP 66 control box with IP 65 pendant remote control or push-buttons built acc. to NEN 1010
- Proportional local or remote control valve

Winch type	Chain pull kg	Chain size din	Chain size stud	Speed m/min.	Bandbrake holding force kg	Motor power 400 V kW S2	Peak power 400 V kW
W 120 E	400	10		10	1200	1.1	1.5
W 150 E	600	10-13		10	1500	1.5	2.2
W 250 E	750	13-16	14	10	2500	2.2	3
W 350 E	1200	16	16	10	3500	4	5.5
W 400 E	1200	16	16	10	4000	4	5.5
W 600 E	2000	16-18	16	10	6000	5.5	7.5
PW 1000 E	3600	20	19	10	10000	7.5	11
PW 1600 E	5500	22	22	10	16000	15	18.5
Winch type	Chain pull kg	Chain size din	Chain size stud	Speed m/min.	Bandbrake holding force kg	Pressure drop in bar	Flow in l/min.
W 120 H	400	10		10	1200	70	20
W 150 H	600	10-13		10	1500	100	20
W 250 H	750	13-16	14	10	2500	60	40
W 350 H	1200	16	16	10	3500	95	40
W 400 H	1200	16	16	10	4000	95	40
W 600 H	2000	16-18	16	10	6000	100	60
P 1000 H	3600	20	19	10	10000	95	55
P 1600 H	5500	22	22	10	16000	120	60

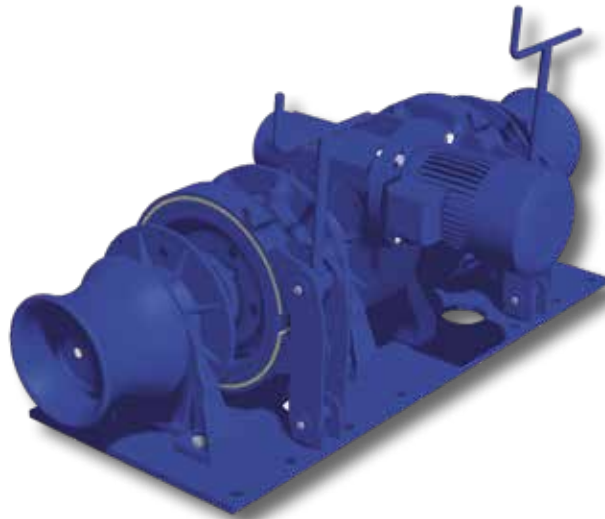
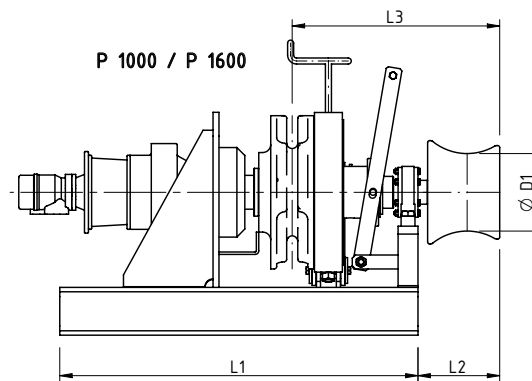
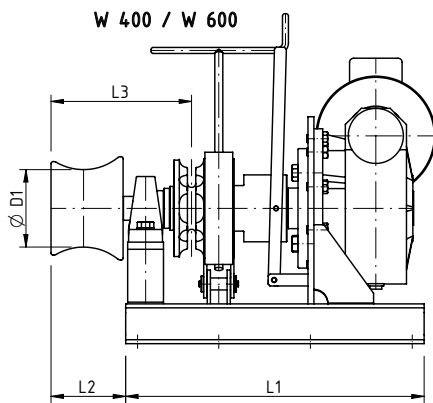
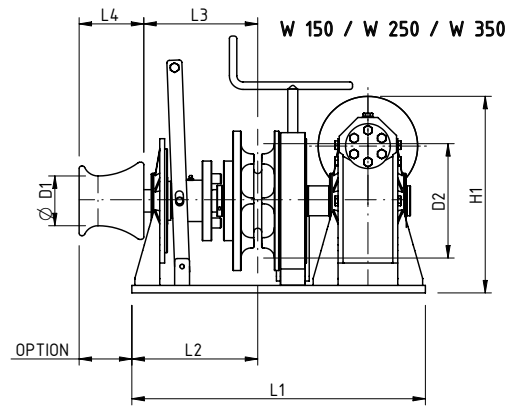
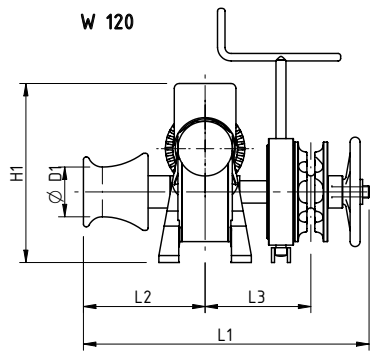

Type	Mass (kg)	D1	D2	L1	L2	L3	L4	H1
W 120	63	100	180	590	255	245	130	295
W 150	140	100	180	590	250	245	130	295
W 250	170	140	190	650	290	280	130	340
W 350	260	195	255	700	305	295	181	385
W 400	240	195	-	700	180	440	-	-
W 600	500	195	-	750	180	460	-	-
P 1000	360	280	-	1300	210	560	-	-
P 1600	500	280	-	1500	210	600	-	-

This system is used for offshore diving applications. The maximum lowering capacity is 90 metres so it can be used for offshore platform diving operations as well. It consists of an A-frame with 2 approved manriding winches and a redundant electrically driven hydraulic power unit. All fit a 20" standard size container; even 2 of DLR-1250 will fit in one 20" container. One winch is used to lift and lower the dive bell, while the other for the clump weight; a third optional winch can be used as a utility/tool winch. The function of the clump weight is to keep the dive bell straight and steady under water. In case of an emergency or breakdown of the wet bell winch, the clump weight winch will be able to lift the dive bell and clump weight together.

Designed to fulfil the requirements of Lloyds and it also meets the UK HSE regulations for personnel lifting operations on offshore installations. The winches and A-frame are especially made for personnel lifting suitable for diving operations and offered with a Lloyds Register of Shipping (LRS) Design Appraisal Certificate and full material traceability. They have passed EC testing for these applications, i.e., both the winches and their technical files are in compliance with the requirements of the EC Machinery Directives. The DLR-1250 model also complies with IMCA regulations and comes with an ATEX certificate.

Standard features

- Compact units with minimal deck space usage
- Suitable for Sea state 2-3
- Easily rigged and set up
- Main diving bell winch OHR 1.5, WLL 1250 kg @ 40 m/min
- Clump weight winch OHR 1.5, WLL 1250 kg @ 40 m/min
- Limit switches for upper limit
- Double fail-safe braking on both winches
- Lifting height (lowering depth) 90 metres
- Utility winch 500 kg @ 25 m/min. (optional)
- Fleet angle compensators for winches
- Power supply: 380-460 V AC, 50/60 Hz
- Hydraulic cylinders for deploying the A-frame (optional)
- Forklift pockets for easy handling
- Container sockets for easy fastening
- Welding brackets for deck mounting
- Readout unit of paid-out wire rope
- HPU Eexd ATEX, 100 l/min. @ 180 bar, redundant pump system and cross-over manifold and quick release connections
- Hydraulic proportional valves for winches and A-frame operation
- Operating conditions -20°C to 50°C
- Full material traceability (3.1 - EN 10204) on load-bearing parts
- Easy transportation because it fits a standard 20" container size
- Fitted with twist-free wire ropes with high (10x) safety factors
- IMCA and Lloyds compliant
- Flood light, Eexd
- Standard open basket with bottle mounting bracket, fall-out prevention, pay load 650 kg
- Clump weight: 400 kg
- Dimensions; operational 2976 x 2502 x 4017 mm, collapsed 4558 x 2178 x 1111 mm
- Weight excl. HPU; 2750 kg.

For more specific details please send us or one of our authorised dealers your inquiry.



Hose reel, umbilical or transponder winches are mainly built for purpose. Winches are built to order and can be executed with a self-braking wormgear or planetary gear, depending on the load required. The drive can be either electric, hydraulic or pneumatic. The hose reels are mainly used to reel hoses for fresh water supply, MDO fuel supply and hydraulic oil or to reel electrical power supply cables.

The umbilical winches are, generally, used to reel a combination of hoses, signal cables, coax or even fibre optic cables. Most of them come with slip rings and/or rotating swivels. Transponder winches used for powered transponders are mainly used with electrical signal cables and have, in most cases, an electrical slip ring mounted. Winches can be supplied complete with an A-frame if required.

EMCÉ has supplied systems for all applications including reels with 6" stainless steel swivels or slip rings for high voltage. The versions we have supplied can be found on the following type of constructions: offshore heavy lift vessels, offshore semi-subs, diving support vessels, research vessels, cable and pipe laying vessels and offshore pile-driving barges.

Standard features:

- Self-braking wormgear, helical bevel, planetary or slew gear transmissions
- IP 56 TENV 400 V AC / 3 phases / 50 Hz braked motors (or 440/3/60)
- Radial piston air or hydraulic motors
- Heavy duty construction
- Double layer 2-component conservation according ISO 12944 category C2-Low, colour RAL 5010
- Stainless steel slip rings (fibre optic or elec.)
- Stainless steel swivels
- Spooling devices

Available options:

- Explosion-proof electric motors
- Protective steel motor covers
- Alternative speeds
- Protective guards
- Available control options:
 - Control box IP 55 with push-buttons and emergency stop built acc. to NEN 1010
 - Control box IP 66 with low-voltage IP 65 remote control built acc. to NEN 1010
 - Load limiters
 - Frequency inverters for variable speed control
 - Wireless radio remote control systems
 - Limit switches
 - Pneumatic and hydraulic control systems

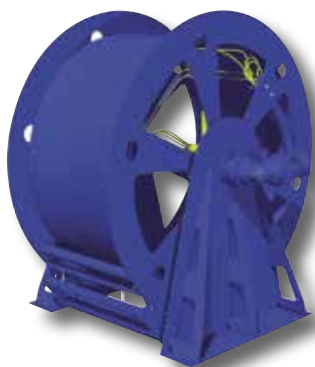

Umbilical winch



Hose reel

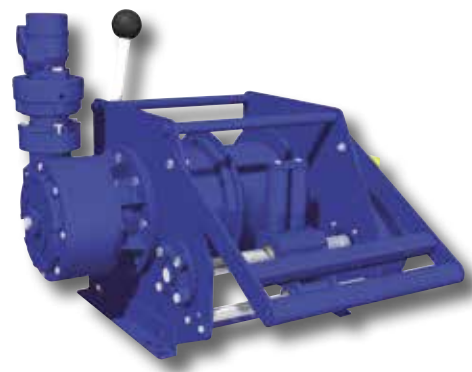

Transponder winch

Winch enquiry checklist

The first step in designing the right winch for a given application is to collect all relevant data. This can be done in a face to face or telephone conversation, but the most convenient and secure manner is by completing the below checklist and forward it by e-mail to the EMCÉ sales and engineering office. On the basis of the checklist further questions can be asked or a preliminary proposal formulated.

Company name : _____

Personal name : _____

Fax/tel./e-mail : _____

Latest bid date for offer : _____

Required delivery time : week _____ 200__

Short description of application : _____

Sketch of application available : no / yes, find enclosed

No. of winches : _____

Type (if known) : _____

Application : *lifting / pulling / traversing / traction /
pile-driving / anchoring / mooring*

Working Load Limit (WLL/SWL) : _____ kg or daN _____ in 1st layer,
_____ in top layer

Speed : _____ m/min in _____ layer, fixed /
variable / 2-speed; _____ / _____ m/min.

Rope diameter : _____ mm

Rope length : _____ m in max. _____ layers

Drum dimensions (if known) : core diameter _____ mm, length _____ mm,
flange diameter _____ mm

Drum finishing : smooth / helical grooved / grooved according to DIN /
Lebus

Special drum features : 1 or _____ cable anchors / drum divider flange /
cable kicker

Environmental conditions : Ambient temp. - _____ °C. / + _____ °C,
Hazardous zone, _____
Hostile, details; _____

Duty : continuous / intermittent; _____ times per day / week /
month

Supply : **electric** ; _____ V AC / _____ phase /
_____ Hz

electric ; _____ V DC

hydraulic ; _____ l/min @ _____ bar

pneumatic ; _____ l/sec. @ _____ bar

Brake motor required : yes / no

Required electric motor

IP classification : IP 54 / 55 / 56 TENV / IP 56 TEFC / 68 TENV

Special electric motor features : PTC / tropicalisation / brake lifter / hand crank / encoder /
heater

Winch options : clutch ; yes / no, remotely operated yes / no
band brake ; yes / no, automatic yes / no,
holding force _____ kg
pressure roller ; yes / no, steel / stainless steel / nylon
drum guard ; yes / no
spooling gear ; yes / no
emergency cranking ; yes / no

Controls electric : Local panel with push-buttons yes / no
Local panel with push-buttons and line pull limiter yes / no
Pendant remote control yes / no
Pendant remote control and line pull limiter yes / no
Foot pedal control for capstan (1 direction - 1 speed) yes / no
Foot pedal control (2 directions - 2 speed/variable) yes / no
Panel mounted on to winch frame yes / no
Protection class panel IP 55 / IP 65 / IP _____
Spindle limit switch 2 / 4 / more _____ contacts yes / no
Space heater (_____ VAC / _____ Hz) yes / no
Frequency inverter for variable speed control yes / no
Constant tensioning yes / no

Pneumatic controls : On winch (joystick type valve); fixed/proportionally yes / no
Pilot valve on winch only yes / no
Remote pendant with pilot emerg. stop,
length _____ m yes / no
Rem. pendant with main emergency. stop,
length _____ m yes / no
Remote panel mount joystick yes / no

Controls hydraulic : On winch; fixed speed / proportionally yes / no
Remote pilot / solenoid yes / no
Other _____

Finishing, system : Makers std. (2 comp.) / Marine paint syst. /
Special _____

Finishing, colour : Makers std. RAL 5010/ RAL
_____ / _____

Overall dimensions limited to : _____ x _____ x _____ mm. (L x W x H)

Classification : LRS / BV / GL / ABS / ABS + CDS / DNV / TUV / _____

Special document-
tation requirements : yes / no; _____

Other requirements : _____

Typical Approval drawing

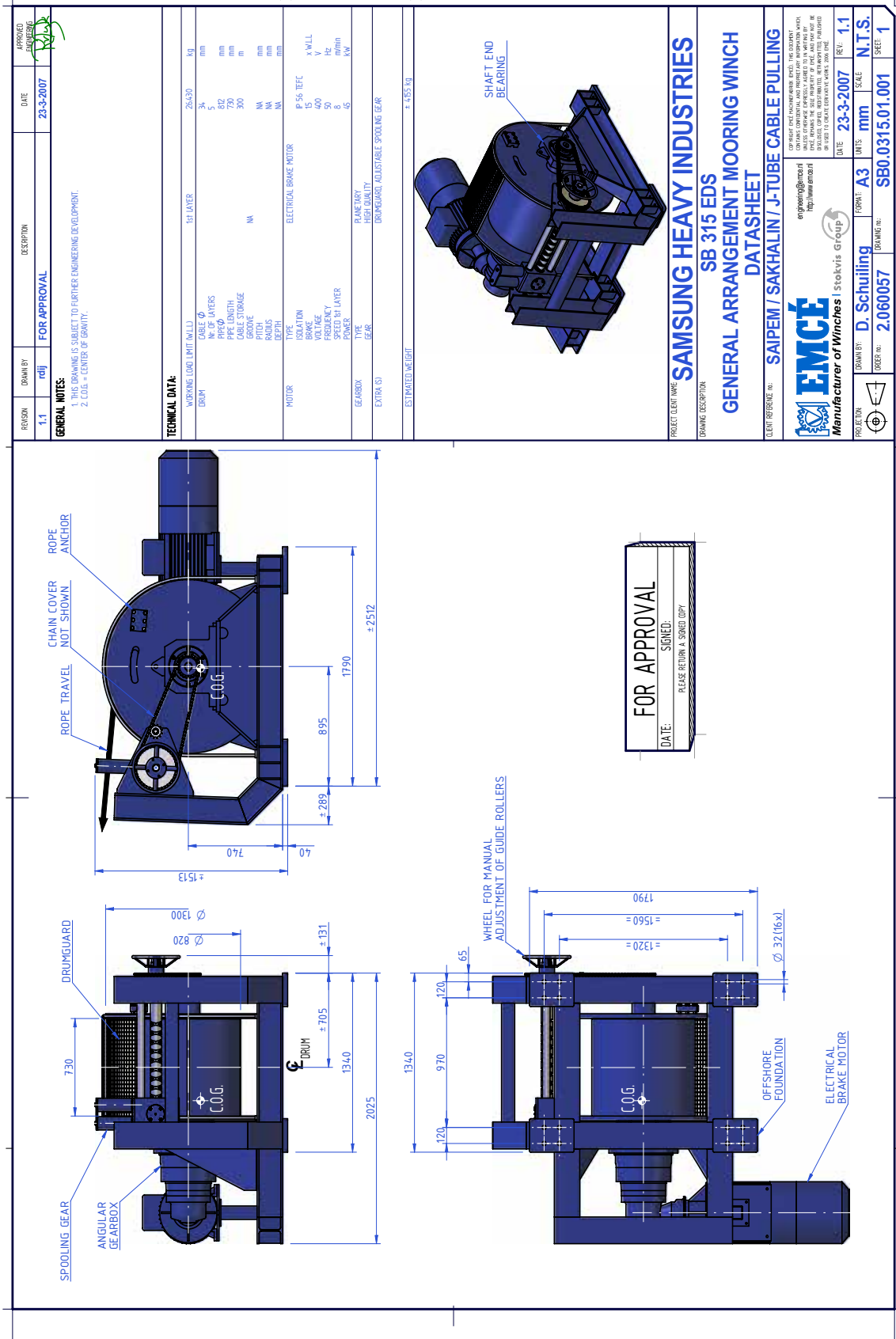

This is an example of a drawing for approval.

Typical EMCÉ winches as delivered to customers

EMCÉ winches have been supplied the world over, to a great variety of customers and for many different tasks and environments. Below a limited selection of winches that were delivered in the recent past.

A 41H ELPS

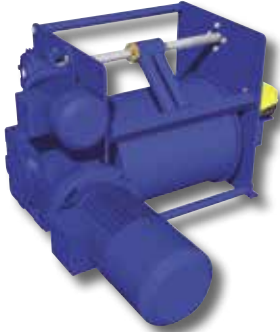

DP 3 TRANSPONDER WINCH
FOR SEATRUCKS JASCON 5

WRS 2.3 EBC

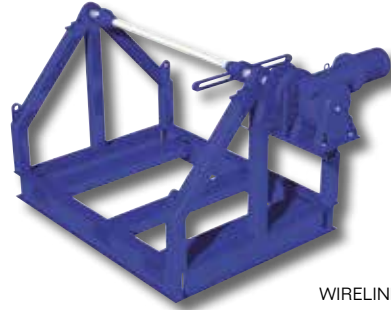

WIRELINE ROPE SPOOLER
FOR ONGC INDIA

SR 30 H2

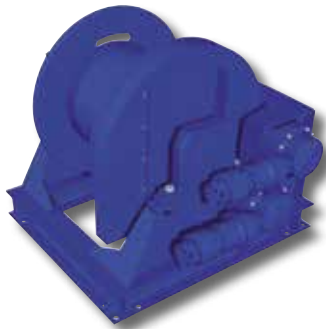

30 TON HYDRAULIC
WINCH FOR UNOCAL
THAILAND

SB 306 H

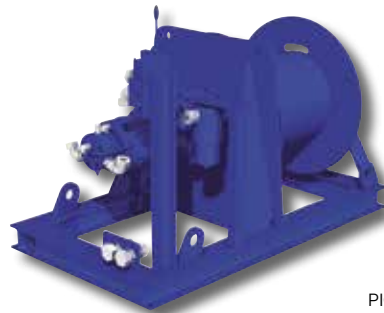

5 TON HYDRAULIC
PICK-UP WINCH FOR
APL BUOY

OAW 7.5 GP16

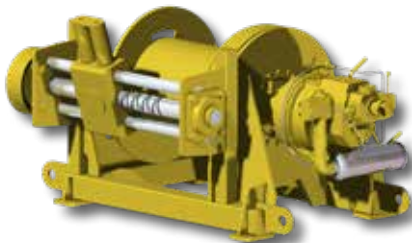

10 TON PNEUMATIC
WINCH FOR JURONG
SHIPYARD PTE LTD

SR 315R EDS



30 TON J-TUBE CABLE
PULLING ELECTRIC
WINCH FOR SAMSUNG
(SAKHALIN PROJECT)

OAW 5.0 GP10

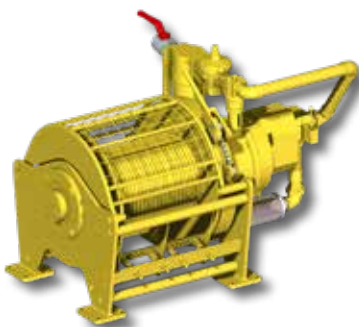

5 TON PNEUMATIC
WINCH FOR M.I.S. U.A.E.

SB 316R HS



40 TON DAVIT WINCH
FOR SAS GOUDA

Typical EMCÉ winches as delivered to customers

SB 319R H

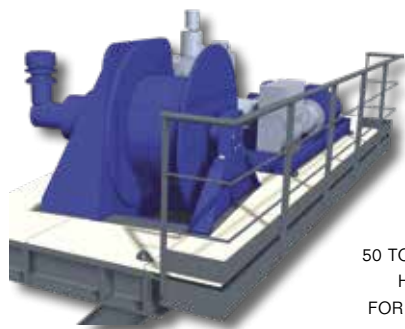

50 TON JUMPER HOSE
HANDLING WINCH
FOR BLUEWATER ABU
CLUSTER FSO

SR 20 E2



30 TON ELECTRIC JACK
-UP MOORING WINCH FOR
THULE DRILLING (THULE
POWER

SR 40 E3



40 TON ELECTRIC
WINCH FOR LUDAN
FOR METHANE
BARGE PROJECT

SC 50 E

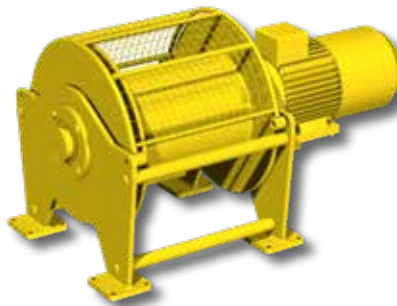

5 TON ELECTRIC
TUGGER WINCH
FOR FLEXI FRANCE

SB 310R GP16

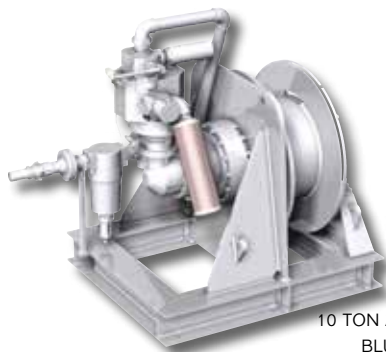

10 TON AIR WINCH FOR
BLUEWATER BUOY

SC 10 HBCS



900 KG HYDRAILIC
DYNAMIC ANCHOR
WINCH FOR THE
DUTCH NAVY

SB 307 RLV



PNEUMATIC UMBILICAL
WINCH FOR PARKER
HANNIFIN

SB 311R EDGP



10 TON ELECTRIC
WINCH FOR DUBAI
MARITIME CITY SHIFLIFT
MOORING SYSTEM

Note: This is only a small selection from the more than 30,000 winches EMCÉ has supplied over the past 35 years. EMCÉ produces approximately 1300 custom winches and 400 standard winches each year. A more specific overview of our products can be obtained from the EMCÉ sales office.

Sales and service network

EMCÉ winches has a strong worldwide presence and takes great pride in her worldwide dealer network. In addition to our Voorhout Holland based factory team, the dealer network provides close commercial and technical support for our customers and their end-users with local knowledge. In addition, EMCÉ sales and support staff travel the world on a regular basis to meet and support customers and keep our dealer network up to speed regarding new technological developments.

Please check our EMCÉ website to find an EMCÉ dealer close to you, or simply contact the EMCÉ Voorhout office for contact details or direct advice.

EMCÉ winches historically has a strong presence in the petroleum industry. Even while other regions and other ways of producing oil are developing, the Middle East remains the heartland of oil production. To cater for the specific demand of the Middle Eastern region EMCÉ has a Kingdom of Bahrein based sales and support office to offer her commercial and technical services from inside the region to her customers and dealers in the region.

General terms and conditions

All tenders and contracts for deliveries by us inside and outside the Netherlands are governed by the sales and Delivery FME General Terms and Conditions for the mechanical and electrical industries of October 1998 filed under reference no. 119/1998 at the district court in The Hague.

Guarantee

EMCÉ guarantees that its winches are free of defects in material and workmanship for a period of one year from the date of purchase to the original user. EMCÉ will repair, without costs, any product found to be defective, including parts and labour charges, or, at its discretion, it will replace such products or refund the purchase price after deducting a reasonable allowance for depreciation, in exchange for the faulty product.

If any product proves defective within its original one year guarantee period, it should be returned to any authorised EMCÉ dealer: shipment should be prepaid and include proof of purchase and/or winch data sheet/test certificate.

This guarantee does not apply to products which EMCÉ has determined to have been misused or abused, improperly maintained by the purchaser, or where the malfunction or defect can be attributed to the use of non-genuine EMCÉ parts.

EMCÉ makes no other guarantee, and all implied guarantees including any guarantee of merchantability or fitness for a particular purpose are limited to the duration of the expressed guarantee period as set forth above. EMCÉ's maximum liability is limited to the purchase price of the product and in no event shall EMCÉ be liable for any consequential, indirect, incidental, or special damages of any nature arising from the sale or use of the product, whether based on contract, tort, or otherwise.

Stokvis Group

The Stokvis Group is a trading and manufacturing organisation with its headquarters in Voorhout, a rural town 25 minutes away from Schiphol Amsterdam Airport.

The company's presence does not limit itself to her branches in the Netherlands, Germany, Belgium and Bahrein, but through her products is present all over the world.

The group started now over 50 years ago trading in electric motors, but through autonomous growth and careful acquisitions the group now covers a wide field of competence in several disciplines, operating on both the Dutch and international markets.

Currently employing over 350 staff, the Stokvis Group is active in the following fields:

- Drive and control technology
- Design and construction of winches
- Horizontal and vertical transport solutions
- Automotive and Truck equipment
- MRO services for equipment and installations
- Advanced water treatment equipment
- Products and services for the international yachting market
- Recruitment and Staffing services.

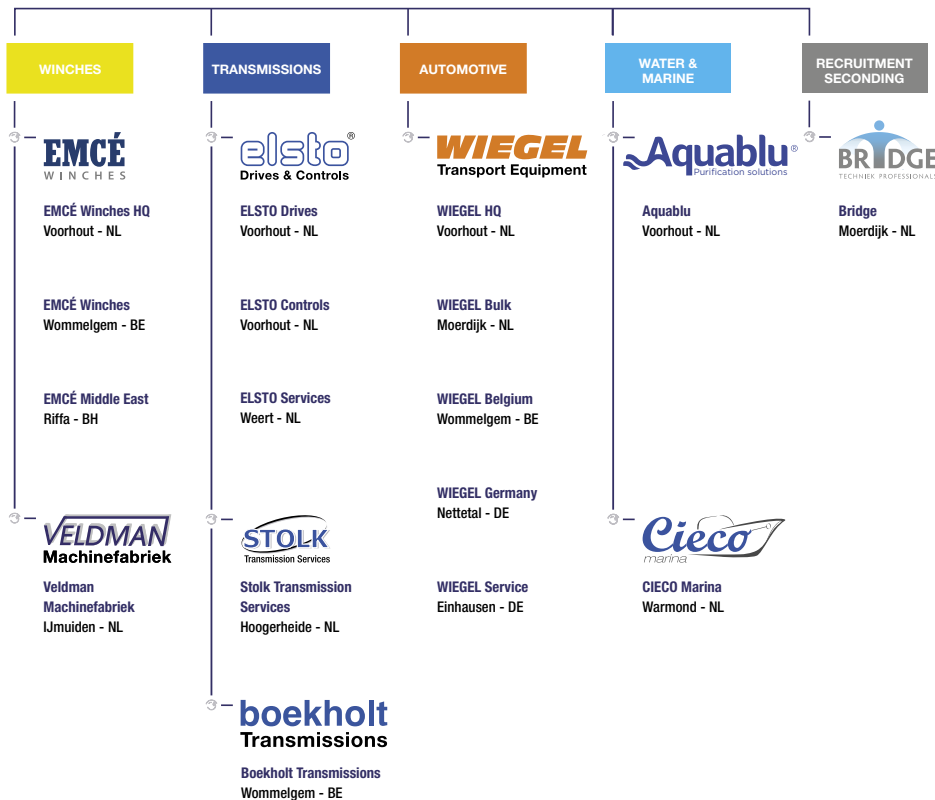



EMCÉ
WINCHES

EMCÉ Winches
's Gravendamseweg 53
2215 TC Voorhout - The Netherlands
+31 (0)252 21 40 80
sales@emce.com
www.emce.com

EMCE Middle East
P.O. Box 20705
Manama - Kingdom of Bahrain
+973 33 99 22 42
mesales@emce.com
www.emce.com

Superior service in every part of the world

Our winches can only be superior if our services are too. EMCÉ winches are built to last and perform across the globe, under most severe conditions. Clients can rely on the outstanding quality of our products. If a winch needs to be commissioned, modified or examined, our worldwide network of dealers assures you of excellent support and maintenance. EMCÉ's stock and spare parts are globally available at short notice. Continuity of your business is therefore guaranteed. Anytime, anyplace. EMCÉ, every winch a winner.