

G E B U W I N
quality winches

Catalogue 2024

G E B U W I N
quality winches

The strength of 77 years experience

Preface

Gebuwin was founded in 1947 by the brothers Buunk in Winterswijk, The Netherlands. Since 1965, the company is still owned by the Siertsema family. We, Robert and Alan Siertsema, belong to the fourth generation of Gebuwin owners and with that, we feel the responsibility to continue Gebuwin in the best way possible. After all, Gebuwin has a valuable history when it comes to products and customers. We want to honour Gebuwin's historical values and as well as this, continue to innovate without losing these values. Growing up, we have heard a lot from what was going on at Gebuwin through family, customers and colleagues. There are three core values that have proven to be important to Gebuwin, namely: quality, flexibility and drive. These core values form an important vision that we want to continue at Gebuwin.

Quality

Gebuwin manufactures products designed to move heavy loads. Moving these loads always entails safety risks. For this reason, it is essential that our products can cover this risk, which calls for high quality products. Your trust in our product is very important to Gebuwin.

The entire production process is in our own hands, which ensures a high quality assurance. All raw materials originate from Europe and everyone at Gebuwin is fully qualified and has all the necessary certificates. This dedication to excellence is reflected in our ISO 9001 certification, a testament to our unwavering commitment to quality.

Flexibility

In a world where market needs are constantly changing, Gebuwin is known for responding quickly and effectively. Whether answering customer requests, responding to unique requirements, or meeting the extensive documentation requirements of large international customers, Gebuwin's agility makes all of this possible. This flexibility is due to our young, dynamic team and our

streamlined organisational structure. It enables us both to deliver tailor-made solutions for specific customer needs and to react quickly to market changes. At Gebuwin, we believe that our flexibility not only distinguishes us on the market, but is also essential to our continued success in meeting our customers' expectations.

Drive

At Gebuwin, our drive is one of our specific characteristics. With a spirited team keen on growth, we thrive on tackling new challenges that propel us ahead. We are dedicated to enhancing our existing products and creating innovative ones that meet our customers' needs. Our commitment to innovation is about constantly improving and seizing new opportunities in the market. It's this drive to learn, improve, and excel that ensures that we continue to provide our customers with the very best products.

We hope that we were able to introduce you to the world of Gebuwin; a beautiful company that continues to manufacture beautiful lifting products for more than 75 years.

Kind regards,
Robert & Alan Siertsema



Alan Siertsema
Commercial director



Robert Siertsema
Operational director



The team

At Gebuwin, we're a small but dedicated team, all focused on giving our customers the best each day. Our engineers, sales, and production teams bring years of experience to the table, working together to make sure we deliver top-quality products. In our two workshops that add up to more than 2000 square meters, we stick to what we believe in: quality, flexibility and drive.

We aim for top quality, on-time delivery, and great service. Our goal is to be there for you, adapting to meet your needs, whether it's with our regular products or the special ones we make just for you.

Welcome at Gebuwin.

Visit our website for more information:

www.gebuwin.com



77 years

leading in lifting products



37 countries

international based



12 industries

active in a wide range



Index

1

Preface

2

About Gebuwin

4

Industries

8

Custom engineering

10

Hand winches

30

Electric winches

38

Battery drill winches

46

Swivel davit cranes

56

Accessories

65

Terms and conditions

Industries

There are many industries in which loads need to be moved. This is done by means of; hand winches, electric winches and davit cranes and these are therefore used frequently. A number of these industries are the maritime industry with elements such as shipbuilding and offshore. The water sector, mechanical engineering, mineral extraction but also defence and theatre & entertainment, sports & wellness, medical and petrochemical industries are not lacking in Gebuwin's list. In the following pages, our three biggest industries are explained in more detail, namely: maritime, water sector and theatre.



Index

- Maritime p. 5
- Water sector p. 6
- Theatre and entertainment p. 7

Maritime industry

The maritime industry is very important to Gebuwin. It is our largest market. We therefore divide this industry into a number of sub-industries, namely: shipbuilding, dredging, maritime suppliers, marine, fishing, inland navigation and offshore.

Strict safety requirements

Due to the usually challenging weather conditions, combined with strict safety requirements in this sector, our hand winches must be of the highest quality. Gebuwin has therefore developed a hand winch especially for this industry; the marine winch. All parts of the winch that are exposed to the weather are made of stainless steel 316 (highest corrosion resistance). The marine winch has a worm gear transmission to increase safety when hoisting, pulling or tensioning heavy loads. The transmission is enclosed with an IP54 rating (International Protection Rating). It is also possible to apply a marine coating to the winches. We use a very durable coating system for environmental conditions classified as CX (very high corrosivity, marine formerly known as C5M). visit [our website](#) for more information.

Unique features

- ◊ Three coats of paint in accordance with the CX (C5M) offshore coating
- ◊ Available in a stainless steel 316 version
- ◊ High quality and high corrosivity
- ◊ Resistant to splash water IP54
- ◊ Available with an ATEX certification
- ◊ Possible to operate with air or electric motor

Related products



Worm gear marine winch

Page 15



Worm gear SST316 winches

Page 17



Pneumatic motor

Page 63



[Completed project \(discover more completed projects\)](#)

Offshore windmill park

As an example, Gebuwin's hand winches are used in wind energy to keep the blades of wind turbines, which are placed on the North Sea by ships, in position on the ships. Due to possible severe weather conditions, it is important that the blades do not shift. Slings are stretched over the blades to keep them in place. A tensioning capacity of 5 tonnes is required for this application.

Water sector industry

Gebuwin has a modern designed foldable lifting davit crane. It has been developed for water purification plants and water production companies. This swivel davit helps you to carry out your work efficiently without the risk of physical strain.

Hoisting pumps

At sewage treatment plants and production sites, there are many places where loads such as pumps have to be lowered and lifted. For this reason there are a lot of hand winches and hoisting davits required. Gebuwin has developed a number of lifting davits especially for this application. The goal was to develop a davit crane in such a way that it is easy to move, given the many positions where a load has to be lifted.

Gebuwin offers three types of lifting davits, which vary in lifting capacity and reach length. Because of the integrated winch and cable, the davit is not only compact but also low in maintenance. The crank is also adjustable in length so that the hoisting speed can be adjusted. visit [our website](#) for more information.

Unique features

- ◊ Light weight and ready to use in seconds
- ◊ Ball bearing for smooth operation
- ◊ 360° rotatable
- ◊ Integrated winch and cable
- ◊ 3 arm lengths available of 60, 80 and 100 cm
- ◊ Available in painted, galvanised and stainless steel 316 finish
- ◊ Various floor sockets available

Related products



Swivel davit painted

Pagina 47



Swivel davit zinc plated

Pagina 47



Swivel davit Stainless steel

Pagina 49

[Completed project](#) ([discover more completed projects](#))

Customized Swivel Davit crane

Many regional water authorities or water companies use pumps in wells that already have a cable attached to the pump. It is therefore important that the pump can be lifted out of the well with the current cable. For this purpose we have developed a special davit crane. This lifting davit does not have an integrated winch, but the winch is on top of the davit, which makes it possible to first wind the existing cable onto the winch drum before lifting the pump out of the well.



Theatre & Entertainment industry

The loads that need to be lifted in this industry are diverse due to the different locations such as: theatres, multi-purpose halls, exhibition halls, film, television and radio studios, concert halls, schools, bars, clubs, open-air stages and other spaces for shows and events.

Strict safety requirements

In the stage- and entertainment industry, there is a need for reliable winches with the highest safety requirements. These winches must ensure the safety and health of people working or staying under suspended loads. Given the diversity of applications and locations, since May 2020 a new European standard has been introduced for winches in this industry. Prior to this, there was no central European standard. However, there are commercial, non-European, standards such as DGUV 17 and BGV C1.

Gebuwin's theatre winch complies with the new European standard. The theatre winch is a safe and high-quality winch that has been developed, especially for the entertainment world and is therefore new in our range. In short, it's a great acquisition for Gebuwin, which literally and figuratively has the right to be "in the picture". visit [our website](#) for more information.

Related products



Theatre winch TW300

Page 19



Theatre winch TW300 L

Page 19

Unique features

- ◊ The worm gear transmission has a natural braking effect
- ◊ The winch meets safety factor 8
- ◊ Grooved drum for single layer cable storage of 10 or 20 metres
- ◊ Pressure roller for neat cable reeving
- ◊ 2 load pressure brakes with double ratchet system to hold the load safely and stable in any position
- ◊ Double cable attachment for extra safety
- ◊ Suitable for wall mounting
- ◊ The crank can be secured and adjusted in length
- ◊ Closed gearbox to prevent accidents



[Customized project \(discover more completed projects\)](#)

Hanging art in shops

In a large department store, works of art are hung above an escalator. People are standing on the escalator under this presentation, so safety is very important. The new theatre winch is ideally suited for this, given the strict and additional safety requirements of the winch.

To reduce the risk even further, the cables are attached to the wall when the artworks are lifted into position.

Custom engineering

In this catalogue, you will find a wide range of standard winches. These standard products have proven themselves over the past 75 years, thanks to continuous product optimisation and technical development.



Custom engineering

Besides optimising our standard products, Gebuwin invests a lot in developing new products that are specifically designed for certain industries.

Development of new products

Gebuwin has developed the 'marine' winch with features seawater resistance, offshore coating and stainless steel parts that ensure a high corrosion resistance.

The latest product that Gebuwin has developed is the theatre winch that complies with the new European theatre and entertainment standard: EN17506.



completed project ([discover more completed projects](#))

Non-magnetic winch

The developed winch hoists a magnet from an MRI scanning machine and must therefore be able to brake at any moment during the lifting movement. By using high-quality stainless metals such as aluminium and a brass alloy for the worm gear, together with special grease lubrication, the worm gear can reach the desired speed and stop immediately. A wide grooved drum ensures that two stainless steel wires run up and down the worm gear carefully.

Complex modifications

Besides the development of these new industry-oriented winches, Gebuwin is strong in 'custom engineering'; tailoring hand and/or electric winches to customer's needs. Gebuwin is not afraid of both simple and very complex adjustments to our range of winches.

If you would like to know more about the possibilities, please contact us via e-mail info@gebuwin.com, telephone +31 54 353 2600 or visit our [website](#) for more information.



completed project ([discover more completed projects](#))

Military winch

For a military application we designed a special winch with a pull load of 2500 kg that can be set into free spool with the aid of a quick release attachment. The drum of the winch is suited for a 50 mm wide webbing to pull the load with a hand crank or an air driven motor. An adjustable slipping drum brake prevents the coming loose of the webbing at the end of the free spool track. A build in overload protection prevents damage of the installation by the operator. Cams and handle bars on the winch make a quick mounting possible.

Hand winches

There are generally three reasons for using hand winches. They are used as back-up systems or when the frequency of use is low. Finally, a load can be moved in a remote location where there is no electricity.

Our hand winches can be divided into two types of transmission, namely; a worm gear and a spur gear. Within the worm gear hand winches, we also have two industry specific winches, the stainless steel winches and the theatre winch.

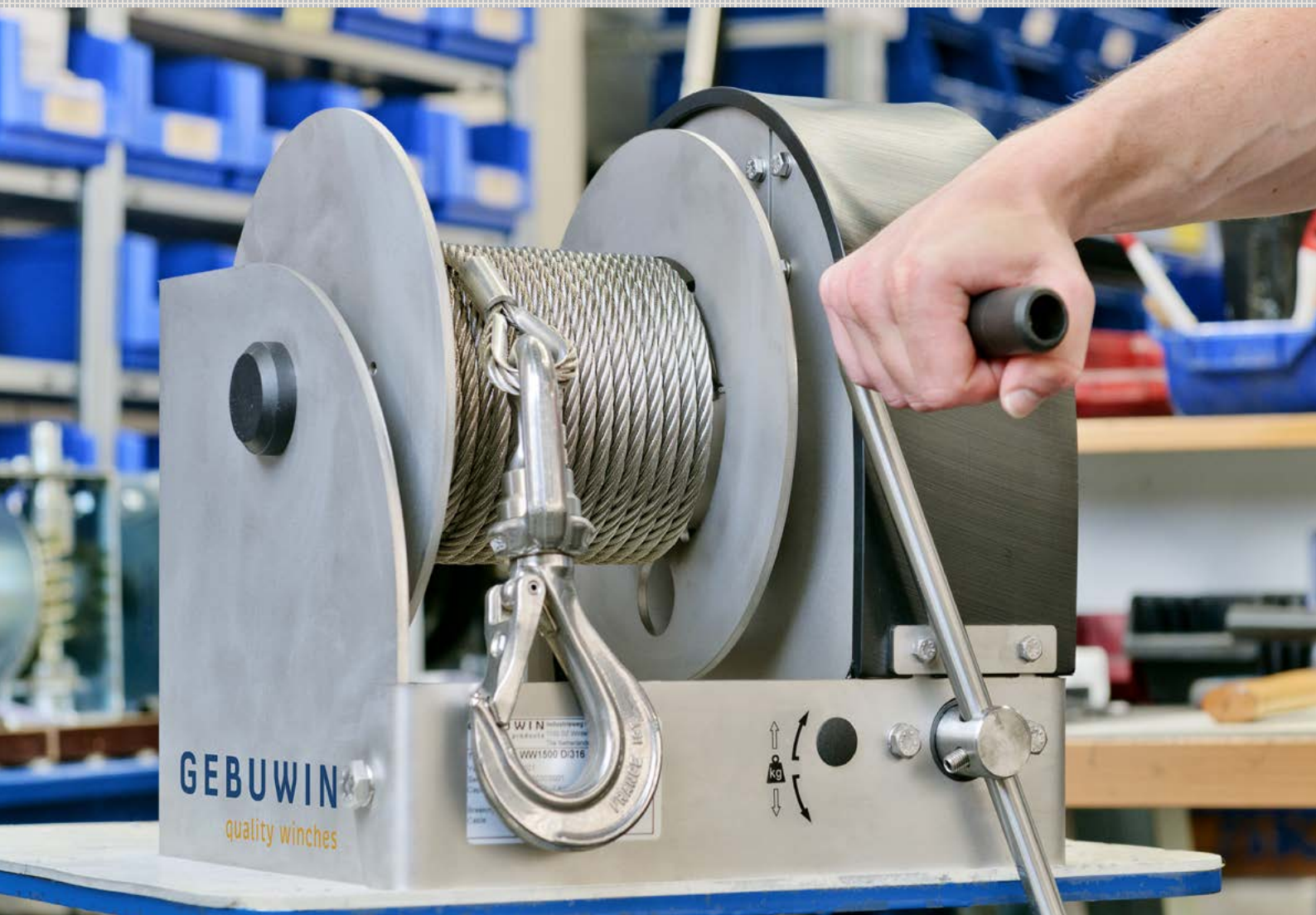

Index

- | | | | |
|---|-------|------------------------------------|-------|
| • Worm gear hand winches 250 - 1500 kg | p. 11 | • Spur gear winch 150 kg | p. 21 |
| • Worm gear hand winches 2000 - 7500 kg | p. 13 | • Spur gear winches 300 - 750 kg | p. 23 |
| • Worm gear marine winches 3000 - 5000 kg | p. 15 | • Spur gear winches 1000 - 1500 kg | p. 25 |
| • Worm gear SST316 winches 500 - 5000 kg | p. 17 | • Spur gear console winch 600 kg | p. 27 |
| • Theatre winch 300 kg | p. 19 | | |

Worm gear hand winches

250 – 1500 kg

Description of the winch

This hand winch is very safe due to the natural braking effect of the worm gear transmission in combination with the load pressure brake. In addition, the winch is easy to use, can be mounted in various ways and has a cable storage up to 120 meters.

Product specificaties

- winch suitable for lifting and pulling in compliance with EN13157
- static safety factor 4
- load pressure brake with double ratchet system for safe stable hold of the load in any position
- cable outlet upwards, downwards or at rear
- adjustable crank
- suitable for wall and (optional) floor mounting
- 1 layer of paint

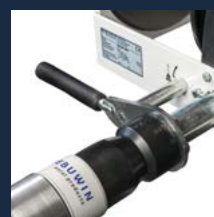
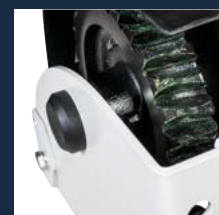
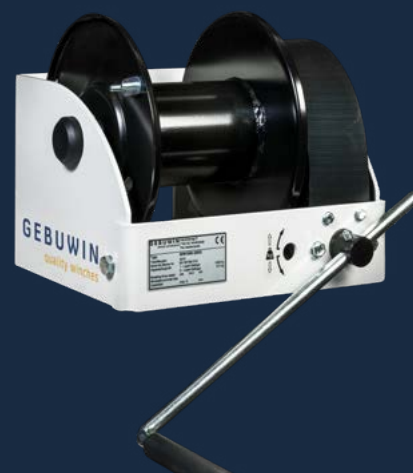

Options (code)

- zinc-plated finish 6 - 8 micron (EV)
- 2 layers of paint (2L)
- grooved drum (GD)
- 2 drum compartment (2D) or multiple up to 8 (XD)
- suitable for Dyneema rope (DY)
- pressure roller (PR)
- suitable to use with webbing belt W:50 mm D:2 mm (WB)
 - belt storage WW250: 10 m
 - belt storage WW500 - WW1000: 14 m
- suitable for floor mounting (FM)
- ATEX certified zone 2 and 22 (EX)
 - CE II 3G Ex IIC T4 Gc, -20°C<T amb <+70°C
 - CE II 3D Ex IIIC T135°C Dc, -20°C<T amb <+70°C
- custom options possible - [on request](#)

Accessories

- steel, stainless steel or fiber rope ([p. 57](#))
- pulley block ([p. 59](#))
- electric or airmotor as from WW1000 ([p. 63](#))



[Product & instruction video on YouTube](#)

Technical specifications WW250-1500

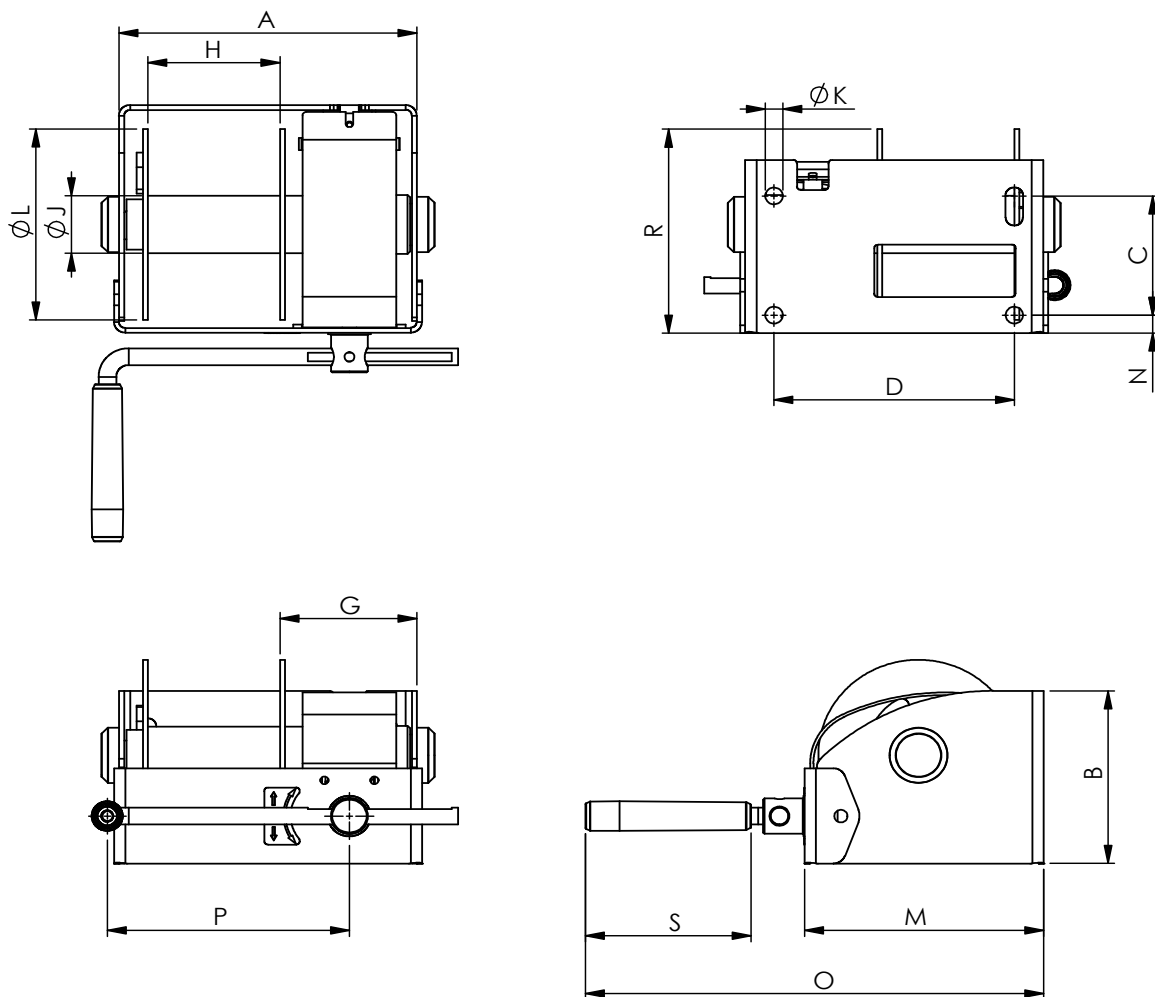

Dimensions (mm)	A	B	C	D	G	H	J	K	L	M	N	O	P	R	S
<u>WW250</u>	238	145	100	192	107	105	48	14	160	191	15	365	325	171	132
<u>WW500</u>	269	160	115	223	108	135	70	14	190	221	15	393	325	193	132
<u>WW1000</u>	302	195	141	254	109	162	102	17	240	266	15	440	350	263	132
<u>WW1500</u>	302	250	178	254	109	162	102	17	240	278	15	451	350	306	132

Technical specifications	Unit	<u>WW250</u>	<u>WW500</u>	<u>WW1000</u>	<u>WW1500</u>
Capacity 1st layer	kg	250	500	1000	1500
Capacity 4th layer	kg	179	355	722	1025
Capacity top layer	kg	92	224	527	846
Rope diameter-Ø	mm	4	6	8	10
MBL of cable	kN	9	17	34	51
Rope storage 1st layer	m	3,6	4,3	5,5	4,2
Rope storage 4th layer	m	18,7	22,8	29,3	24
Rope storage top layer	m	104	78,2	72,5	41
Lifting speed	m/min	1	1,2	0,8	0,5
Crank effort at full load	kg	5	10	13	14
Weight (without rope)	kg	10	13	22	24
Article number	no.	77281100	77281350	77281600	77281850

Worm gear hand winch

2000 – 7500 kg

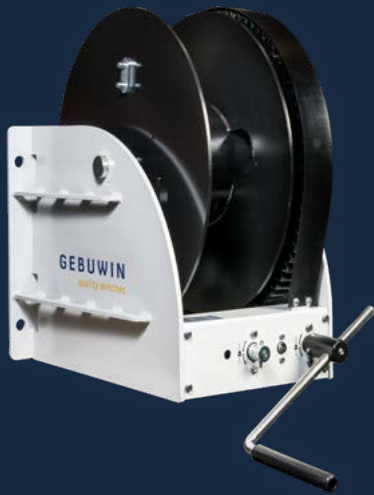

Description of the winch

This hand winch is very safe due to the natural braking effect of the worm gear transmission in combination with the load pressure brake. In addition, the winch is easy to use, can be mounted in various ways and has a cable storage up to 120 meters.

Product specifications

- winch suitable for lifting and pulling in compliance with EN13157
- static safety factor 4
- load pressure brake with double ratchet system for safe stable hold of the load in any position
- cable outlet upwards or at rear
- adjustable crank
- suitable for wall and (optional) floor mounting
- 1 layer of paint



Options (code)

- zinc-plated finish 6 - 8 micron (EV)
- 2 layers of paint (2L)
- grooved drum (GD)
- 2 drum compartment (2D) or multiple up to 8 (XD)
- suitable for floor mounting (FM)
- suitable for Dyneema rope (DY)
- pressure roller (PR)
- free-spooling device for pulling applications. To disengage the drum (FS)
- free-spooling device with additional friction brake for controlled cable unwinding (FSB)
- ATEX certified zone 2 and 22 (EX)
 - CE II 3G Ex IIC T4 Gc, -20°C<T amb <+70°C
 - CE II 3D Ex IIIC T135°C Dc, -20°C<T amb <+70°C
- custom options possible - [on request](#)

Accessories

- steel, stainless steel or fiber rope ([p. 57](#))
- pulley block ([p. 59](#))
- electric or airmotor as from WW1000 ([p. 63](#))

CE   [Product & instruction video on YouTube](#)

Technical specifications WW2000-7500

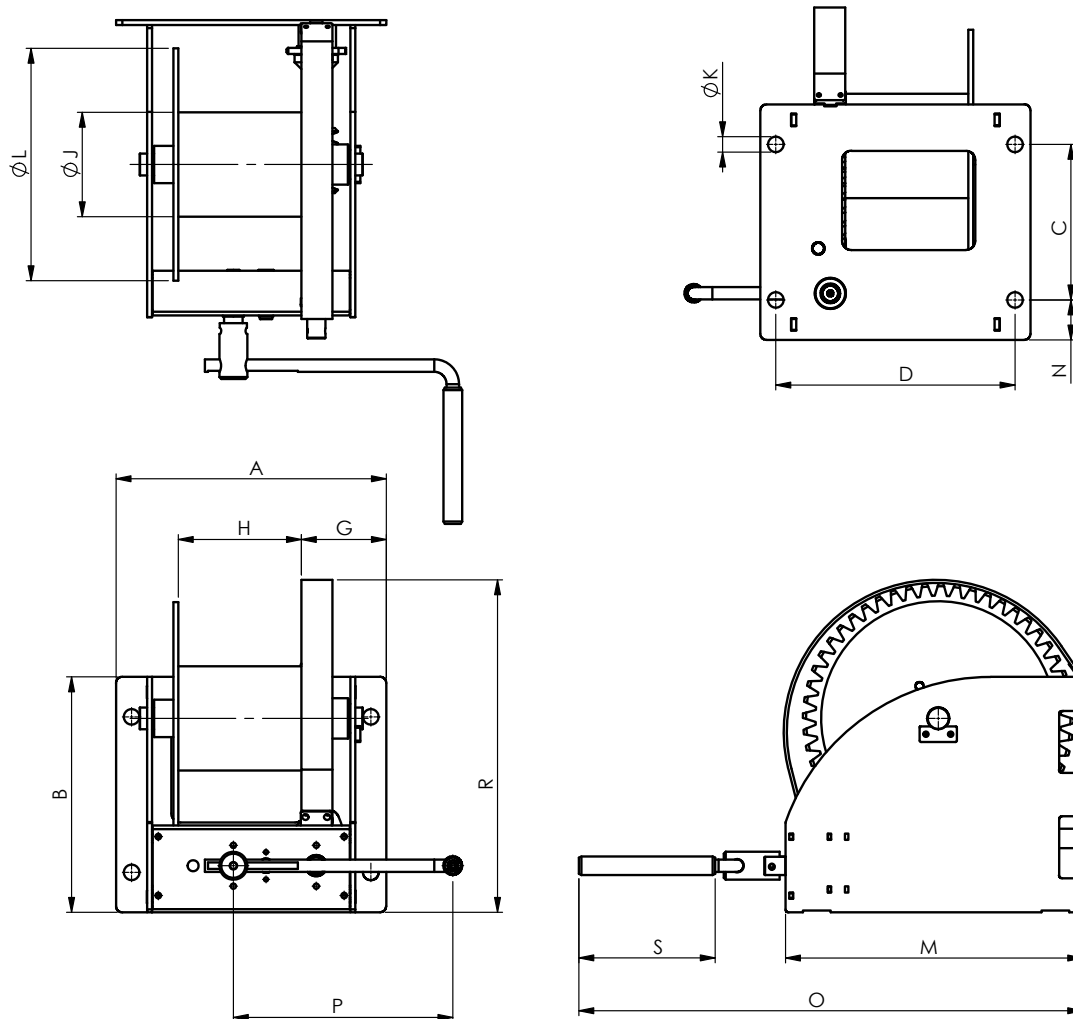

Dimensions (mm)	A	B	C	D	G	H	J	K	L	M	N	O	P	R	S
<u>WW2000</u>	410	310	196	360	137	177	133	25	312	372	57	705	380	434	220
<u>WW2500</u>	410	310	196	360	137	177	133	25	312	372	57	705	380	434	220
<u>WW3000</u>	436	380	251	386	137	203	168	25	375	480	65	813	380	536	220
<u>WW4000</u>	436	380	251	386	137	203	168	25	375	480	65	813	380	536	220
<u>WW5000</u>	436	467	316	386	137	200	219	25	437	515	75	847	380	618	220
<u>WW7500</u>	510	500	350	455	189	202	245	25	630	635	75	968	380	748	220

Technical specifications	Unit	<u>WW2000</u>	<u>WW2500</u>	<u>WW3000</u>	<u>WW4000</u>	<u>WW5000</u>	<u>WW7500</u>
Capacity 1st layer	kg	2000	2500	3000	4000	5000	7500
Capacity 4th layer	kg	1399	1748	2143	2858	3585	5252
Capacity top layer	kg	1075	1344	1667	2223	3276	3752
Rope diameter-Ø	mm	12	12	14	14	16	22
MBL of cable	kN	60	75	102	133	168	251
Rope storage 1st layer	m	5	5,4	5,7	5,2	5,9	4,2
Rope storage 4th layer	m	28,4	30	32,5	30,8	34,2	27,9
Rope storage top layer	m	60,5	63,1	68,7	53	57,8	72,7
Lifting speed (2nd shaft)	m/min	0,7 (0,3)	0,7 (0,3)	0,7 (0,3)	0,7 (0,1)	0,8 (0,2)	0,7 (0,1)
Crank effort at full load	kg	27 (15)	28 (15)	31 (14)	30 (13)	73 (15)	78 (15)
Weight (without rope)	kg	60	60	78	80	117	190
Article number	no.	77276000	77276200	77277000	77278000	77279000	77279500

Marine worm gear hand winch

3000 – 5000 kg

Description of the winch

This marine winch has a high corrosion resistance due to its many 316 stainless steel parts and 3 layers of C5M offshore coating. The hand winch is IP54 standardised which means that it is resistant to splash water and dust on the inside. In short: Robust!

Product specifications

- winch suitable for lifting and pulling in compliance with EN13157
- static safety factor 4
- load pressure brake with double ratchet system for safe stable hold of the load in any position
- closed gearbox to protect against environmental influence - protection classification IP54
- cable outlet upwards, downwards or at rear
- adjustable crank
- suitable for wall and (optional) floor mounting
- brushed steel frame with marine coating DIN/ISO 12944 C5M - RAL9005 (black)
- paint thickness is 240 micron in 3 layers
- stainless steel 316 parts: drum, crank and all outgoing shafts, bolts and nuts
- corrosion resistant

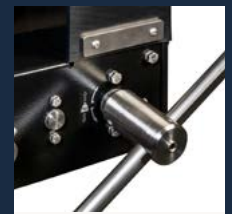
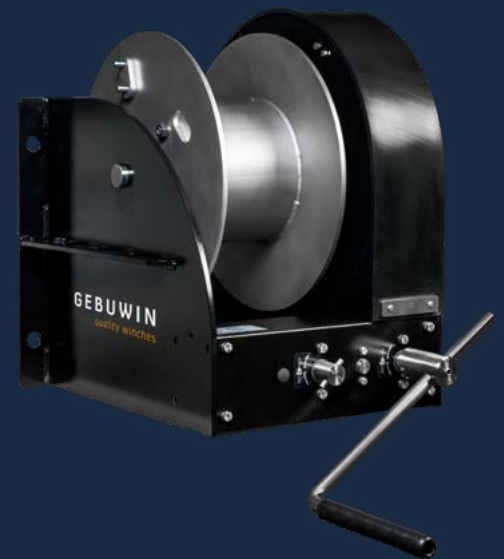

Options (code)

- complete stainless steel 316 frame ([p. 17](#))
- grooved drum (GD)
- 2 drum compartment (2D) or multiple up to 8 (XD)
- suitable for floor mounting (FM)
- suitable for Dyneema rope (DY)
- pressure roller (PR)
- ATEX certified zone 2 and 22 (EX)
 - CE II 3G Ex IIC T4 Gc, -20°C<T amb <+70°C

Accessories

- steel, stainless steel or fiber rope ([p. 57](#))
- pulley block ([p. 59](#))
- electric or airmotor as from WW1000 ([p. 63](#))



[Product & instruction video on YouTube](#)

GEBUWIN
quality winches

Industrieweg 6, 7102 DZ Winterswijk, The Netherlands
Telephone: +31(0)543 532600 Email: info@gebuwin.com

For more information, visit: www.gebuwin.com

Technical specifications MR3000-5000 C5M

*MR5000

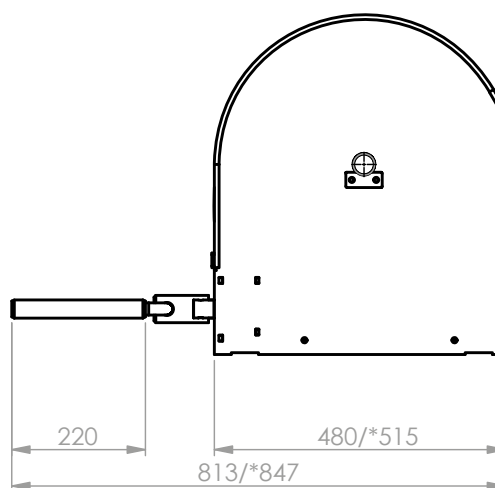
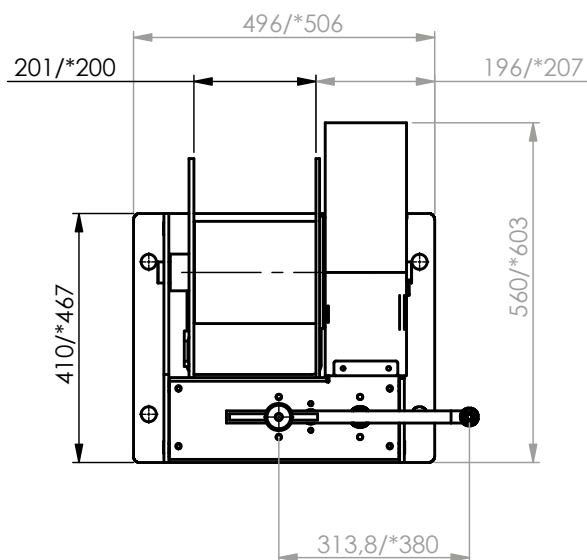
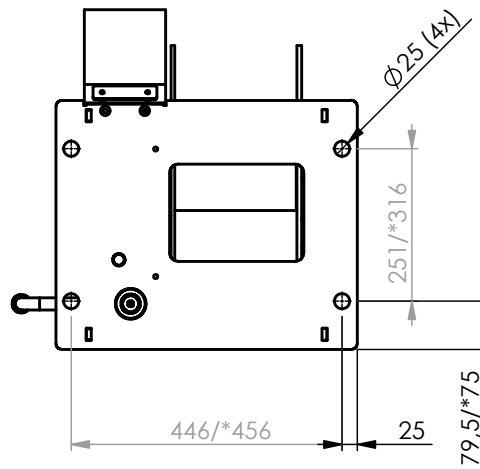
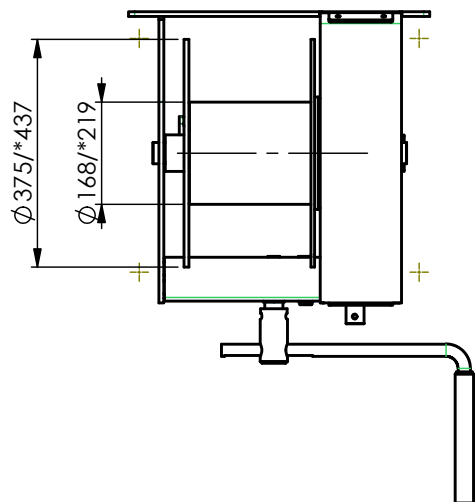

Technical specifications	Unit	MR3000 C5M	MR5000 C5M
Capacity 1st layer	kg	3000	5000
Capacity 4th layer	kg	2143	3585
Capacity top layer	kg	1667	3276
Rope diameter-Ø	mm	14	18
MBL of cable	kN	90	160
Rope storage 1st layer	m	5,7	5,2
Rope storage 4th layer	m	32,5	31,5
Rope storage top layer	m	68,7	42,9
Lifting speed (2nd shaft)	m/min	0,7 (0,3)	0,8 (0,2)
Crank effort at full load (2nd shaft)	kg	31 (14)	73 (15)
Weight (without rope)	kg	104	135
Article number	no.	77277080	77279080

SST316 worm gear hand winch

500 – 5000 kg



Description of the hand winch

This stainless steel winch is corrosion resistant and is made of stainless steel 316. The hand winch is IP54 classified which means that it is resistant to splashing water and dust on the inside. In short: a winch for the toughest conditions.

Product specifications

- winch suitable for lifting and pulling in compliance with EN13157
- static safety factor 4
- load pressure brake with double ratchet system for safe stable hold of the load in any position
- closed gearbox to protect against environmental influence - protection classification IP54
- cable outlet upwards, downwards or at rear
- adjustable crank
- suitable for wall and (optional) floor mounting
- full stainless steel 316 body, drum, crank and all outgoing parts
- corrosion resistant



Options (code)

- grooved drum (GD)
- 2 drum compartment (2D) or multiple up to 8 (XD)
- suitable for floor mounting (FM)
- suitable for Dyneema rope (DY)
- pressure roller (PR)
- ATEX certified zone 2 and 22 (EX)
 - CE II 3G Ex IIC T4 Gc, -20°C<T amb <+70°C
 - CE II 3D Ex IIIC T135°C Dc, -20°C<T amb <+70°C
- custom options possible - [on request](#)

Accessories

- steel, stainless steel or fiber rope ([p. 57](#))
- pulley block ([p. 59](#))
- electric or airmotor as from WW1000 ([p. 63](#))

CE   [Product & instruction video on YouTube](#)

Technical specifications MR500-1500 SST

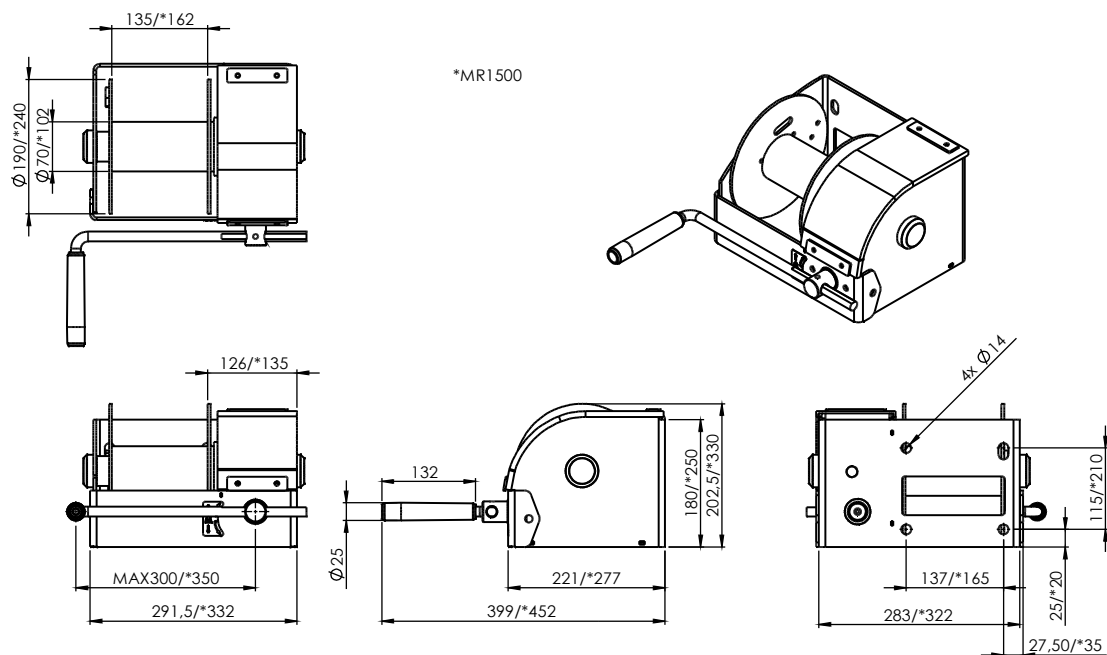

Technical specifications MR3000-5000 SST

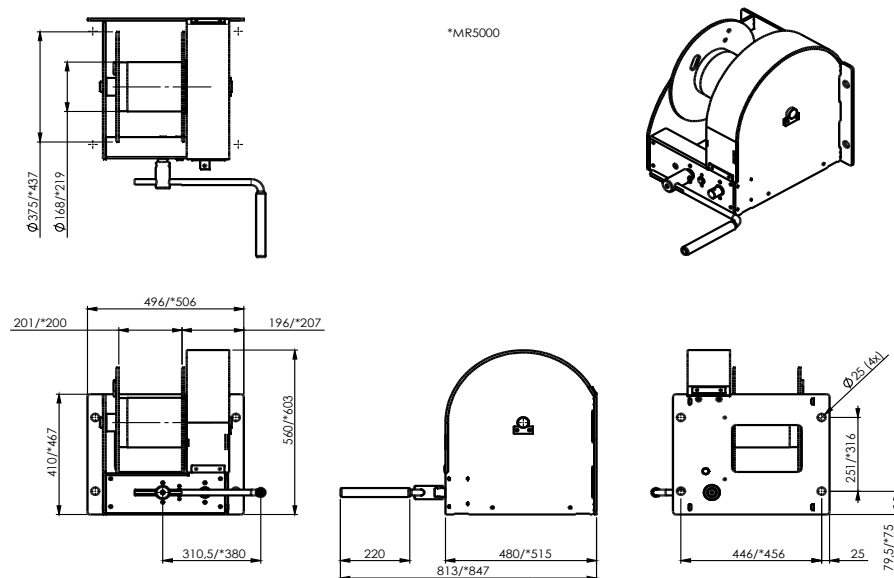

Technical specifications	Unit	MR500 SST	MR1500 SST	MR3000 SST	MR5000 SST
Capacity 1st layer	kg	500	1500	3000	5000
Capacity 4th layer	kg	355	1025	2143	3585
Capacity top layer	kg	224	846	1667	3276
Rope diameter-Ø	mm	6	10	14	18
MBL of cable	kN	15	45	90	160
Rope storage 1st layer	m	4,3	4,2	5,7	5,2
Rope storage 4th layer	m	22,8	24	32,5	31,5
Rope storage top layer	m	78,2	41,3	68,7	42,9
Lifting speed (2nd shaft)	m/min	1,2	0,5	0,7 (0,3)	0,8 (0,2)
Crank effort at full load	kg	10	14	31 (14)	73 (15)
Weight (without rope)	kg	16	30	104	135
Article number	no.	77281367	77281882	77277090	77279090

Theatre winch

300 kg

Description of the winch

The theatre winch is a high-quality and also safe winch that has been specially developed for the theatre and entertainment industry. This winch complies with the new standards for this sector, namely EN17206, and is therefore new in our range. In short, it's a great addition for Gebuwin, which literally and figuratively has the right to be "In The Picture".

Product specifications

- compliant to the EN17206 norm for stage and entertainment industry
- static safety factor 8
- The worm gear transmission has a natural braking effect
- Closed gearbox to prevent accidents
- grooved drum for single-layer storage of wire rope
- two load pressure brakes with double ratchet system for safe stable hold of the load in any position
- equipped with a spring loaded pressure roller for smooth winding on the drum
- cable outlet upwards and downwards
- double wire rope fastening for extra safety
- adjustable and secured crank
- suitable for wall mounting
- 1 layer of paint



Options (code)

- 2 drum compartment (2D)
- increase of drum to store more rope

Accessories

- steel, stainless steel or fiber rope ([p. 57](#))
- pulley block ([p. 59](#))

CE   [Product & instruction video on YouTube](#)

Technical specifications TW300

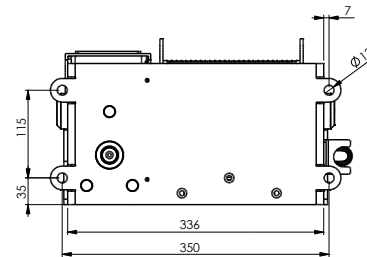
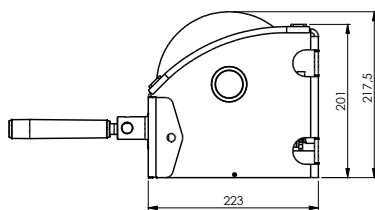
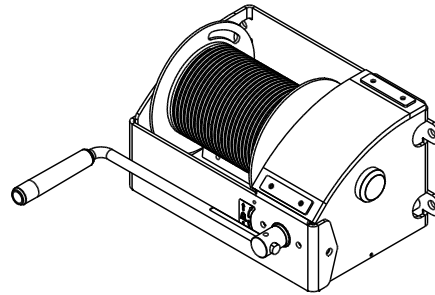
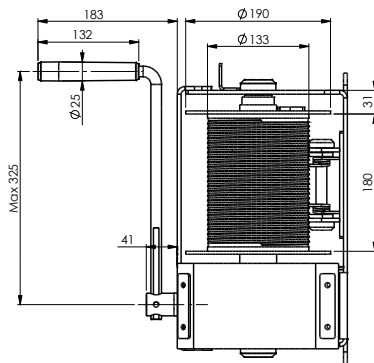

Technical specifications TW300L

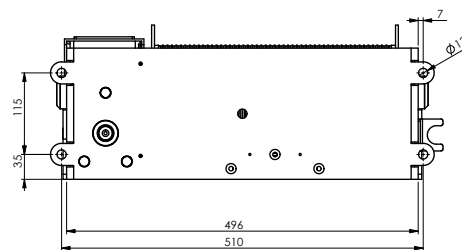
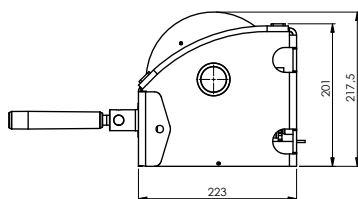
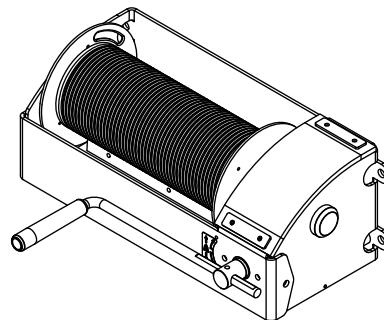
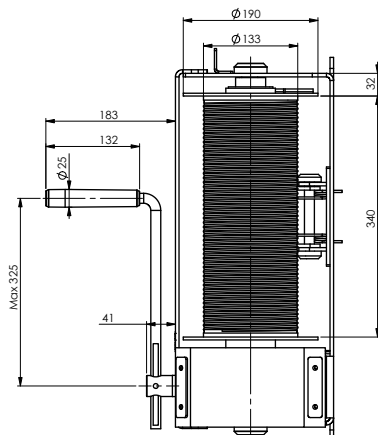

Technical specifications	Unit	TW300	TW300L
Capacity 1st layer	kg	300	300
Rope diameter- \varnothing	mm	6	6
MBL of cable	kN	17	17
Rope storage 1st layer	m	10	20
Lifting speed	m/min	2,3	2,3
Crank effort at full load	kg	15	15
Weight (without rope)	kg	21	25
Article number	no.	77281340	77281341

Spur gear hand winch

150 kg



Description of the winch

This small compact hand-operated winch weighing only 4 kg excels because of its high speed. Its speed and size make it well suited to smaller jobs.

Product specifications

- winch suitable for lifting and pulling in compliance with EN13157
- static safety factor 4
- load pressure brake with double ratchet system for safe stable hold of the load in any position
- cable outlet upwards
- adjustable crank
- suitable for wall mounting
- 1 layer of paint

Options (code)

- zinc-plated finish 6 - 8 micron (EV)
- 2 layers of paint (2L)
- ATEX certified zone 2 and 22 (EX)
 - CE II 3G Ex IIC T4 Gc, -20°C<T amb <+70°C
 - CE II 3D Ex IIIC T135°C Dc, -20°C<T amb <+70°C
- custom options possible - [on request](#)

Accessories

- steel or stainless steel rope ([p. 57](#))
- pulley block ([p. 59](#))

CE Ex  [Product & instruction video on YouTube](#)

Technical specifications TL150

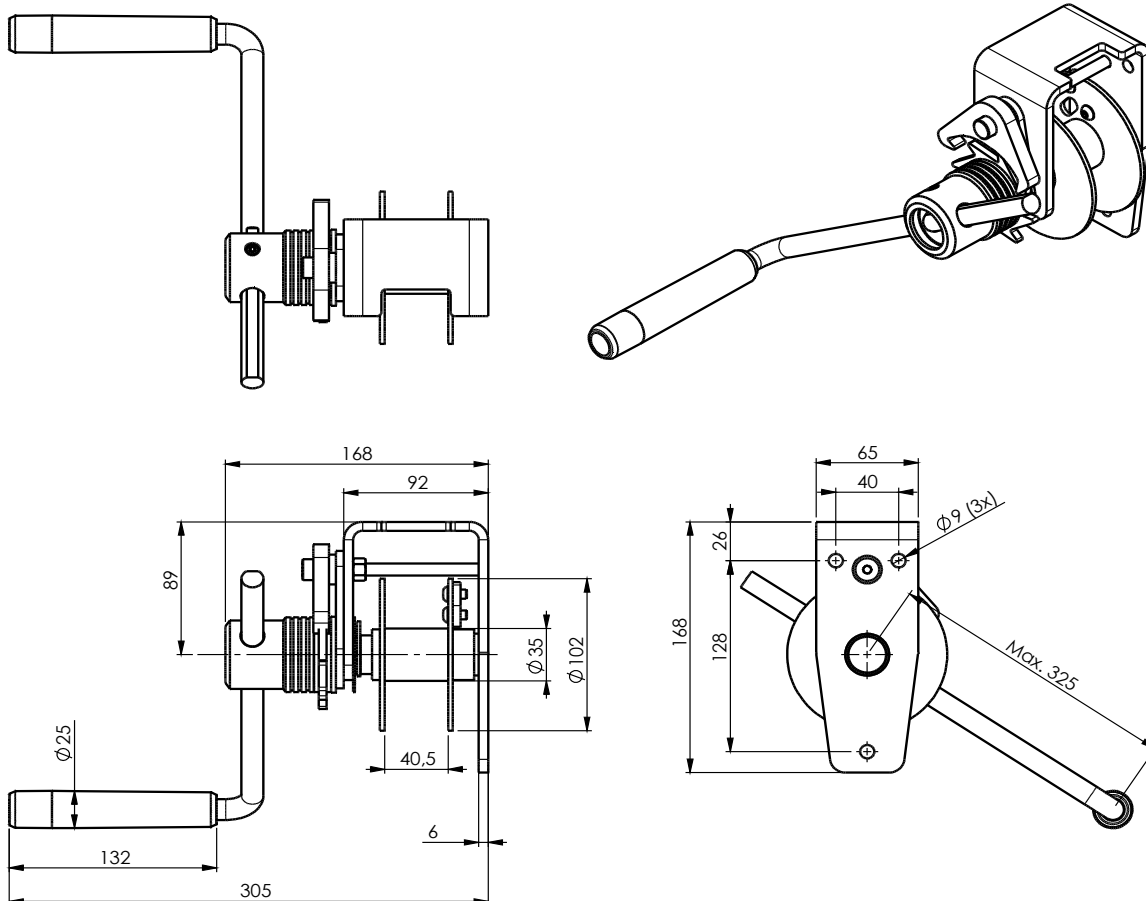

Technical specifications	Unit	TL150
Capacity 1st layer	kg	150
Capacity 4th layer	kg	98
Capacity top layer	kg	67
Rope diameter-Ø	mm	4
MBL of cable	kN	9
Rope storage 1st layer	m	0,7
Rope storage 4th layer	m	4,9
Rope storage top layer	m	13,1
Lifting speed	m/min	7,3
Crank effort at full load	kg	10
Weight (without rope)	kg	4
Article number	no.	77111010

Spur gear hand winch

300 – 600 kg

Description of the winch

This convenient spur gear winch excels by its speed. It is equipped with a load-pressure brake with a double ratchet system and a semi-closed housing. In short, a fine, easy winch!

Product specificaties

- winch suitable for lifting and pulling in compliance with EN13157
- static safety factor 4
- load pressure brake with double ratchet system for safe stable hold of the load in any position
- cable outlet upwards
- adjustable crank
- suitable for wall mounting
- 1 layer of paint





Options (code)

- zinc-plated finish 6 - 8 micron (EV)
- 2 layers of paint (2L)
- ATEX certified zone 2 and 22 (EX)
 - CE II 3G Ex IIC T4 Gc, -20°C<T amb <+70°C
 - CE II 3D Ex IIIC T135°C Dc, -20°C<T amb <+70°C
- custom options possible - [on request](#)

Accessories

- steel or stainless steel rope ([p. 57](#))
- pulley block ([p. 59](#))

CE   [Product & instruction video on YouTube](#)

Technical specifications TL300-600

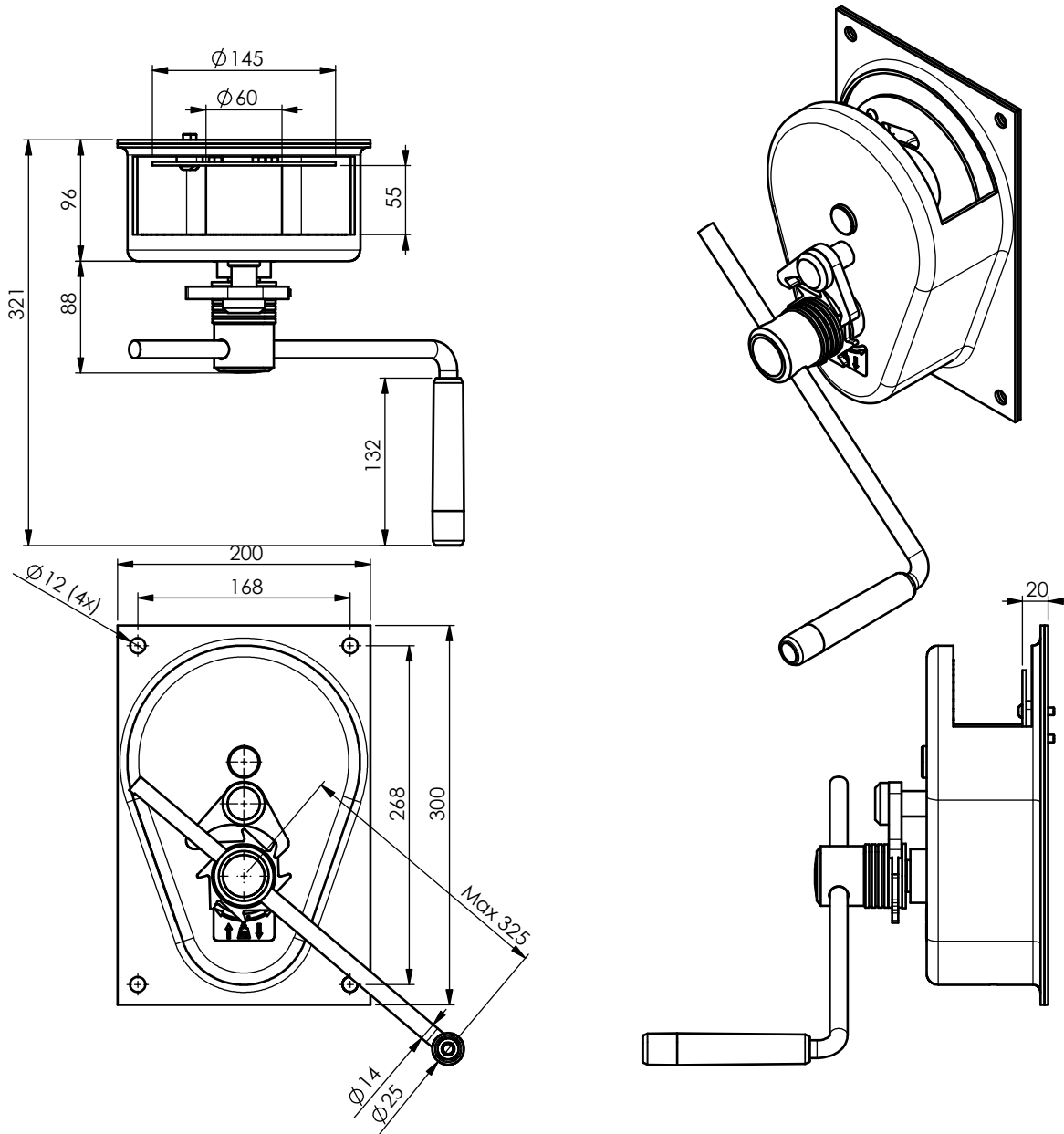

Technical specifications	Unit	TL300	TL600
Capacity 1st layer	kg	300	600
Capacity 4th layer	kg	234	408
Capacity top layer	kg	172	336
Rope diameter-Ø	mm	4	6
MBL of cable	kN	9	17
Rope storage 1st layer	m	2,3	1
Rope storage 4th layer	m	12,5	7
Rope storage top layer	m	35,4	12,3
Lifting speed	m/min	1,9	1,7
Crank effort at full load	kg	5,5	10
Weight (without rope)	kg	10	11
Article number	no.	77121000	77131000

Spur gear hand winch

1000 – 1500 kg



Description of the winch

This spur gear winch is fast, easy and can be mounted on both walls and floors. The free spool option is therefore also available for this winch. In addition to IP54 water resistance, this winch is also available in stainless steel 304.

Product specifications

- winch suitable for lifting and pulling in compliance with EN13157
- static safety factor 4
- protection classification IP54
- load pressure brake with double ratchet system for safe stable hold of the load in any position
- cable outlet upwards, downwards or at the left
- closed gearbox to protect against environmental influence
- adjustable crank
- suitable for wall and floor mounting
- 1 layer of paint



Options (code)

- zinc-plated finish 6 - 8 micron (EV)
- 2 layers of paint (2L)
- stainless steel grade 304 (SST304)
- 2 drum compartment (2D)
- free-spooling device for pulling applications. To disengage the drum (FS)
- ATEX certified zone 2 and 22 (EX)
 - CE II 3G Ex IIC T4 Gc, -20°C<T amb <+70°C
 - CE II 3D Ex IIIC T135°C Dc, -20°C<T amb <+70°C
- custom options possible - [on request](#)

Accessories

- steel or stainless steel rope ([p. 57](#))
- pulley block ([p. 59](#))



[Product & instruction video on YouTube](#)

Technical specifications TL1000-1500

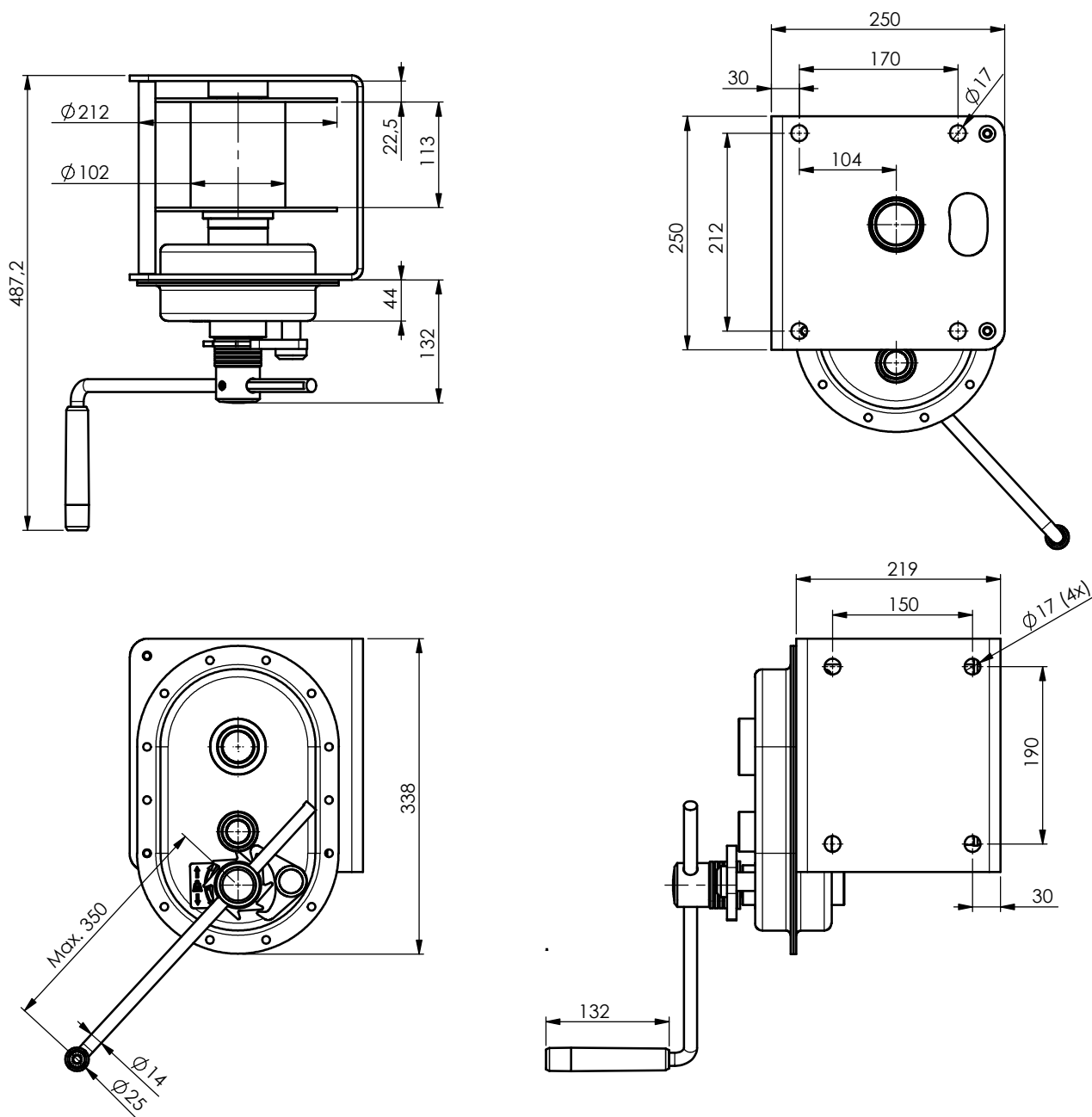

Technical specifications	Unit	TL1000	TL1500
Capacity 1st layer	kg	1000	1500
Capacity 4th layer	kg	726	1025
Capacity top layer	kg	614	927
Rope diameter- \varnothing	mm	8	10
MBL of cable	kN	34	51
Rope storage 1st layer	m	3,5	2,5
Rope storage 4th layer	m	19,5	15,4
Rope storage top layer	m	33	21
Lifting speed	m/min	1,2	0,8
Crank effort at full load	kg	11	12
Weight (without rope)	kg	27	27,5
Article number	no.	77141000	77151100

Console winch CW500

500 kg



Description of the winch

This spur gear winch is fast (2,2 m/min), easy and can be mounted on both walls and floors. The free spool option makes it possible to disengage the drum from the winch to pull out the wire quick. In addition to IP54 water resistance, this winch is also available in stainless steel 316.

These are preliminary images and data. Final ones will follow in January

Product specifications

- winch suitable for lifting and pulling in compliance with EN13157
- static safety factor 4
- protection classification IP54
- load pressure brake with double ratchet system for safe stable hold of the load in any position
- cable outlet upwards, downwards or at the left
- closed gearbox to protect against environmental influence
- free spool - to disengage the drum
- adjustable crank
- suitable for wall and floor mounting
- 1 layer of paint

Options (code)

- zinc-plated finish 6 - 8 micron (EV)
- stainless steel grade 316
- ATEX certified zone 2 and 22 (EX)
 - CE II 3G Ex IIC T4 Gc, -20°C<T amb <+70°C
 - CE II 3D Ex IIIC T135°C Dc, -20°C<T amb <+70°C
- custom options possible - [on request](#)

Accessories

- steel or stainless steel rope ([p. 57](#))
- pulley block ([p. 59](#))

CE   [Product & instruction video on YouTube](#)

Technical specifications CW500

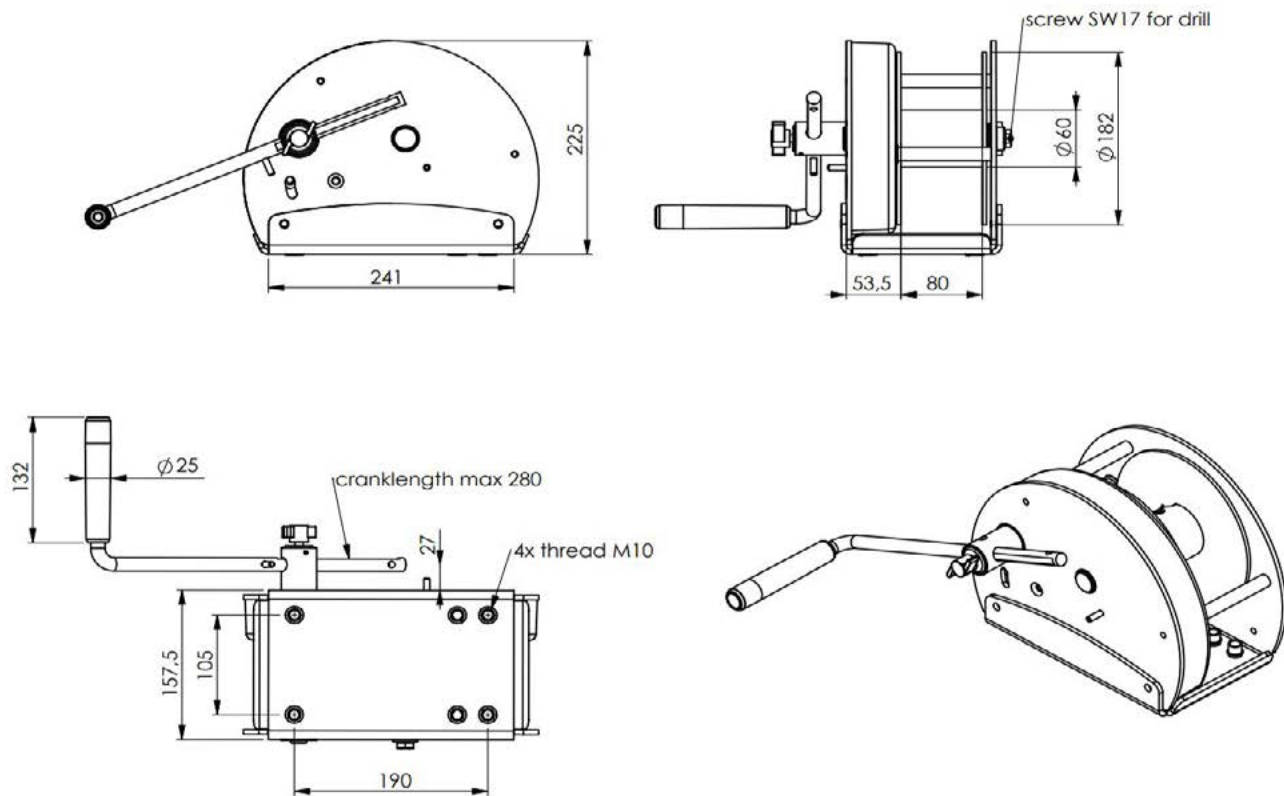

Technical specifications	Unit	CW500
Capacity 1st layer	kg	500
Capacity 4th layer	kg	340
Capacity top layer	kg	400
Rope diameter-Ø	mm	6
MBL of cable	kN	17
Rope storage 1st layer	m	2
Rope storage 4th layer	m	11
Rope storage top layer	m	40
Lifting speed	m/min	2,2
Crank effort at full load	kg	11
Weight (without rope)	kg	13,7
Article number	no.	77155130

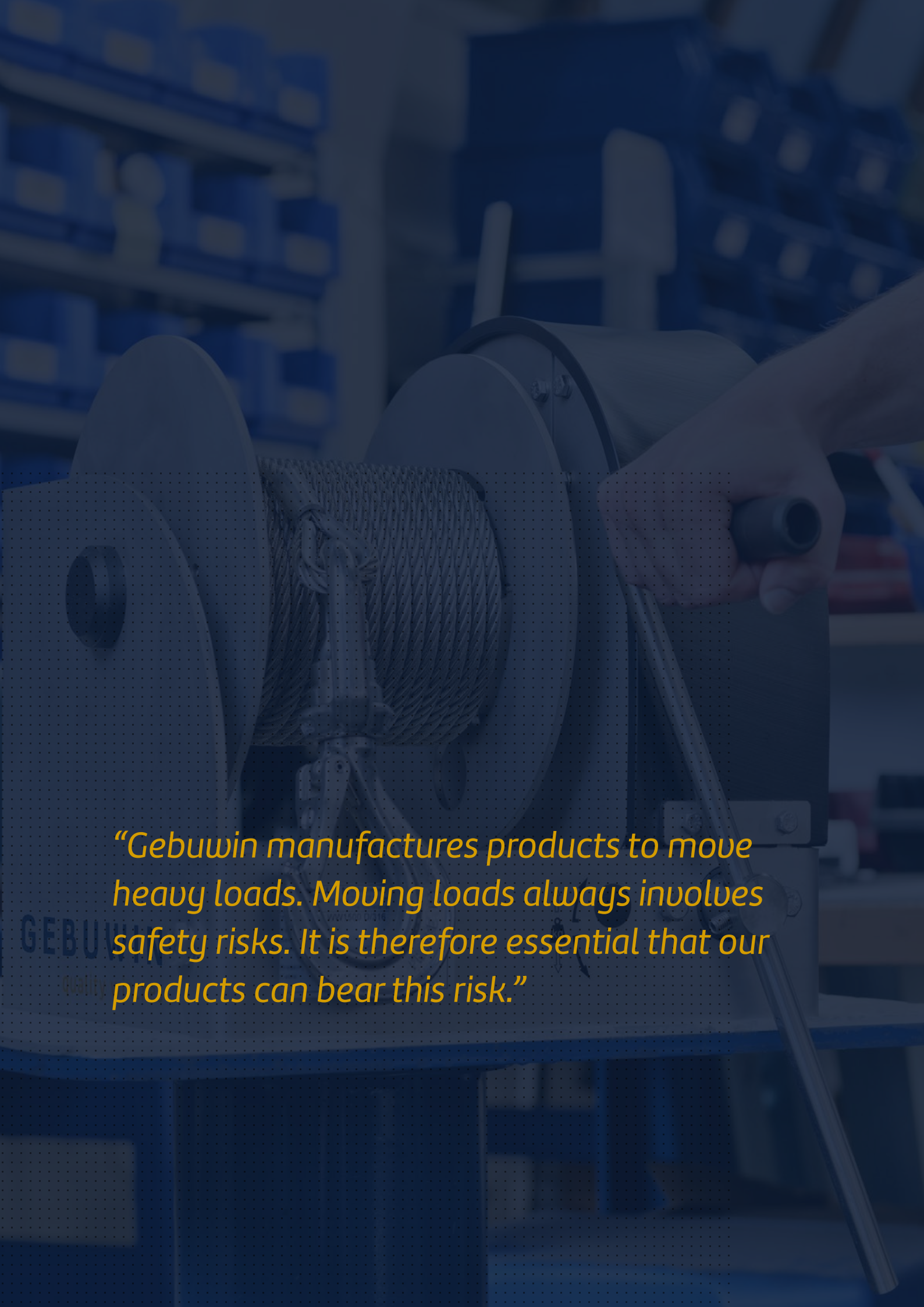
A person is operating a large industrial machine, likely a wire drawing or spooling machine, in a factory setting. The machine has a large spool of wire and a hand crank. The background shows industrial equipment and a blue wall. The text is overlaid on the image in a yellow, italicized font.

“Gebuwin manufactures products to move heavy loads. Moving loads always involves safety risks. It is therefore essential that our products can bear this risk.”

GEBUWIN
Quality

Electric winches

Our electric winches are designed for both light and very heavy loads. Gebuwin produces two types of electric winches. Our product range includes electric worm-gear winches and electric planetary winches. Both winches are compact and have a robust construction. The electric worm-gear winches have a capacity of up to 3200 kg and the planetary winches can handle up to 30 tonnes.



Index

- Electric e-Winch p. 31
- Electric worm gear winch p. 33
- Low speed electric winch p. 35

Electric e-Winch

250 – 3000 kg

Description of the winch

Newly developed electric pulling and lifting electric winch with a powerful three-phase motor, budget-friendly and strong in its work.

Product specifications

- winch suitable for lifting and pulling
- maintenance free bearings
- protection classification IP54, insulation class F
- standard overload protection as from 1000 kg
- powerful three-phase motor for multirange voltage:
 - 230 – 400V / 50 Hz - three phase
 - 480V / 60 Hz (torque -20%, speed +20%)
- 1 speed pendant control with 1m cable
- standard 2 meter power cable including 16A CEEplug
- 1 layer of paint

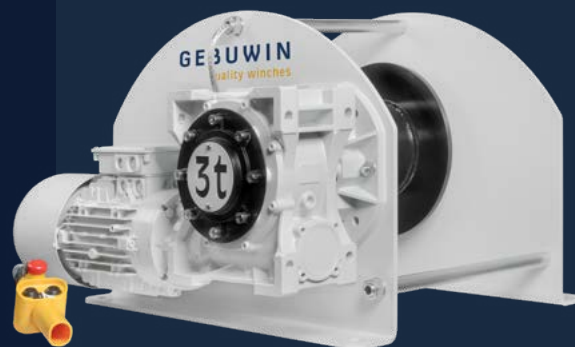

Options (code)

- limit switch - required for lifting applications (LS)
- pressure roller (PR)
- grooved drum (GD)
- 2 drum compartment (2D) or multiple up to 8 (XD)
- external limit switch (EL)
- protection classification IP55 (IP55)
- increase of cable storage - [on request](#)
- custom options possible - [on request](#)

Accessories

- steel, stainless steel or fiber rope ([p. 57](#))
- pulley block ([p. 59](#))

CE Ex  [Product & instruction video on YouTube](#)

Technical specifications e-W250-3000

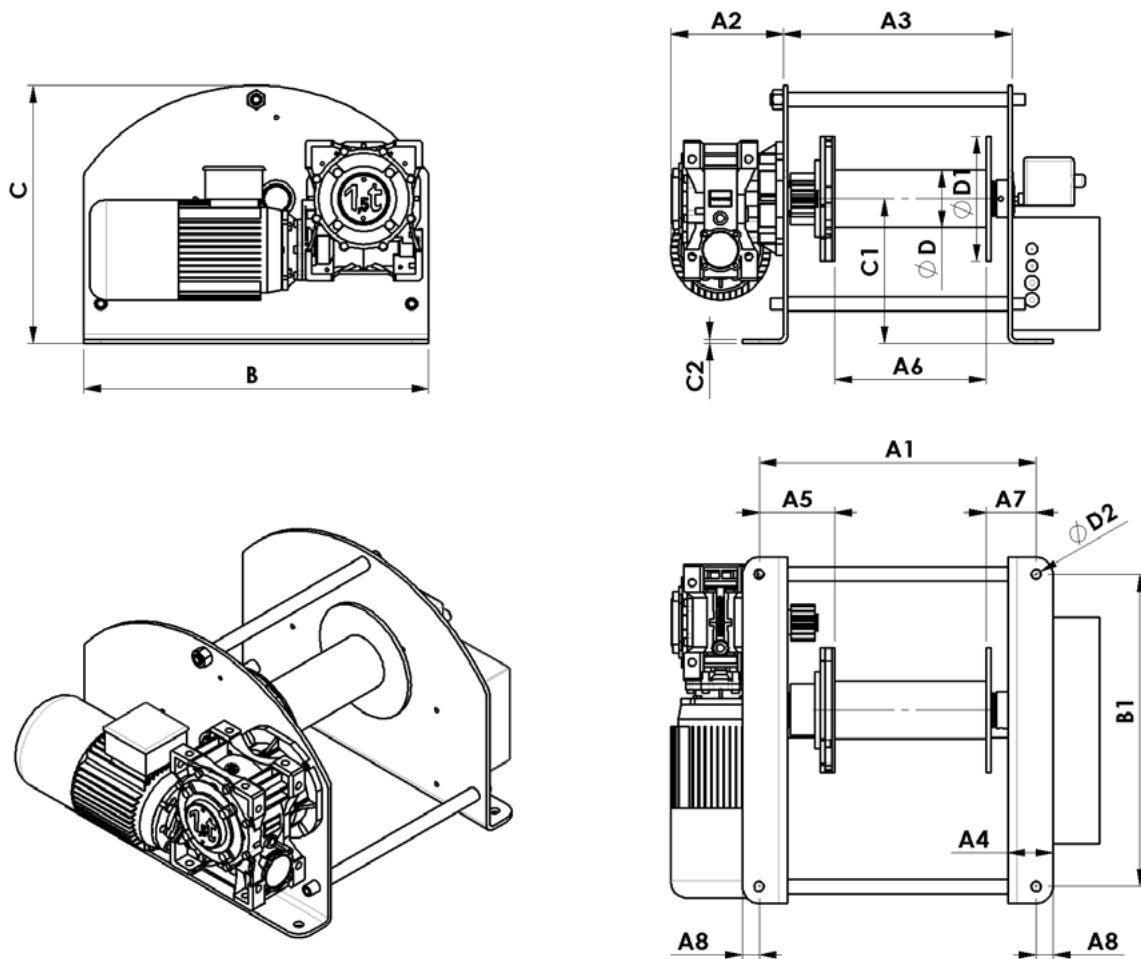

Dimensions (mm)	A1	A2	A3	A4	A5	A6	A7	A8	B	B1	C	C1	C2	D	D1
<u>e-W250</u>	269	151	222	47	59	146	64	17	550	440	355	190	6	55	150
<u>e-W500</u>	269	189	222	47	59	146	64	17	550	440	355	190	6	55	150
<u>e-W1000</u>	475	172	405	70	130	265	80	27	610	500	455	255	8	102	220
<u>e-W1500</u>	475	211	405	70	130	265	80	27	610	500	455	255	8	102	220
<u>e-W2000</u>	475	220	405	70	149	238	85	27	700	570	515	260	8	133	325
<u>e-W3000</u>	475	240	405	70	149	241	85	27	700	570	515	260	8	168	325

Technical specifications	Unit	e-W250	e-W500	e-W1000	e-W1500	e-W2000	e-W3000
Capacity 1st layer	kg	250	500	1000	1500	2000	3000
Capacity top layer (layers)	kg	109 (12)	247 (7)	570 (7)	927 (5)	998 (8)	1957 (5)
Lifting speed	m/min	5,2	5,4	3,5	4,4	4,7	3,6
Rope diameter-Ø	mm	4	6	8	10	12	14
MBL of cable	kN	9	18	36	36	70	114
Rope storage 1st layer	m	5,7	3,8	9,7	7,7	6,8	7,4
Rope storage top layer	m	122	45	100	55	94	54
Motor output (400V)	kW	0,37	0,75	1,1	1,8	2	3
Current (400V)	A	1	2	2,5	4,6	6,4	6,4
FEM 9.511 classification	FEM	1Bm	1Bm	1Cm	1Cm	1Cm	1Cm
Weight (without rope)	kg	52	60	107	122	180	192
*limit switch required for lifting							

Electric worm gear winches

125 – 3200 kg

Description of the winch

This electric winch is part of Gebuwin's well-known product range. A very robust and safe winch. This winch is suitable for both lifting and pulling and has an IP55 rating. It is a real industrial winch with its high FEM values of at least 1CM or higher. Strong workmanship, robust efficient winch that is very friendly in use.

Product specifications

- winch suitable for lifting and pulling
- maintenance free ball bearings
- protection classification IP55, insulation class B
- standard overload protection starting from 1000 kg
- standard 1 meter pendant control switch
- operation mode S3-40% - 120 c/h
- 1 layer of paint

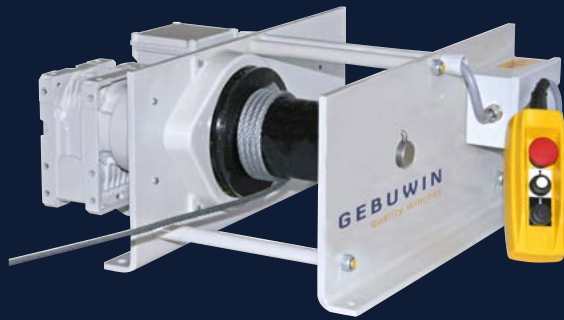

Options (code)

- available in 230/400V three phase and 230V single phase
- available as electric lifting winch (limitswitch and low voltage control are required)
- increase of cable storage per 10 m up to 90m
- grooved drum (GD)
- multiple cable drum compartments (XD)
- disengaging clutch (except for 125 kg model)
- wall mounted control switch
- low voltage control 42 V control
- double speed
- radio control (RC)
- frequency control
- protection classification up to IP66
- ATEX certified (EX)

Accessories

- steel or stainless steel rope ([p. 57](#))
- pulley block ([p. 59](#))

CE Ex  [Product & instruction video on YouTube](#)

Technical specifications EW125-3200

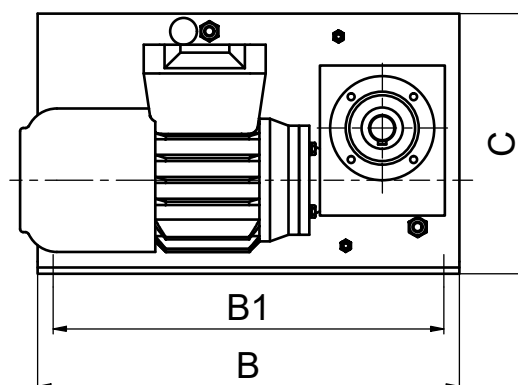
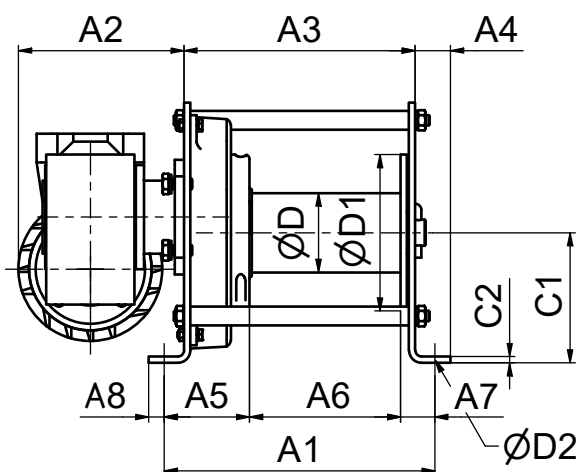

Dimensions (mm)	A1	A2	A3	A4	A5	A6	A7	A8	B	B1	C	C1	C2	D	D1	D2
EW125	205	195/165	171	30	4	135	27	13	405	375	215	140	4	60	130	9
EW250	260	195/165	222	34	78	150	32	15	405	375	250	125	6	60	150	11
EW500	260	195/165	222	34	82	145	33	15	405	375	250	125	6	76	150	11
EW1000	345	240/216	289	45	99	198	48	17	575	535	270	155	10	108	180	13
EW2000	440	240/216	358	61	173	200	67	20	600	550	385	171	15	146	245	17
EW3200	525	198	443	61	193	257	75	20	600	550	405	191	15	216	370	17

Technical specifications	Unit	EW125	EW250	EW500	EW1000	EW2000	EW3200
Capacity 1st layer	kg	125	250	500	1000	2000	3200
Capacity top layer	kg	90	180	340	780	1560	2500
Lifting speed	m/min	7,8	5	2,5	4,5	4,5	4,5
Rope diameter-Ø	mm	4	4	6	8	11	16
MBL of cable	kN	5	9	18	36	70	114
Rope storage 1st layer	m	6,4	7,1	5,7	8,4	8	9
Rope storage top layer	m	32	35	30	30	30	37
Motor output (230 V)	kW	0,37	0,37	0,37	1,3	2,6	-
Motor output (400 V)	kW	0,37	0,37	0,37	1,3	2,6	3
Current (230 V)	A	4	4	4	9,1	9,1	-
Current (400 V)	A	1,1	1,1	1,1	3,2	6	7
Weight (without rope)	kg	27	37	40	88	160	210

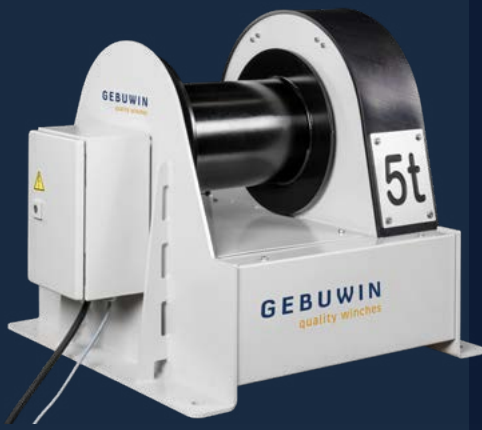

Low speed electric winch LS5000

5000 kg

Description of the winch

Low-speed electric winch, made to move fragile loads from 0,3 metres per minute, powerful with its 5 ton lifting capacity in combination with a 230V connection.

Product specifications

- robust and safe electric pulling and lifting winch 400 V / 230 V
- in compliance with EN 14492
- protection classification electric IP55 / mechanical IP54
- mechanical overload protection
- thermal protection electric motor
- low voltage (24 V) pendant switch with 2 m cable
- including 2 m power cable with 16A CEE plug
- automatic grease system for the worm gearing
- 1 layer of paint



Options (code)

- limit switch - required for lifting applications (LS)
- grooved drum (GD)
- 230V - 50Hz

Accessories

- steel, stainless steel or fiber rope ([p. 57](#))
- pulley block ([p. 59](#))

CE   [Product & instruction video on YouTube](#)

Technical specifications LS5000

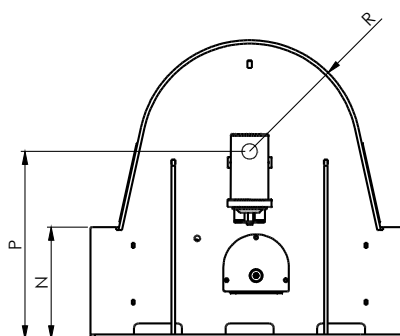
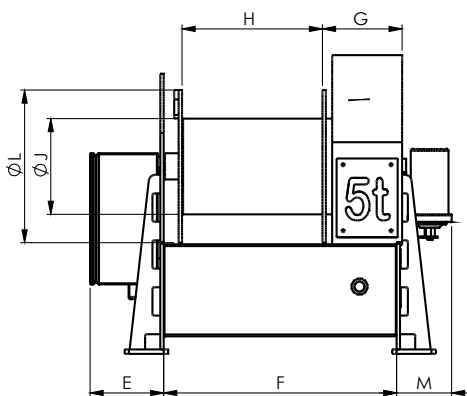
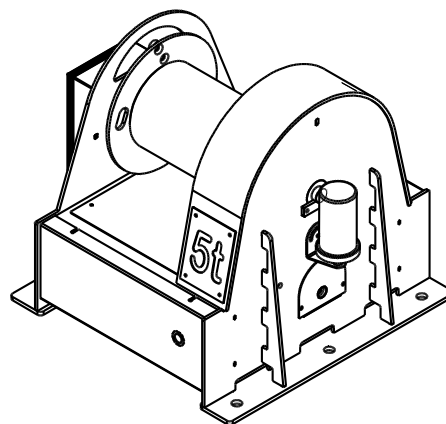
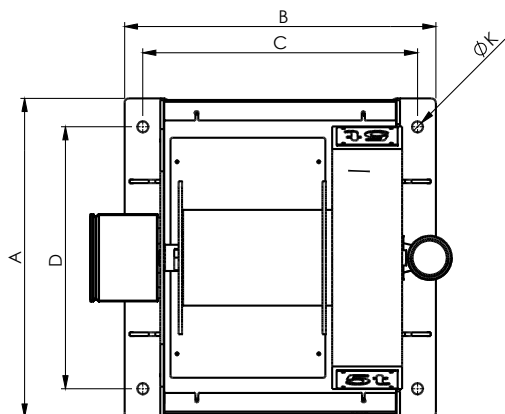

Dimensions (mm)	A	B	C	D	E	F	G	H	J	K	L	M	N	P	R
LS5000	730	704	630	600	169	534	183	322	219	25	351	126	254	427	255

Technical specifications	Unit	LS5000
Capacity 1st layer	kg	5000
Capacity top layer	kg	3959
Lifting speed	m/min	0,4
Rope diameter- \varnothing	mm	18
MBL van kabel	kN	150
Rope storage top layer (pulling)	m	39
Rope storage top layer (lifting)	m	10
Motor output	kW	0,75
Current	A	2
Weight (without rope)	kg	216



GEBUWIN
quality winches

“The e-Winch is truly one of Gebuwin’s eye catchers. A truly robust winch that has been re-released this year by Gebuwin and in which the team of engineers have applied all of today’s innovations.”

Battery drill winches

In the situations where a load needs to be moved and no electricity is available one can use a manual winch. But moving a load manually is not always desirable. That is why Gebuwin has developed winches that can be operated with a 'normal' cordless drill machine. These drill winches can lift up to 1000 kg of load.



Index

- Drill winch DW1000 p. 41
- Battery Drill winch WA200 p. 43
- Pulley Man PM300-600 p. 45

Battery drill winch DW1000

1000 kg



Description of the winch

The worm gear winch can be operated both manually and with a cordless drill. A user-friendly winch and often used as a back-up system. If there is a power failure and you want to move a heavy load quickly and effectively, the use of a battery-powered drill offers a solution. The winch is equipped with automatic grease lubrication and a special flexible adaptor to absorb the vibrations of the drilling machine and keep the winch in good condition.

Product specificaties

- winch suitable for lifting and pulling in compliance with EN13157
- static safety factor 4
- load pressure brake with double ratchet system for safe stable hold of the load in any position
- cable outlet upwards, downwards or at rear
- protection classification IP54
- automatic grease system for the worm gearing
- adjustable crank
- drill and hand operated
- suitable for wall and (optional) floor mounting
- 1 layer of paint

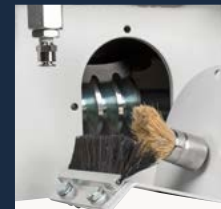

Options (code)

- zinc-plated finish 6 - 8 micron (EV)
- 2 layers of paint (2L)
- grooved drum (GD)
- 2 drum compartment (2D) or multiple up to 8 (XD)
- suitable for floor mounting (FM)
- custom options possible - [on request](#)

Accessories

- steel, stainless steel or fiber rope ([p. 57](#))
- pulley block ([p. 59](#))



[Product & instruction video on YouTube](#)

GEBUWIN
quality winches

Industrieweg 6, 7102 DZ Winterswijk, The Netherlands
Telephone: +31(0)543 532600 Email: info@gebuwin.com

For more information, visit: www.gebuwin.com

Technical specifications DW1000

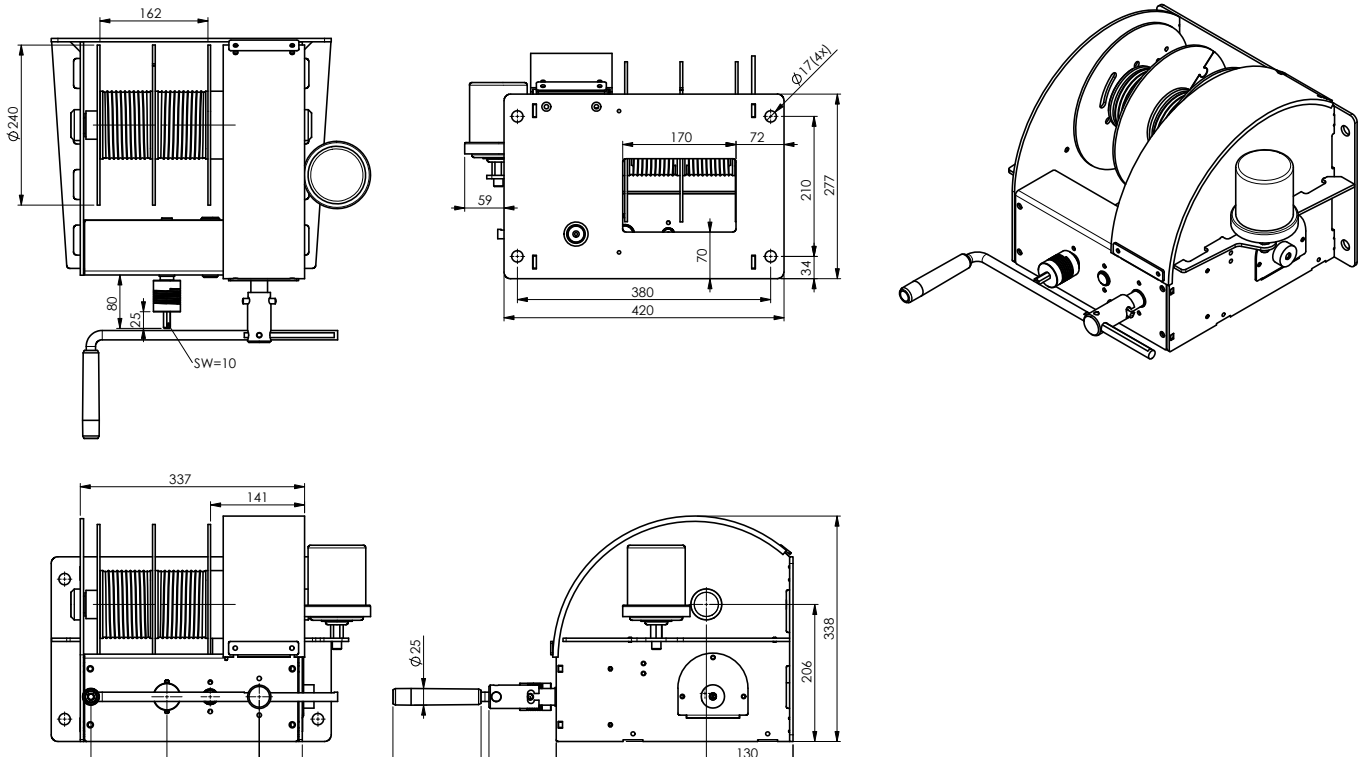

Technical specifications	Unit	DW1000
Capacity 1st layer	kg	1000
Capacity 4th layer	kg	725
Capacity top layer	kg	527
Rope diameter- \varnothing	mm	8
MBL of cable	kN	30
Rope storage 1st layer	m	5,5
Rope storage 4th layer	m	29,2
Rope storage top layer	m	73
Lifting speed	m/min	0,5
Crank effort at full load	kg	11
Torque ingoing shaft	Nm	6
Max. input rotation speed drill	rpm	650
Weight (without rope)	kg	39
Article number	no.	77290005

Battery drill winch

200 kg



Description of the winch

This battery drilling machine winch is a user-friendly winch and is often used as a back-up system. If the power fails and you want to move a heavier load quickly and effectively, the use of a battery powered drill offers a solution. The winch is very compact and can be mounted both against the wall and on the floor. Ideal for smaller work.

Product specifications

- robust and safe lifting and pulling winch operated with battery drill
- static safety factor 4
- flexible coupling attachment for battery drill
- self braking worm gear system
- suitable for wall or floor (console) mounting
- suitable for short lifting lengths
- maintenance free aluminum closed gear box
- in compliance with EN13157 and DIN 15020
- 1 layer of paint

Accessories

- steel, stainless steel or fiber rope ([p. 57](#))
- pulley block ([p. 59](#))

CE   [Product & instruction video on YouTube](#)

Technical specifications WA200

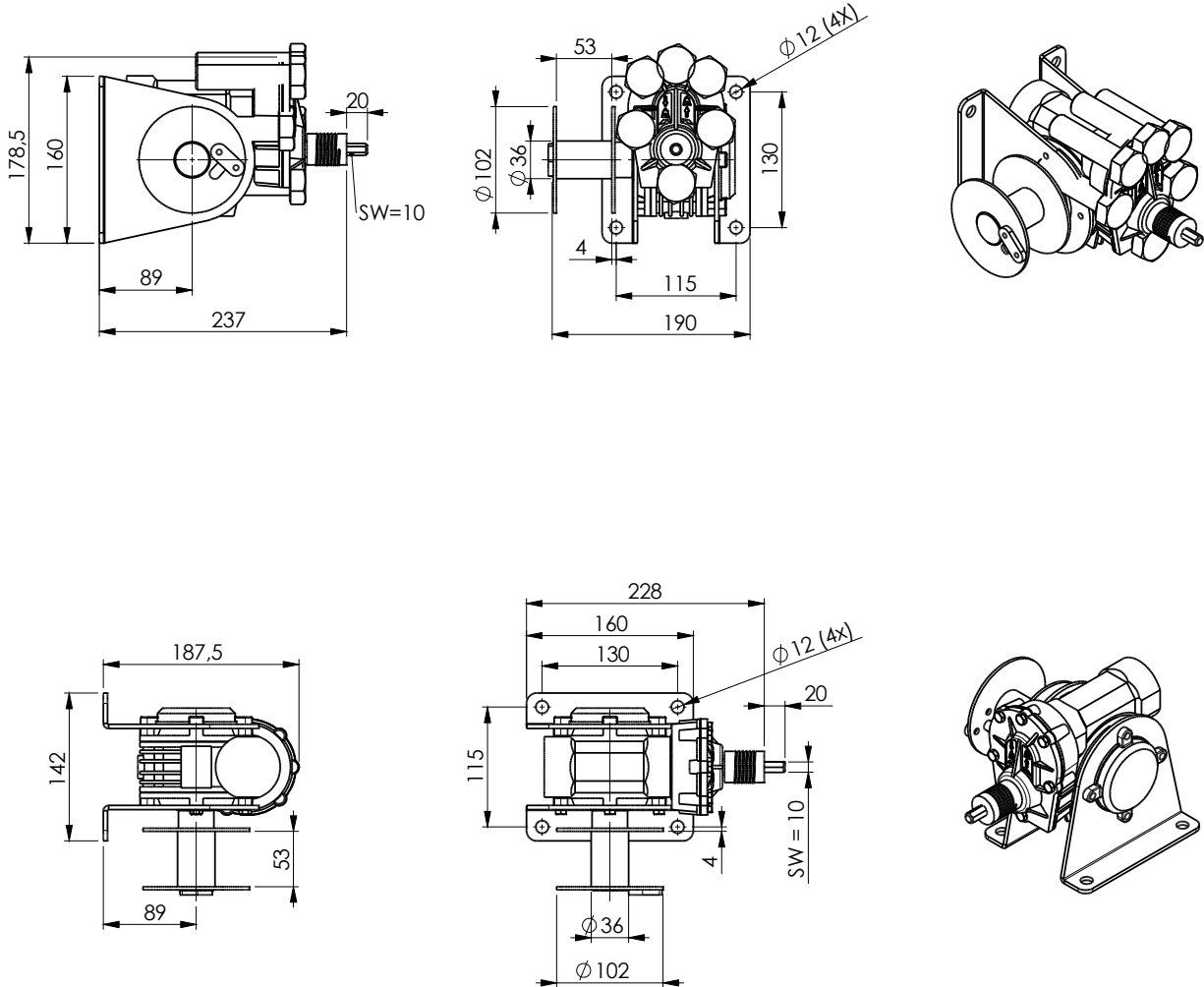

Technical specifications	Unit	WA200
Capacity 1st layer	kg	200
Capacity top (7) layer	kg	90
Rope diameter-Ø	mm	4
MBL of cable	kN	9
Rope storage 1st layer	m	1
Rope storage top layer	m	18
Max. input rotation speed drill	rpm	1400
Lifting speed	m/min	0,8
Weight (without rope)	kg	6

Pulley Man

300 – 600 kg

Description of the winch

The Pulley Man, with its 4 kg, is easy to carry. This winch can be installed in three ways, rotates 360 degrees and has an infinite cable. In short, this Pulley Man may not be missing in your workshop.

Product specifications

- Light weight and portable
- Suitable to lift loads up to 600 kg (PM600)
- Suitable to pull loads up to 3000 kg
- Can be used with a cordless drill and power drill
- Possible to rotate the load 360°
- Standard rope length 12 meters (possible up to 100 meters)
- Patented self-braking reduction brake
- 1 layer of paint



Options (code)

- Available in complete kit including:
 - Robust case with foam
 - L: 457 W: 367 H: 183 - Brand: Explorercase
 - Cordless drill 18V - 50 Nm - Brand: Hikoki
 - 2 Li-ion batteries 18V - 2,5 Ah - Brand: Hikoki
 - 1 charger - Brand: Hikoki
 - 2 shackles type G-210 - Brand: Crosby
 - 1 sling, length 1 m



[Product & instruction video on YouTube](#)

GEBUWIN
quality winches

Industrieweg 6, 7102 DZ Winterswijk, The Netherlands
Telephone: +31(0)543 532600 Email: info@gebuwin.com

For more information, visit: www.gebuwin.com

Technical specifications PM300-600

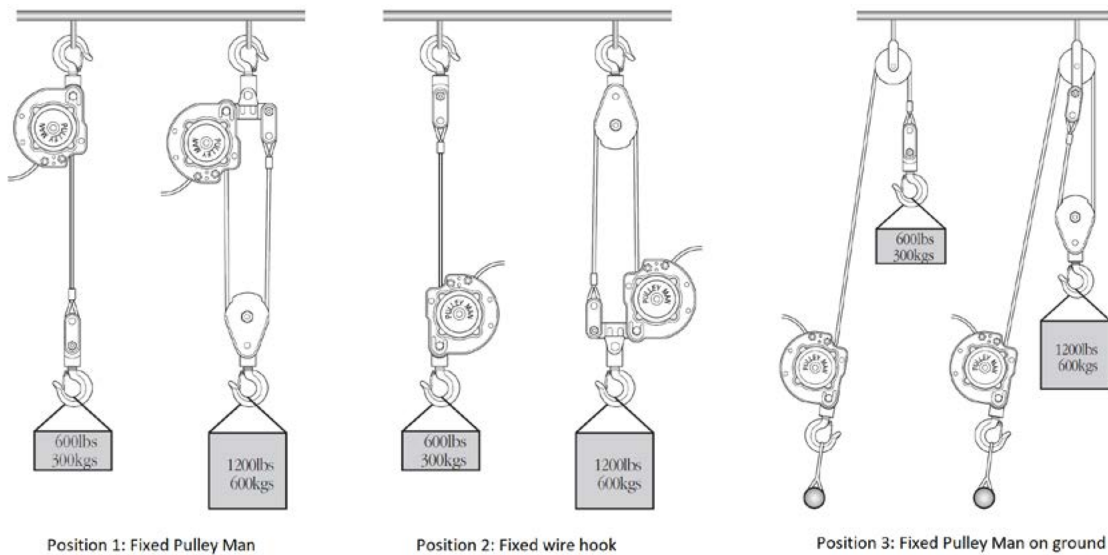
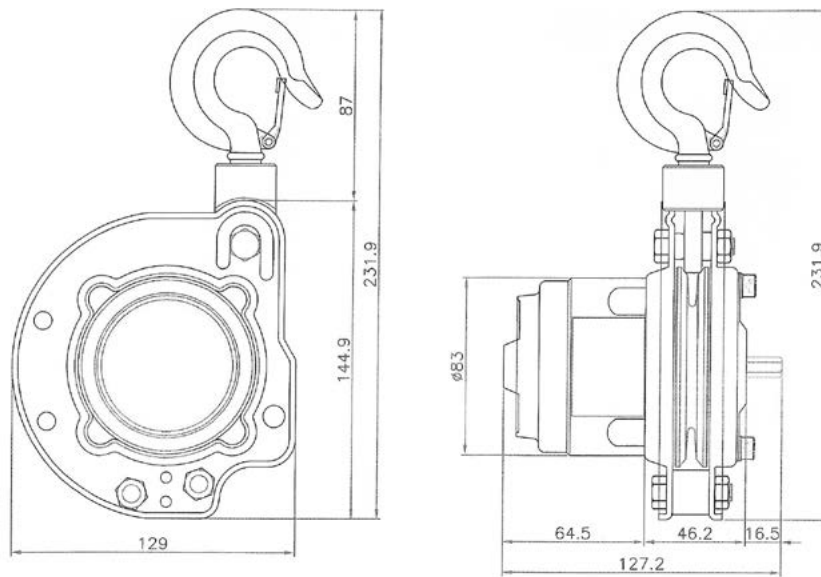

Technical specifications	Unit	PM300	PM600
Lifting capacity	kg	300	600
Pulling capacity (load on wheels, 6° sope)	kg	1500	3000
Pulling capacity (load on wheels, 35° sope)	kg	450	900
Number of falls	nr	1	2
Line speed (no load)	m/min	8	3,75
Line speed (full load)	m/min	6	3
Wire rope diameter	mm	4,76	4,76
Standard rope length with hook	m	12	12
Weight (without rope)	kg	3,8	4,1
Weight incl. rope	kg	5	6
Weight complete kit	kg	9,5	10
Article number	no.	77410001	77410002



GEBUWIN
quality winches

“The DW1000 can be operated both manually and with a cordless drill. A userfriendly winch and often used as a back-up system. If there is a power failure and you want to move a heavy load quickly and effectively, the use of a battery drill offers a solution.”

Swivel davit cranes

Gebuwin has developed a modern designed swivel davit crane especially for lifting goods on location. This davit crane helps you to carry out your work efficiently without the risk of physical strain. The lifting davit is lightweight and is therefore ready for use within a few seconds thanks to the folding system of the boom. When the davit is placed in the accompanying floor socket, it can rotate 360 degrees. Gebuwin produces three types of lifting davits, which vary in lifting capacity and length of the boom. Because of the integrated winch and cable, the davit is not only compact but also low-maintenance. The crank is also adjustable in length so that the hoisting speed can be adjusted.



Index

- Swivel davit cranes p. 49
- Swivel davit cranes SST p. 51
- Swivel davit crane 501
- Swivel davit 2 meter reach p. 49

Swivel davit crane

125 – 500 kg

Description of the winch

The Swivel Davit is a very user-friendly standing crane. Lightweight and portable. Within 3 seconds this davit is ready for use. The integrated winch and cable provide an ergonomic and modern look.

Product specifications

- robust and safe lifting davit crane in compliance with EN13157
- ready to use in 5 seconds
- integrated winch and cable in a modern design
- easy to transport
- load pressure brake with double ratchet system for safe stable hold of the load in any position
- possible to rotate 360° due to the use of ball bearings
- adjustable crank
- including 13 meter wire rope (d5 mm) with hook
- 1 layer of paint

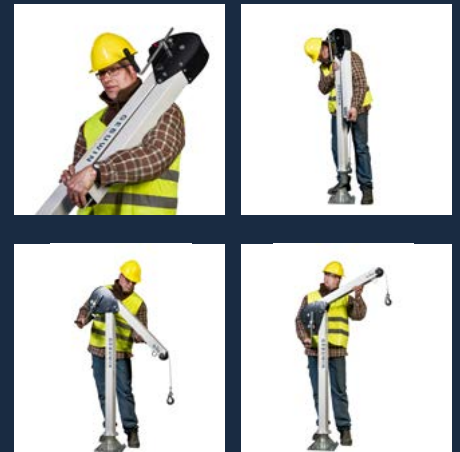

Options (code)

- zinc-plated finish 6 - 8 micron (EV)
- made out of stainless steel 316 ([p. 49](#))
- ATEX certified zone 2 and 22 (EX)
 - CE II 3G Ex IIC T4 Gc, -20°C<T amb <+70°C
 - CE II 3D Ex IIIC T135°C Dc, -20°C<T amb <+70°C
- custom options possible - [on request](#)

Accessories

- floor, wall and in-concrete sockets
- carry bag and protection cover

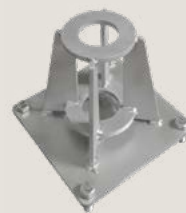

CE   [Product & instruction video on YouTube](#)

GEBUWIN
quality winches

Industrieweg 6, 7102 DZ Winterswijk, The Netherlands
Telephone: +31(0)543 532600 Email: info@gebuwin.com

For more information, visit: www.gebuwin.com

Technical specifications SD125-500

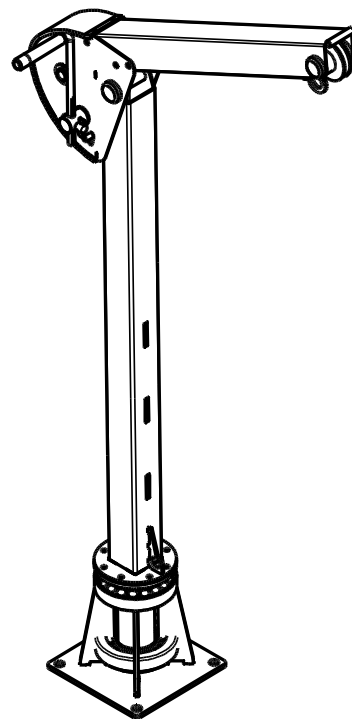
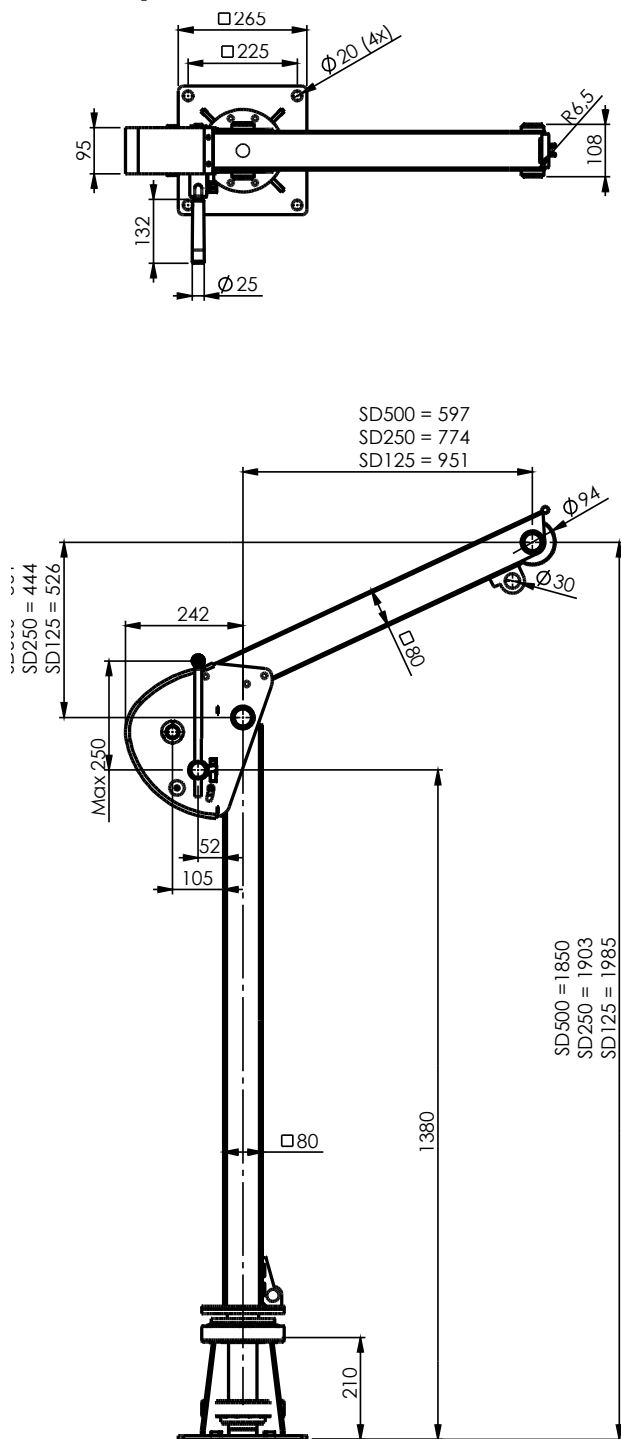

Technical specifications	Unit	SD125	SD250	SD500
Reach	cm	951	774	597
Capacity 1st layer	kg	125	250	500
Capacity top layer	kg	125	250	500
Max. rope storage top layer*	m	18	18	13
Lifting speed	m/min	1,2	1,2	1,2
Crank effort at full load	kg	6	8	10
Weight Swivel Davit	kg	30	30	30
Weight floor-socket	kg	8,9	8,9	8,9
Article number	no.	77001890	77001870	77001850

*standard delivered with 13m cable

Swivel davit crane SST

125 – 500 kg



Description of the winch

The lifting davit stainless steel 316 is a very user-friendly standing crane. Lightweight and portable. Within 3 seconds this winch is ready for use. Due to the use of 316 stainless steel, the Davit crane has a very high corrosion resistance.

Product specifications

- robust and safe lifting davit crane in compliance with EN13157
- ready to use in 5 seconds
- integrated winch and cable in an ergonomic modern design
- easy to transport
- load pressure brake with double ratchet system for safe stable hold of the load in any position
- possible to rotate 360° due to the use of ball bearings
- adjustable crank
- including 13 meter stainless steel wire rope (d5 mm) with hook
- full stainless steel grade 316 body



Options (code)

- ATEX certified zone 2 and 22 (EX)
 - CE II 3G Ex IIC T4 Gc, -20°C<T amb <+70°C
 - CE II 3D Ex IIIC T135°C Dc, -20°C<T amb <+70°C
- custom options possible - [on request](#)

Accessoires

- floor, wall and in-concrete sockets
- carry bag and protection cover

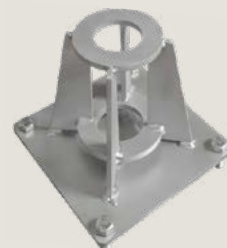

CE Ex  [Product & instruction video on YouTube](#)

GEBUWIN
quality winches

Industrieweg 6, 7102 DZ Winterswijk, The Netherlands
Telephone: +31(0)543 532600 Email: info@gebuwin.com

For more information, visit: www.gebuwin.com

Technical specifications SD125-500

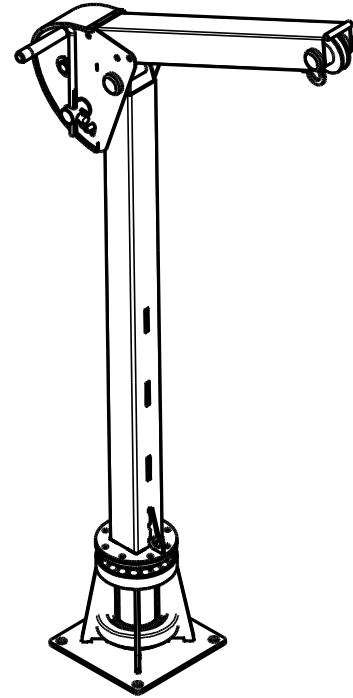
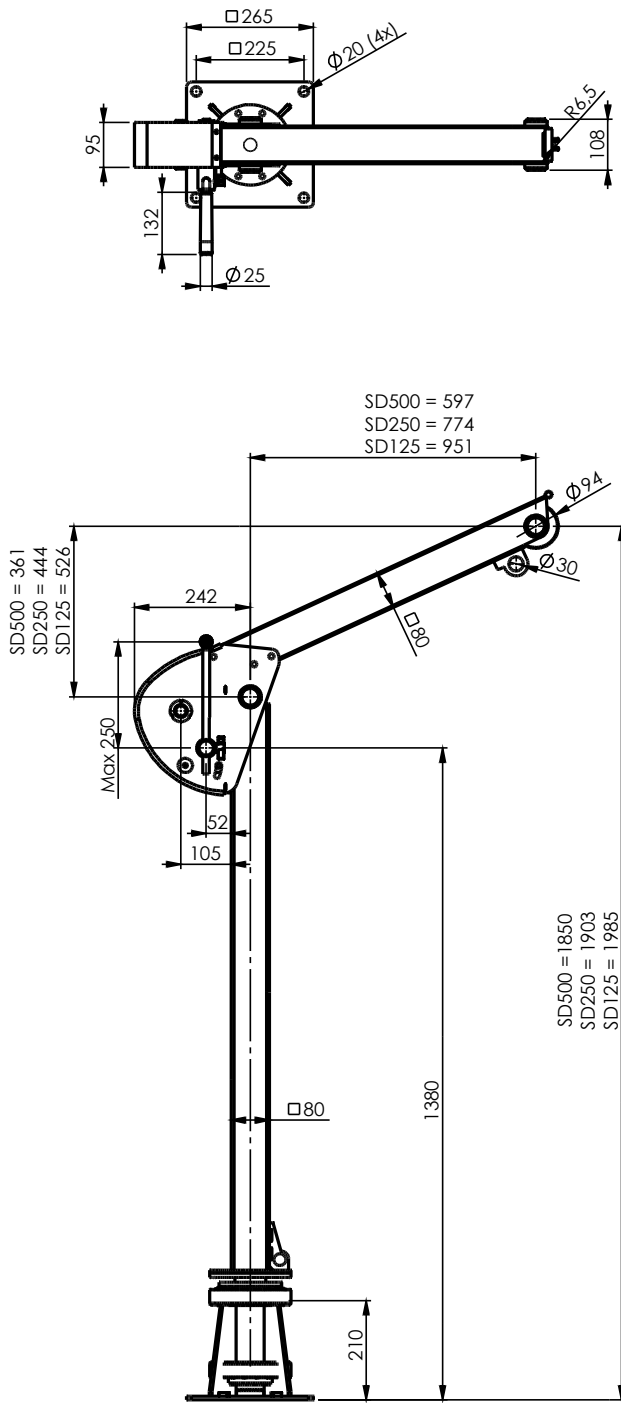

Technical specifications	Unit	SD125	SD250	SD500
Reach	cm	951	774	597
Capacity 1st layer	kg	125	250	500
Capacity top layer	kg	125	250	500
Max. rope storage top layer*	m	18	18	13
Lifting speed	m/min	1,2	1,2	1,2
Crank effort at full load	kg	6	8	10
Weight Swivel Davit	kg	30	30	30
Weight floor-socket	kg	8,9	8,9	8,9
Article number	no.	77001940	77001930	77001920
*standard delivered with 13m cable				

Swivel Davit Crane

300 – 500 kg

Description of the winch

This davit crane is specifically designed to meet the needs of water treatment plants. Unlike other models with integrated winches, the winch is situated on top of the davit. This placement allows for a cable to be securely attached to a pump. Additionally, this davit is compatible with the Pulley Man, which means that lifting heavy loads of up to 300 kg requires no manual effort, making operations significantly easier and more efficient.

Product specifications

- robust and safe lifting davit crane in compliance with EN13157
- ready to use in 5 seconds
- easy to transport
- Suitable to use with a manual winch or Pulley Man
- possible to rotate 360° due to the use of ball bearings
- zinc plated finish



Options (code)

- ATEX certified zone 2 and 22 (EX)
 - CE II 3G Ex IIC T4 Gc, -20°C<T amb <+70°C
 - CE II 3D Ex IIIC T135°C Dc, -20°C<T amb <+70°C
- custom options possible - [on request](#)

Accessoires

- floor, wall and in-concrete sockets
- carry bag and protection cover

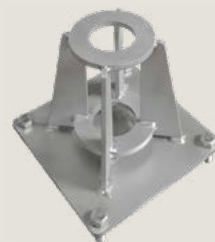

CE Ex  [Product & instruction video on YouTube](#)

Technical specifications SD501

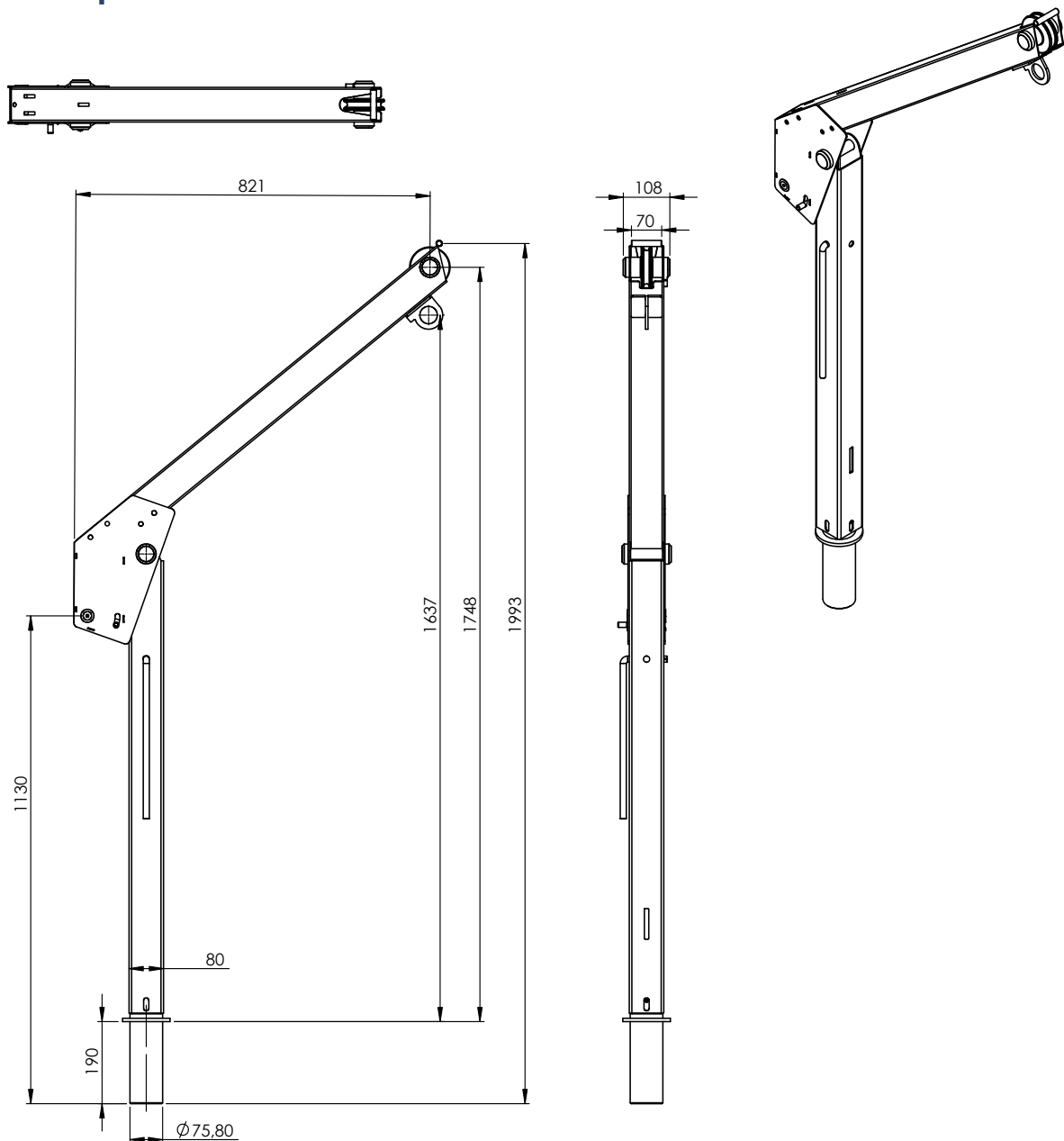

Technical specifications	Unit	SD501
Reach	cm	821
Capacity 1st layer - winch	kg	500
Capacity top layer - winch	kg	500
Capacity 1st layer - PM300	kg	300
Capacity top layer - PM300	kg	300
Max. rope storage top layer - winch	m	13
Max. rope storage top layer - PM300	m	120
Lifting speed - winch	m/min	1,2
Lifting speed - PM300	m/min	4
Crank effort at full load - winch	kg	10
Weight Swivel Davit	kg	24
Weight Swivel Davit incl. PM300	kg	29
Weight Swivel Davit incl. winch	kg	35
Weight floor-socket	kg	8,9
Article number - SD501 + winch	no.	77001910
Article number - SD501 + PM300	no.	77001916

Will follow soon!

400 kg

Description of the winch

This davit has a maximum reach of 2 metres with a lifting force of 400 kg. The davit has 4 different positions with which the reach can be adjusted.

Product specifications

- robust and safe lifting davit crane in compliance with EN13157
-

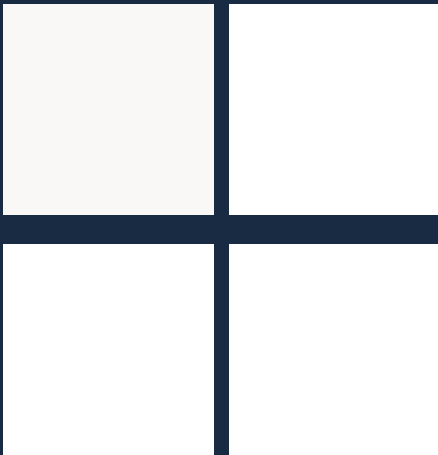

Options (code)

- Height adjustable
- ATEX certified zone 2 and 22 (EX)
 - CE II 3G Ex IIC T4 Gc, -20°C<T amb <+70°C
 - CE II 3D Ex IIIC T135°C Dc, -20°C<T amb <+70°C
- custom options possible - [on request](#)

Accessoires

- floor, wall and in-concrete sockets

CE Ex  [Product & instruction video on YouTube](#)

Technical specifications SD

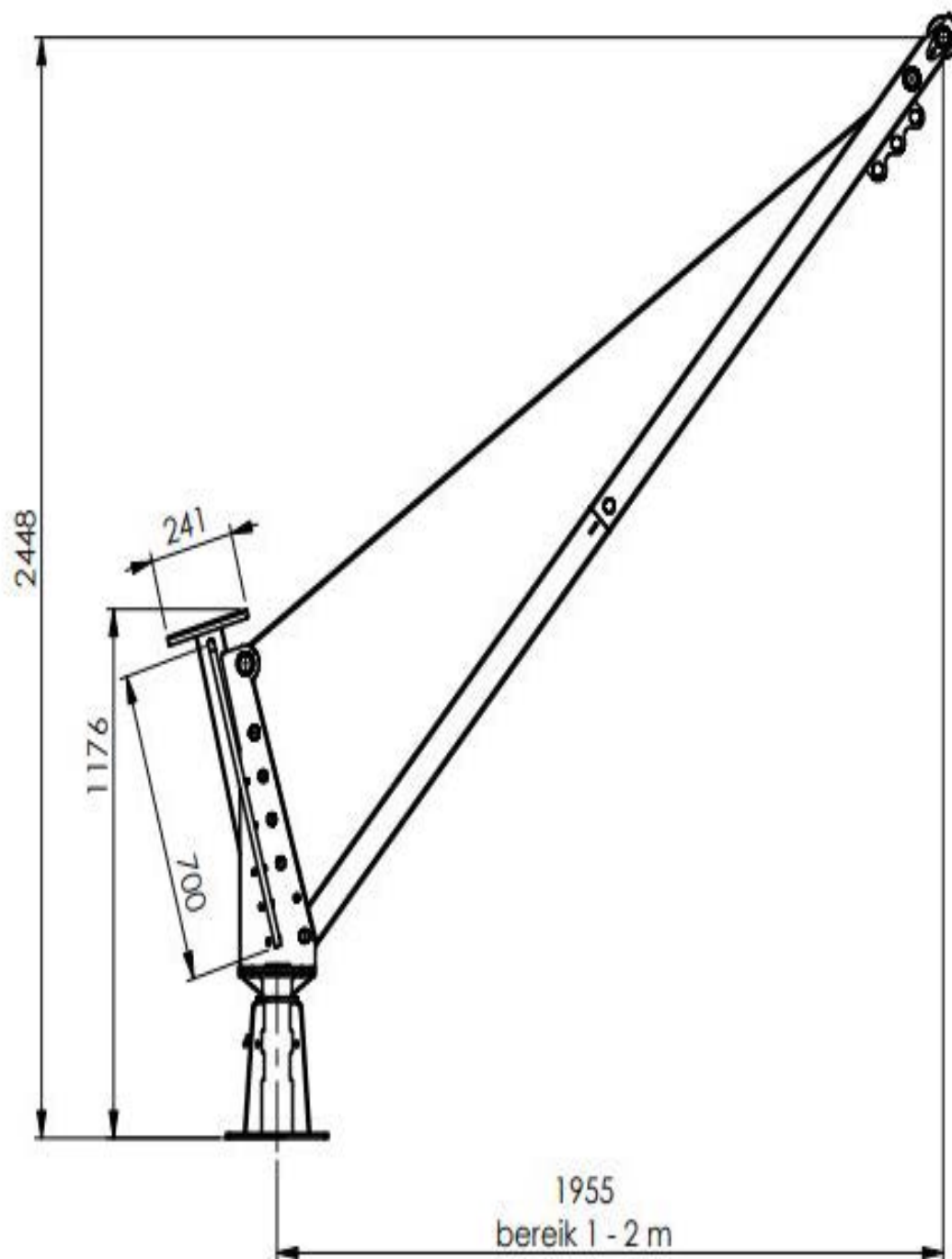

Technical specifications	Unit	SD
Capacity 1st layer	kg	
Capacity top layer	kg	
Max. rope storage top layer*	m	
MBL of cable	kN	
Lifting speed	m/min	
Crank effort at full load	kg	
Weight Swivel Davit	kg	
Weight floor-socket	kg	
Article number	no.	

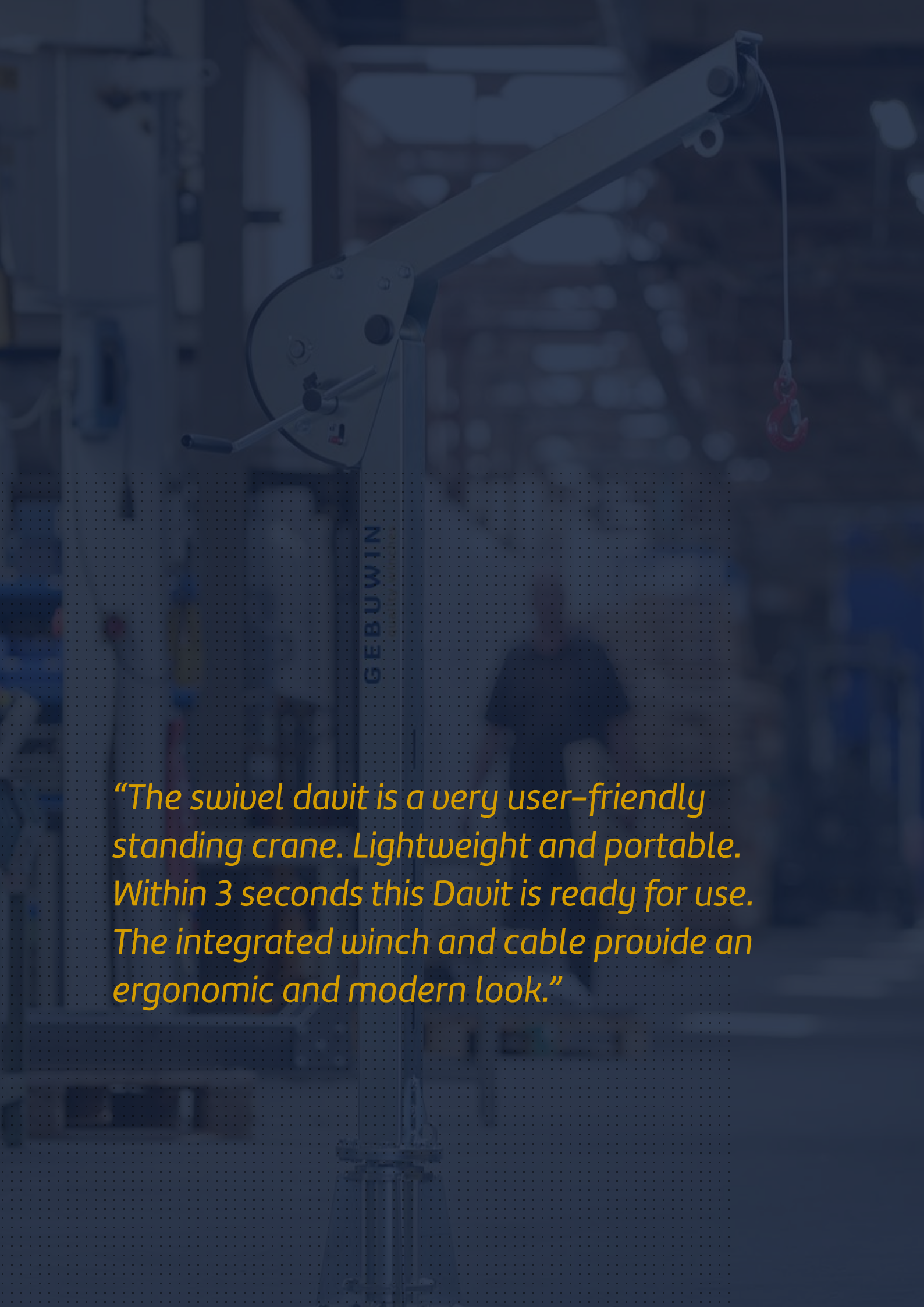

“The swivel davit is a very user-friendly standing crane. Lightweight and portable. Within 3 seconds this Davit is ready for use. The integrated winch and cable provide an ergonomic and modern look.”

Accessories

In order to move a load, a cable is required in addition to a winch. Pulley blocks are used to position the cable correctly in relation to the load. Gebuwin has the right cable and pulley blocks for every winch and application. Gebuwin also has hand winches that can be operated with an air or electric motor. These can be found on the following pages.



Index

- Wire rope cables p. 57
- Pulley blocks SST p. 61
- Pulley blocks p. 59
- Power tools AM-EM p. 63

Ropes

Galvanised, stainless steel and fiber

Description

Gebuwin supplies cables in a galvanized and a stainless steel version in various lengths and thicknesses. We also supply fiber ropes which are unique in strength and weight. A common application is with hook or eye.

All ropes are in compliance with EN12385 and EN13157.

If you want to know which cable is applicable to you, ask Gebuwin.

We like to advise you.

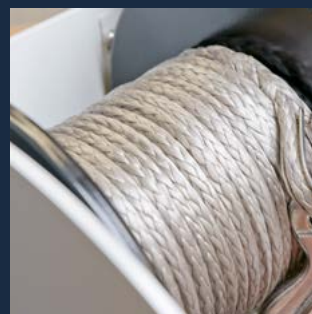

Technical specifications galvanised wire rope

Diameter Ø	Construction	MBL kN	MBL KG	WLL
4	19x7	10	1020	314
5	19x7	17	1734	510
6	19x7	23	2345	706
8	19x7	41	4181	1254
10	19x7	70	7138	2136
12	19x7	100	10197	3060
14	35x7	137	13970	4200
16	35x7	180	18355	5490
18	35x7	226	23046	6900
22	35x7	338	34466	10350

Technical specifications stainless steel wire rope

Diameter Ø	Construction	MBL kN	MBL KG	WLL
4	7x19	8	816	255
5	7x19	13	1326	415
6	7x19	19	1937	576
8	7x19	33,5	3416	1023
10	7x19	52	5303	1593
12	6x36	75	7648	2298
14	6x36	102	10401	3030
16	6x36	133	13562	3850
18	6x36	181	18457	5550

Technical specifications Dyneema fiber rope

Diameter Ø	Construction	MBL kN	MBL kg	WLL
4	12 strand braided	14	1428	300
5	12 strand braided	24	2447	520
6	12 strand braided	32	3263	650
8	12 strand braided	56	5710	1100
10	12 strand braided	80	8158	1600
12	12 strand braided	119	12135	2430
14	12 strand braided	167	17029	3400
16	12 strand braided	191	19477	3900
18	12 strand braided	243	24779	4950
20	12 strand braided	308	31407	6250
24	12 strand braided	437	44562	8900

Pulley block

Painted

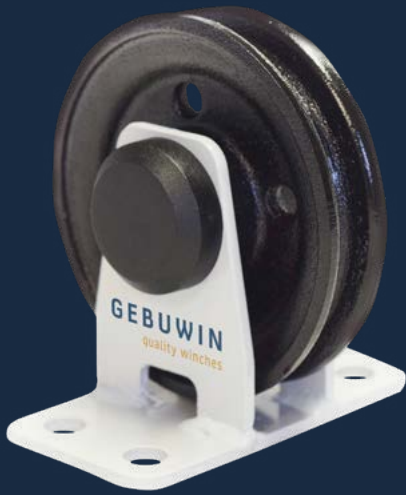

Description

The pulley blocks from Gebuwin's product range are suitable for both hand and electric winches. The wheel is manufactured from cast iron and fitted with bearings. The pulley blocks are used to guide the cable to the location where the load has to be moved. A fine way to make moving your load easier.

Product specifications

- suitable for electric and manual winches
- pulley wheel made of cast iron
- bracket made of steel with one layer of paint
- plain bearing

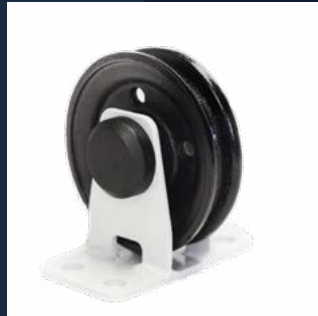

Options (code)

- ATEX suitable

Technical specifications KB150-7500

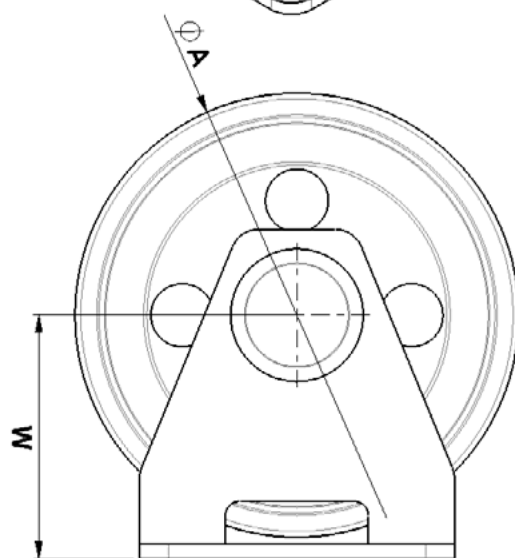
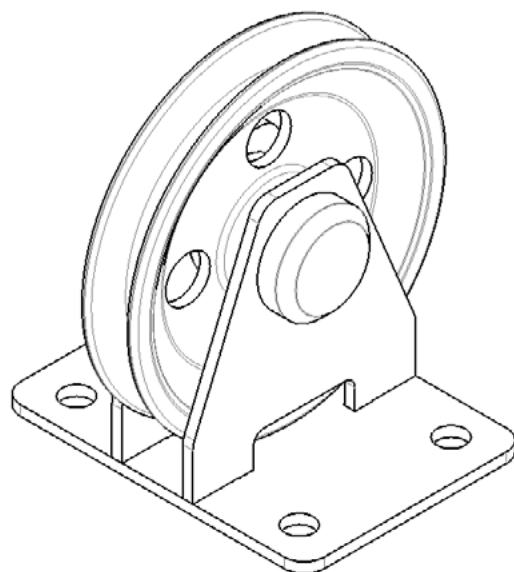
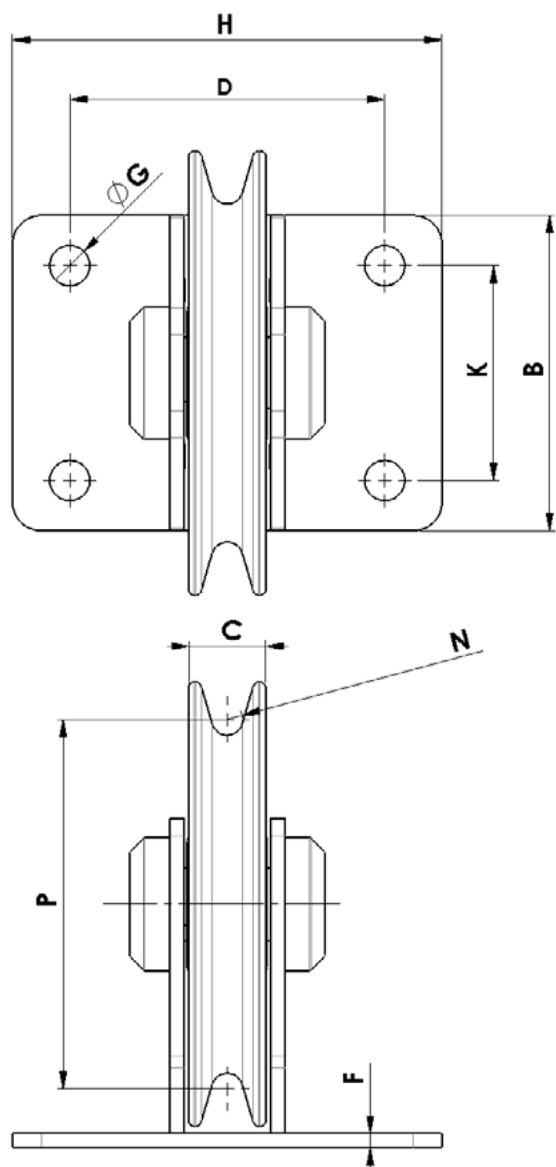

Dimensions (mm)	A	B	C	D	E	G	H	K	M	N	P
<u>KB150</u>	90	60	18	65	5	11	90	35	54	4,5	72
<u>KB300</u>	100	65	20	70	5	11	100	35	59	5	80
<u>KB600</u>	120	65	28	75	5	13	105	35	69	5,5	98
<u>KB1500</u>	155	110	27	80	6	14	120	75	85	5,5	129
<u>KB2000</u>	220	165	32	105	8	17	155	115	121	8,5	184
<u>KB4000</u>	260	200	40	140	10	21	195	145	143	9,5	222
<u>KB7500</u>	310	240	52	155	12	21	215	180	170	14	250

Technical specifications	Unit	<u>KB150</u>	<u>KB300</u>	<u>KB600</u>	<u>KB1500</u>	<u>KB2000</u>	<u>KB4000</u>	<u>KB7500</u>
Max. capacity	kg	150	300	600	1500	2000	4000	7500
Max. rope diameter-Ø	mm	8	9	10	10	16	18	26
Weight	kg	1	1	1,5	3	6,5	11,5	21
Article number	no.	77001760	77001750	77001700	77001710	77001720	77001730	77001740

Pulley block

Stainless steel 316

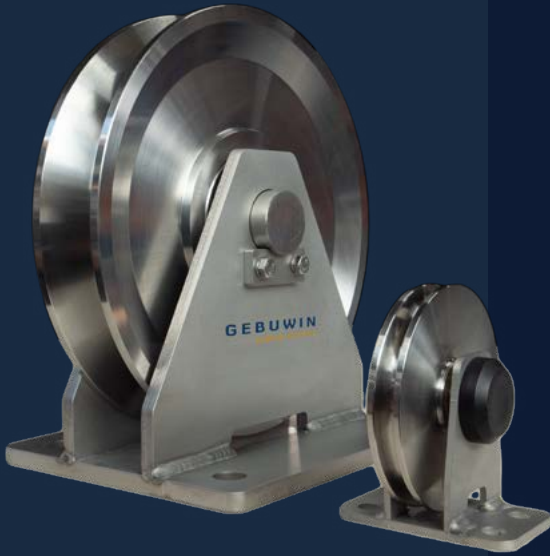

Description

The stainless steel pulley blocks from Gebuwin's product range are suitable for both hand and electric winches. The wheel and frame are made of stainless steel 316 and fitted with bearings.

The pulley blocks are used to guide the cable to the location where the load has to be moved. A fine way to make moving your load easier.

Product specifications

- suitable for electric and manual winches
- pulley wheel made of stainless steel 316
- bracket made of stainless steel 316
- plain bearing

Options (code)

- ATEX suitable

Technical specifications KB150-7500

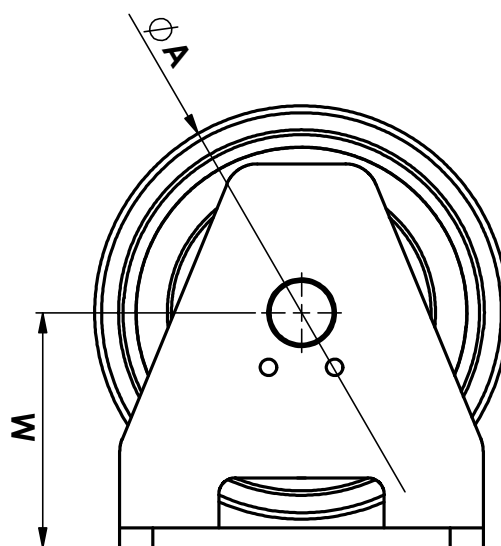
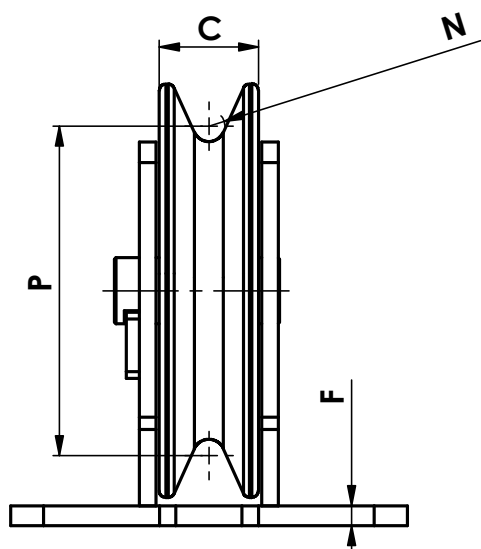
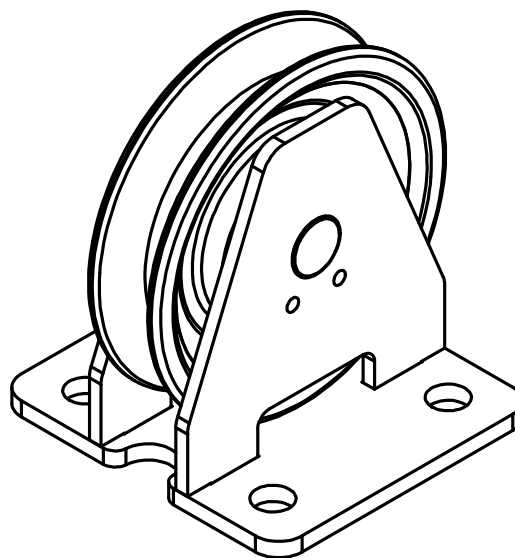
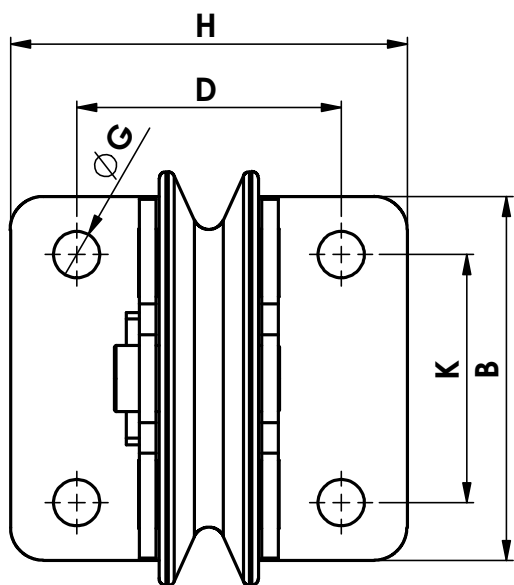

Dimensions (mm)	A	B	C	D	E	G	H	K	M	N	P
<u>KB150 (304)</u>	75	60	18	65	5	11	90	35	48	4,2	67
<u>KB300 (304)</u>	100	65	21	70	5	11	100	35	60	4,8	90
<u>KB500</u>	85	60	21	65	5	11	90	35	53	3,2	66
<u>KB1000</u>	125	110	30	80	6	14	120	75	71	4,8	139
<u>KB2000</u>	180	165	38	105	8	17	155	115	103	7	149
<u>KB4000</u>	240	200	50	140	10	21	195	145	135	9,5	204
<u>KB6500</u>	300	240	60	155	12	21	215	180	167	12,5	255

Technical specifications	Unit	<u>KB150_SST</u>	<u>KB300_SST</u>	<u>KB500_SST</u>	<u>KB1000_SST</u>	<u>KB2000_SST</u>	<u>KB4000_SST</u>	<u>KB6500_SST</u>
Max. capacity	kg	150	300	500	1000	2000	4000	6500
Max. rope diameter-Ø	mm	8	9	10	10	16	18	26
Weight	kg	1	1	1,5	3	6,5	11,5	21

Power tools

Electric and air power tools

Description

The AM and EM 5000 power tools are very effective alternatives to manual power. Moving heavy loads will go three times faster than manually operating the winch. The AM5000 power tool is powered by air and so it can be ATEX certified. The EM5000 power tool has an electrical motor with 230V.

The power tools are an alternative to the manual drive and are only used for short and non-frequent applications. The combination of a hand winch and these power tools are not an alternative to an electric winch.



Product specifications AM5000

- air motor is equipped with a filter and hose fitting
- painted air motor and zinc plated adapter system
- ATEX certified (EX)

Product specifications EM5000

- electric drill motor 230V-50Hz
- including zinc plated winch adapter, additional handle, drift key and suspension eyelet

CE   [Product & instruction video on YouTube](#)



Technical specifications	Unit	AM5000	EM5000
Power	W	1200	1800
Air pressure	bar	Max. 6	-
Voltage - frequency	-	-	230V-50Hz
Variable speed at max. power	rpm	60	60 - 140
Dimension L x H x B mm	mm	545 x 76 x 277	510 x 530 x 150
Own weight (excl. cable)	kg	5	10
Air consumption at max power	l/min	2100	-
Min. fitting / hose diameter (inside)	mm	10,4 / 15	-
Cable length with plug	m	-	2,5
Article number	no.	77001600	77001620

Terms and Conditions of the Metaalunie

1 January 2019

General Terms and Conditions issued by Koninklijke Metaalunie (the employers' organisation for small and medium-sized enterprises in the metal industry) referred to as TERMS AND CONDITIONS OF THE METAALUNIE, filed with the Registry of the Court of Rotterdam on 1 January 2019.
Publication of the Koninklijke Metaalunie, P.O. Box 2600, 3430 GA, Nieuwegein.

© Koninklijke Metaalunie

Article 1: Scope of application

- 1.1. These Terms and Conditions apply to all offers made by a Metaalunie member, to all agreements that it enters into and to all agreements arising from this, all of which insofar as the Metaalunie member is the supplier or the contractor.
- 1.2. Metaalunie members who apply these Terms and Conditions are referred to as the Contractor. The other party is referred to as the Client.
- 1.3. In the event of conflicts between the agreement entered into by the Client and the Contractor and these Terms and Conditions, the provisions of the agreement will prevail.
- 1.4. These Terms and Conditions may only be applied by Metaalunie members.

Article 2: Offers

- 2.1. All offers are without obligation. The Contractor is entitled to revoke its offer up to two working days after it has received the acceptance.
- 2.2. If the Client provides the Contractor with information, the Contractor may assume that it is accurate and complete and will base its offer on this information.
- 2.3. The prices stated in the offer are denominated in euros, excluding VAT and other government levies or taxes. The prices do not include travel, accommodation, packaging, storage and transport costs, nor do they include costs for loading, unloading and cooperating with customs formalities.

Article 3: Confidentiality

- 3.1. All information provided to the Client by or on behalf of the Contractor, such as offers, designs, images, drawings and know-how, of whatever nature and in whatever form are confidential, and the Client will not use it for any purpose other than for the implementation of the agreement.
- 3.2. The Client will not disclose or reproduce the information referred to in paragraph 1 of this article.
- 3.3. If the Client infringes one of the obligations referred to in paragraphs 1 and 2 of this article, it will owe an immediately payable penalty of € 25,000 for each infringement. This penalty can be claimed in addition to compensation by virtue of the law.
- 3.4. The Client must return or destroy the information referred to in paragraph 1 of this article immediately on request, within a period set at the discretion of the Contractor. If this provision is infringed, the Client will owe the Contractor an immediately payable penalty of € 1,000 per day. This penalty can be claimed in addition to compensation by virtue of the law.

Article 4: Advice and information provided

- 4.1. The Client cannot derive any rights from advice and information provided by the Contractor that is not directly related to the contract.
- 4.2. If the Client provides the Contractor with information, the Contractor may assume that it is accurate and complete when implementing the agreement.
- 4.3. The Client indemnifies the Contractor against any third-party claims related to the use of advice, drawings, calculations, designs, materials, brands, samples, models and the like provided by or on behalf of the Client. The Client will compensate the Contractor for all damage suffered by the Contractor, including all costs incurred for defence against these claims.

Article 5: Delivery time/implementation period

- 5.1. Delivery times or implementation periods specified are indicative.
- 5.2. The delivery time or implementation period only commences once an agreement has been reached on all commercial and technical details, once all the information, including final and approved drawings and the like, is in the possession of the Contractor, the agreed payment (or instalment) has been received, and the other conditions for the contract have been met.
- 5.3. If:
 - a. there are circumstances other than those known to the Contractor at the time it set the delivery period or implementation period, the delivery period or implementation period may be extended by the time the Contractor needs – taking into account its planning – to implement the contract under these circumstances;
 - b. there are contract extras, the delivery period or implementation period may be extended by the time the Contractor needs – taking into account its planning – to have the materials and parts delivered and to carry out the contract extras;
 - c. the Contractor suspends its obligations, the delivery period or implementation period may be extended by the time the Contractor needs – taking into account its planning – to implement the contract after the reason for the suspension no longer applies.

Unless the Client has evidence to the contrary, the duration of the extension of the delivery period or implementation period is presumed to be necessary and to be the result of a situation as referred to above in a to c.

- 5.4. The Client is obliged to pay all costs that the Contractor incurs or damages that the Contractor suffers as a result of a delay in the delivery or implementation period as stated in paragraph 3 of this article.
- 5.5. Under no circumstances does exceeding the agreed delivery or implementation period give the Client the right to compensation or to terminate the agreement. The Client indemnifies the Contractor against any third-party claims due to exceeding the delivery or implementation period.

Article 6: Delivery and risk transfer

- 6.1. Delivery takes place when the Contractor, at its business location, makes the good available to the Client and has informed the Client that the good is at its disposal. From that time onwards, the Client bears the risk of the good in terms of storage, loading, transport and unloading among others.
- 6.2. The Client and the Contractor may agree that the Contractor will be responsible for the transport. In that case too, the Client bears the risk of, inter alia, storage, loading, transport and unloading. The Client can insure itself against these risks.
- 6.3. If a good is exchanged and the Client retains the good to be exchanged pending delivery of the new good, the risk of the good to be exchanged remains with the Client until the time that it hands over the good to the Contractor. If the Client is unable to deliver the good to be exchanged in the condition in which it was when the agreement was concluded, the Contractor may terminate the agreement.

Article 7: Price changes

The Contractor may pass on to the Client an increase in cost-determining factors that occurs after entering into the agreement. The Client is obliged to pay the price increase immediately on the Contractor's request.

Article 8: Force majeure

- 8.1. If the Contractor fails to fulfil its obligations, this cannot be attributed to the Contractor if this failure is due to force majeure.
- 8.2. Force majeure includes, inter alia, if third parties engaged by the Contractor – such as suppliers, subcontractors and transporters, or other parties that the Client is dependent on – do not meet their obligations at all or on time, or circumstances due to weather conditions, natural disasters, terrorism, cyber-crime, disruption of digital infrastructure, fire, power failures, loss, theft or loss of tools, materials or information, roadblocks, strikes or work interruptions and import or trade restrictions.
- 8.3. The Contractor is entitled to suspend fulfilment of its obligations if it is temporarily prevented from fulfilling its obligations to the Client due to force majeure. Once the force majeure circumstances no longer apply, the Contractor will fulfil its obligations as soon as its planning permits.
- 8.4. If it concerns force majeure and fulfilment is or becomes permanently impossible, or the temporary force majeure circumstances have lasted for more than six months, the Contractor is entitled to terminate the agreement with immediate effect either entirely or in part. In those cases, the Client is entitled to terminate the agreement with immediate effect, but only for that part of the obligations that the Contractor has not yet fulfilled.
- 8.5. The parties are not entitled to compensation for the damages suffered or to be suffered as a result of the force majeure, suspension or termination as referred to in this article.

Article 9: Scope of the work

- 9.1. The Client must ensure that all licences, exemptions and other decisions that are necessary to carry out the work are obtained in good time. The Client is obliged to send the Contractor a copy of the aforementioned documents immediately on the Contractor's request.
- 9.2. Unless otherwise agreed in writing, the work does not include:
 - a. groundwork, pile driving, cutting, breaking, foundation work, masonry, carpentry, plastering, painting, wallpapering, repair work or other construction work;
 - b. making connections to gas, water, electricity, internet or other infrastructural facilities;
 - c. measures to prevent or limit damage to, of theft or loss of goods present at or near the workplace;

- d. removing equipment, building materials or waste;
- e. vertical and horizontal transport.

Article 10: Contract extras

- 10.1. Changes in the work will in any event lead to contract extras if:
 - a. it concerns changes in the design, the specifications or the contract documents;
 - b. the information provided by the Client does not correspond with reality;
 - c. the estimated quantities deviate by more than 5%.
- 10.2. Contract extras are calculated on the basis of the price-determining factors that apply at the time the extra work is performed. The Client is obliged to pay the price for the contract extras immediately on the Contractor's request.

Article 11: Implementation of the work

- 11.1. The Client will ensure that the Contractor can carry out its work undisturbed and at the agreed time and that it is given the necessary facilities for the implementation of its work, such as:
 - a. gas, water, electricity and internet;
 - b. heating;
 - c. lockable dry storage space;
 - d. the facilities prescribed under the Dutch Working Conditions Act [Arbowet].
- 11.2. The Client bears the risk and is liable for damage to and theft or loss of goods belonging to the Contractor, Client and third parties, such as tools, material or equipment intended for the work or used for the work, located at or near the place where the work is carried out or at another agreed location.
- 11.3. Notwithstanding the provisions in paragraph 2 of this article, the Client is obliged to take out adequate insurance against the risks referred to in that paragraph. In addition, the Client must take out insurance for the risk of work-related damage with regard to the equipment to be used. The Client must send the Contractor a copy of the relevant insurance(s) and proof of payment of the premium immediately on request. In the event of damages, the Client is obliged to report this immediately to its insurer for further processing and settlement.

Article 12: Delivery of the work

- 12.1. The work is considered to be delivered in the following cases:
 - a. once the Client has approved the work;
 - b. if the Client has put the work into operation. If the Client puts part of the work into operation, then that part is considered to have been delivered;
 - c. if the Contractor has notified the Client in writing that the work has been completed, and the Client fails to inform the Contractor in writing that the work has not been approved within 14 days of the day of the notification;
 - d. if the Client does not approve the work on the grounds of minor defects or missing parts that can be repaired or delivered within 30 days and that do not hinder the commissioning of the work.
- 12.2. If the Client does not approve the work, it is obliged to inform the Contractor of this in writing, stating the reasons. The Client must give the Contractor the opportunity to deliver the work at a later date.
- 12.3. The Client indemnifies the Contractor against third-party claims concerning damage to parts of the work not delivered due to the use of parts of the work that have already been delivered.

Article 13: Liability

- 13.1. In the event of an attributable failure, the Contractor is still obliged to fulfil its contractual obligations, with due observance of Article 14.
- 13.2. The Contractor's obligation to compensate damages – regardless of the grounds – is limited to the damage against which the Contractor is covered

under an insurance policy taken out by it or on its behalf. However, the scope of this obligation is never greater than the amount paid out under this insurance in the case in question.

- 13.3. If, for whatever reason, the Contractor does not have the right to invoke paragraph 2 of this article, the obligation to compensate damage is limited to a maximum of 15% of the total contract amount (excluding VAT). If the agreement consists of parts or partial deliveries, this obligation is limited to a maximum of 15% (excluding VAT) of the contract amount for that part or that partial delivery. If it concerns continuing performance contracts, the obligation to compensate damage is limited to a maximum of 15% (excluding VAT) of the contract amount owed over the last twelve months prior to the loss-causing event.
- 13.4. The following do not qualify for compensation:
- consequential damages. Consequential damages include inter alia business interruption losses, loss of production, loss of profit, penalties, transport costs and travel and subsistence expenses;
 - damage to property in the care, custody or control of, but not owned by the insured party. Among other things, this damage includes damage caused by or during the performance of the work to goods that are being worked on or to goods that are located in the vicinity of the place where the work is being carried out;
 - damage as a result of intent or wilful recklessness by the Contractor's auxiliary staff or non-managerial subordinates.

The Client can take out insurance for these damages if possible.

- 13.5. The Contractor is not obliged to compensate damage to material supplied by or on behalf of the Client as a result of improper processing.
- 13.6. The Client indemnifies the Contractor against all third-party claims due to product liability as a result of a defect in a product that has been delivered by the Client to a third party and of which the products or materials supplied by the Contractor are a part. The Client is obliged to reimburse all the damages suffered by the Contractor in this respect, including the (full) costs of the defence.

Article 14: Guarantee and other claims

- 14.1. Unless otherwise agreed in writing, the Contractor guarantees the proper execution of the agreed performance for a period of six months after delivery or completion, as detailed in the following paragraphs.
- 14.2. If the parties have agreed to deviating guarantee conditions, the provisions of this article will remain in full force, unless this is in conflict with those deviating guarantee conditions.
- 14.3. If the agreed performance has not been executed properly, the Contractor will decide within a reasonable period of time whether it will still perform the work properly or credit the Client for a proportionate part of the contract amount.
- 14.4. If the Contractor opts to still execute the performance properly, it will determine the manner and time of execution. The Client must in all cases offer the Contractor the opportunity to do so. If the agreed performance (also) included the processing of material provided by the Client, the Client must supply new material at its own expense and risk.
- 14.5. The Client is responsible for sending parts or materials that are to be repaired or replaced by the Contractor to the Contractor's business location.
- 14.6. The following are for the Client's account:
- all transport or shipping costs;
 - costs for dismantling and assembly;
 - travel and subsistence expenses and travel time.
- 14.7. The Contractor is only obliged to implement the guarantee if the Client has fulfilled all its obligations.
- 14.8. a. The guarantee does not cover defects that are the result of:
- normal wear and tear;

- improper use;
 - lack of maintenance or maintenance carried out incorrectly;
 - installation, assembly, modification or repairs carried out by the Client or third parties;
 - faulty or unsuitable goods originating from or prescribed by the Client;
 - faulty or unsuitable materials or tools used by the Client.
- b. No guarantee is given for:
- goods delivered that were not new at the time of delivery;
 - inspections and repairs carried out on goods owned by the Client;
 - parts that are subject to a manufacturer's guarantee.

- 14.9. The provisions of paragraphs 3 to 8 of this article apply by analogy to any of the Client's claims based on breach of contract, non-conformity or any other basis whatsoever.

Article 15: Obligation to complain

- 15.1. The Client no longer has the right to invoke a defective performance if it has not complained to the Contractor in writing within fourteen days after it discovered or should reasonably have discovered the defect.
- 15.2. The Client must have filed complaints about the invoice with the Contractor in writing and within the payment term, subject to forfeiture of all rights. If the payment term is longer than thirty days, the Client must have filed its complaint in writing within thirty days of the invoice date at the latest.

Article 16: Failure to take possession of goods

- 16.1. The Client is obliged to take actual possession of the goods that are the subject of the agreement at the agreed location at the end of the delivery or implementation period.
- 16.2. The Client must cooperate fully and free of charge to enable the Contractor to deliver the goods.
- 16.3. Goods not taken into possession are stored at the Client's expense and risk.
- 16.4. If the provisions of paragraph 1 or 2 of this article are infringed, the Client will owe the Contractor a penalty for each infringement of € 250 per day up to a maximum of € 25,000, after the Contractor has given notice of default. This penalty can be claimed in addition to compensation by virtue of the law.

Article 17: Payment

- 17.1. Payment is made at the Contractor's business address or into an account to be designated by the Contractor.
- 17.2. Unless otherwise agreed, payments must be made within 30 days of the invoice date.
- 17.3. If the Client fails to fulfil its payment obligation, it is obliged to comply with a request from the Contractor for a tender of payment instead of the agreed amount.
- 17.4. The Client's right to offset its claims against the Contractor or to suspend the fulfilment of its obligations is excluded, unless the Contractor has been granted a suspension of payments or is bankrupt or the statutory debt adjustment scheme applies to the Contractor.
- 17.5. Irrespective of whether the Contractor has fully executed the agreed performance, everything that the Client owes or will owe it under the agreement is immediately due and payable if:
- a payment term has been exceeded;
 - the Client does not fulfil its obligations under Article 16;
 - the Client has filed for bankruptcy or suspension of payments;
 - the Client's goods or claims have been attached;

- e. the Client (a company) is dissolved or wound up;
- f. the Client (a natural person) files a application to be admitted to the statutory debt adjustment scheme, is placed under a guardianship order or has died.

17.6. If payment is delayed, the Client will owe interest on that sum to the Contractor with effect from the day following the day agreed as the final day of payment up to and including the day on which the Client settles the amount in question. If the parties have not agreed on the final day of payment, the interest is due from 30 days after the sum has become due and payable. The interest is 12% per year, but is equal to the statutory interest if this is higher. For the interest calculation, a part of the month is considered to be a full month. At the end of each year, the amount on which the interest is calculated will be increased by the interest due for that year.

17.7. The Contractor is entitled to offset its debts to the Client against claims that companies affiliated to the Contractor have against the Client. In addition, the Contractor is entitled to offset its claims to the Client against debts that companies affiliated to the Contractor have against the Client. Furthermore, the Contractor is entitled to offset its debts to the Client against claims against companies affiliated to the Client. 'Affiliated companies' means all companies belonging to the same group, within the meaning of Book 2, Section 24b of the Dutch Civil Code, and a participation within the meaning of Book 2, Section 24c of the Dutch Civil Code.

17.8. For late payments, the Client owes the Contractor all extrajudicial costs with a minimum of € 75.

These costs are calculated on the basis of the following table, i.e., the principal sum plus interest:

on the first	€ 3,000	15%
on the excess up to	€ 6,000	10%
on the excess up to	€ 15,000	8%
on the excess up to	€ 60,000	5%
on the excess from	€ 60,000 or more	3%

The extrajudicial costs actually incurred are due if they are higher than the calculation given above.

17.9. If judgment is rendered in favour of the Contractor in legal proceedings, either entirely or for the most part, the Client will bear all costs incurred in connection with these proceedings.

Article 18: Securities

18.1. Irrespective of the agreed payment terms, the Client is obliged to provide sufficient security for payment immediately on the Contractor's request and at its discretion. If the Client does not comply with this provision within the set time limit, it will immediately be in default. In that case, the Contractor has the right to terminate the agreement and to recover its damages from the Client.

18.2. The Contractor remains the owner of the delivered goods as long as the Client:

- a. has not fulfilled its obligations under any agreement with the Contractor;
- b. claims arising from non-fulfilment of the aforementioned agreements, such as damage, penalties, interest and costs, have not been settled.

18.3. As long as the delivered goods are subject to retention of title, the Client may not encumber or dispose of these goods other than in the course of its normal business operations. This provision has effect under property law.

18.4. After the Contractor has invoked its retention of title, it may take back the delivered goods. The Client will cooperate fully with this.

18.5. If the Client has fulfilled its obligations after the Contractor has delivered the goods to it in accordance with the agreement, the retention of title with re-

spect to these goods is revived if the Client does not fulfil its obligations under an agreement entered into subsequently.

18.6. The Contractor has a right of pledge and a right of retention on all goods that it has or may receive from the Client on any grounds whatsoever and for all claims that it has or might have against the Client.

Article 19: Intellectual property rights

19.1. The Contractor is considered to be the maker, designer or inventor of the works, models or inventions created in the context of the agreement. The Contractor therefore has the exclusive right to apply for a patent, trademark or model.

19.2. The Contractor will not transfer any intellectual property rights to the Client in the implementation of the agreement.

19.3. If the performance to be delivered by the Contractor (also) includes providing computer software, the source code will not be handed over to the Client. The Client will only acquire a non-exclusive, worldwide and perpetual licence for use for the computer software solely for the purpose of the normal use and proper functioning of the good. The Client is not permitted to transfer the licence or to issue a sub-licence. When the Client sells the good to a third party, the licence transfers by operation of law to the acquirer of the good.

19.4. The Contractor disclaims liability for damages that the Client suffers as a result of an infringement of third-party intellectual property rights. The Client indemnifies the Contractor against any third-party claims related to an infringement of intellectual property rights.

Article 20: Assignment of rights or obligations

The Client may not assign or pledge any rights or obligations pursuant to any article in these General Terms and Conditions or the underlying agreement(s), unless it has the prior written consent of the Contractor. This provision has effect under property law.

Article 21: Cancellation or termination of the agreement

21.1. The Client is not entitled to cancel or terminate the agreement, unless the Contractor agrees to this. If the Contractor agrees, the Client will owe the Contractor an immediately due and payable compensation equal to the agreed price, less the savings for the Contractor as a result of the termination. The compensation will be at least 20% of the agreed price.

21.2. If the price depends on the actual costs to be incurred by the Contractor (on a cost-plus basis), the compensation as referred to in the first paragraph of this article is estimated based on the sum of the costs and labour and the profit that the Contractor would have made for the entire contract.

Article 22: Applicable law and competent court

22.1. Dutch law applies.

22.2. The Vienna Sales Convention (CISG) does not apply, nor does any other international regulation that may be excluded.

22.3. The Dutch civil court with jurisdiction in the Contractor's place of business is authorised to take cognisance of any disputes. The Contractor may deviate from this rule governing jurisdiction and rely on the statutory rules governing jurisdiction instead.

These Terms and Conditions constitute a comprehensive translation of the Dutch version of the Terms and Conditions of the Metaalunie as filed with the Registry of the Court of Rotterdam on 1 January 2019. The Dutch version will prevail in the explanation and interpretation of this text.

GEBUWIN

quality winches

GEBUWIN
quality winches

Gebuwin B.V.

Industrieweg 6
7102 DZ Winterswijk
The Netherlands

+31 (0)543 532600
info@gebuwin.com
www.gebuwin.com